

Whirlamatic™ 17/20UHS

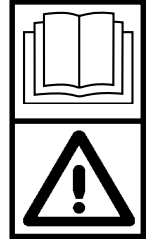

OPERATOR MANUAL

**Advance MODELS 56183100, 56183105(OBS)
56183700, 56183701(OBS), 56183705**



**Nilfisk
Advance**

setting standards

revised 4/01 FORM NO. 56041233

TABLE OF CONTENTS

	PAGE
INTRODUCTION	2
IMPORTANT SAFETY INSTRUCTIONS	3
IMPORTANT SAFETY INSTRUCTIONS	4
GROUNDING INSTRUCTIONS	5
PREPARING THE FLOOR	6
PREPARING THE MACHINE FOR USE	6
OPERATING CONTROLS	7
OPERATING THE MACHINE	8
AFTER USING MACHINE	8
MAINTENANCE	9
TROUBLESHOOTING	10

INTRODUCTION

This manual will help you get the most from your **Advance Whirlamatic**. Read it thoroughly before operating the machine. References to “right” and “left” in this manual mean right or left as seen from the operator’s position.

This product is intended for commercial use only.

PARTS AND SERVICE

Repairs, when required, should be performed by your Authorized Advance Service Center, who employs factory trained service personnel, and maintains an inventory of Advance original replacement parts and accessories.

Call the ADVANCE DEALER named below for repair parts or service. Please specify the Model and Serial number when discussing your machine.

(Dealer, affix service sticker here.)

NAMEPLATE

The Model Number and Serial Number of your machine are shown on the name plate, located on the back of the machine near the base of the handle. This information is often needed when ordering repair parts for the machine. Use the space below to note the Model Number and Serial Number of your machine for future reference.

MODEL NUMBER _____

SERIAL NUMBER _____

UNCRATING

When the machine is delivered, carefully inspect the shipping carton and the machine for damage. If damage is evident, save the shipping carton so it can be inspected by the trucking company that delivered it. Contact the trucking company immediately to file a freight damage claim.

IMPORTANT SAFETY INSTRUCTIONS

When using an electrical appliance, basic precautions should always be followed, including the following:

Read all instructions before using.

WARNING!

To reduce risk of fire, electric shock, or injury:

- 1 Do not leave the appliance when it is plugged in. Unplug the unit from the outlet when not in use and before servicing.
- 2 To avoid electric shock, do not expose to rain. Store indoors.
- 3 Do not allow to be used as a toy. Close attention is necessary when used by or near children.
- 4 Use only as described in this manual. Use only manufacturer's recommended attachments.
- 5 Do not use with damaged cord or plug. If appliance is not working as it should, has been dropped, damaged, left outdoors, or dropped into water, return it to a service center.
- 6 Do not pull or carry by cord, use cord as a handle, close a door on a cord, or pull cord around sharp edges or corners. Do not run appliance over cord. Keep cord away from heated surfaces.
- 7 Do not unplug by pulling on cord. To unplug, grasp the plug, not the cord.
- 8 Do not handle plug or appliance with wet hands.
- 9 Do not put any object into openings. Do not use with any opening blocked; keep free of dust, lint, hair, and anything that may reduce air flow.
- 10 Keep hair, loose clothing, fingers, and all parts of body away from openings and moving parts.
- 11 Do not pick up anything that is burning or smoking, such as cigarettes, matches, or hot ashes.
- 12 Turn off all controls before unplugging.
- 13 Use extra care when cleaning on stairs.
- 14 Do not use to pick up flammable or combustible liquids such as gasoline or use in areas where they may be present.
- 15 Connect to a properly grounded outlet only. See Grounding Instructions.

SAVE THESE INSTRUCTIONS

IMPORTANTES MESURES DE SÉCURITÉ

L'utilisation d'un appareil électrique demande certaines précautions:

LIRE TOUTES LES INSTRUCTIONS AVANT DE FAIRE FONCTIONNER (CET APPAREIL)

AVERTISSEMENT:

Pour réduire les risques d'incendie, de choc électrique ou de blessure:

- 1 Ne pas laisser l'appareil sans surveillance lorsqu'il est branché. Débrancher lorsque l'appareil n'est pas utilisé et avant l'entretien.
- 2 Pour réduire les risques de choc électrique, utiliser à l'intérieur seulement.
- 3 Ne pas permettre aux enfants de jouer avec l'appareil. Une attention particulière est nécessaire lorsque l'appareil est utilisé par des enfants ou à proximité de ces derniers.
- 4 N'utiliser que conformément à cette notice avec les accessoires recommandés par le fabricant.
- 5 Ne pas utiliser si le cordon ou la fiche est endommagé. Retourner l'appareil à un atelier de réparation s'il ne fonctionne pas bien, s'il est tombé ou s'il a été endommagé, oublié à l'extérieur ou immergé.
- 6 Ne pas tirer soulever ou traîner l'appareil par le cordon. Ne pas utiliser le cordon comme une poignée, le coincer dans l'embrasure d'une porte ou l'appuyer contre des arêtes vives ou des coins. Ne pas faire rouler l'appareil sur le cordon. Garder le cordon à l'écart des surfaces chaudes.
- 7 Ne pas débrancher en tirant sur le cordon. Tirer plutôt la fiche.
- 8 Ne pas toucher la fiche ou l'appareil lorsque vos mains sont humides.
- 9 N'insérer aucun objet dans les ouvertures. Ne pas utiliser l'appareil lorsqu'une ouverture est bloquée. S'assurer que de la poussière, de la peluche, des cheveux ou d'autres matières ne réduisent pas le débit d'air.
- 10 Maintenir les cheveux, les vêtements amples, les doigts et toutes les parties du corps à l'écart des ouvertures et des pièces mobiles.
- 11 Ne pas aspirer de matières en combustion ou qui dégagent de la fumée, comme des cigarettes, des allumettes ou des cendres chaudes.
- 12 Mettre toutes les commandes à la position ARRÊT avant de débrancher l'appareil.
- 13 User de prudence lors du nettoyage des escaliers.
- 14 Ne pas aspirer des liquides inflammables or combustibles, comme de l'essence, et ne pas faire fonctionner dans des endroits ou peuvent se trouver de tels liquides.
- 15 Ne brancher qu'à une prise de courant avec mise à la terre. Voir les instructions visant la mise à la terre.

CONSERVER CES INSTRUCTIONS

GROUNDING INSTRUCTIONS

WARNING!

This machine must be properly grounded to protect the operator from electrical shock. Read the safety instructions below before operating this machine.

120 volt machines have this kind of three-prong plug at the end of a three-wire electrical cord. The grounding pin on this plug grounds the machine when it is plugged into a three-prong outlet.

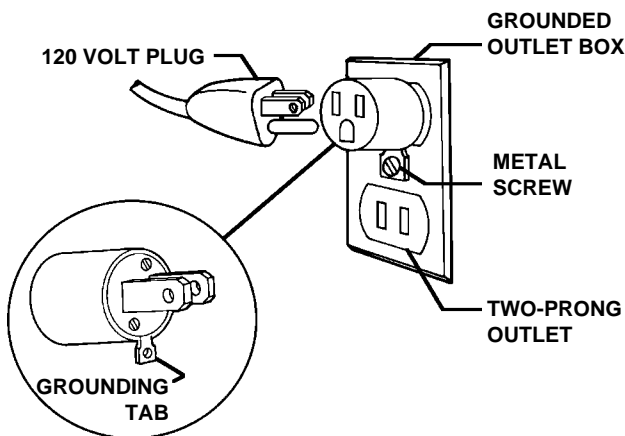
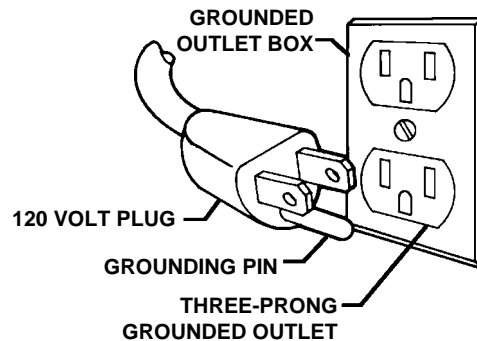

A grounding adapter must be installed as shown here if only two-prong outlets are available. The outlet box must be grounded and the grounding tab (or wire) on the adapter must be installed under the head of the screw in the center of the outlet cover. Grounding adapters for 120 volt plugs are available at most hardware stores.

Grounding adapters are not approved for use in Canada.

-
- Replace the plug if the grounding pin is damaged or broken.
 - The green (or green/yellow) wire in the cord is the grounding wire. When replacing a plug, this wire must be attached to the grounding pin only.
 - Extension cords connected to this machine should be 12 gauge, three-wire cords with three-prong plugs and outlets. Do not use extension cords more than 50 feet (15 m) long.

PREPARING THE FLOOR

Before each use of this machine, the floor must be clean and completely dry. Clean the floor with an automatic floor scrubber or a damp mop, using a solution of water and neutral cleaner.

CAUTION!

This machine should be used only on floors that are coated with a floor finish suitable for burnishing. Contact your local Advance Distributor for further information on floor finishing products.

PREPARING THE MACHINE FOR USE

WARNING!

Moving parts - To reduce the risk of injury, unplug before servicing.

INSTALLING THE PAD

To install a pad, tip the machine back on it's handle. Remove the Pad Retainer (in the center of the pad holder) by turning clockwise to loosen.

Put the proper size pad on the pad holder. Re-install the Pad Retainer by turning counter-clockwise to tighten.

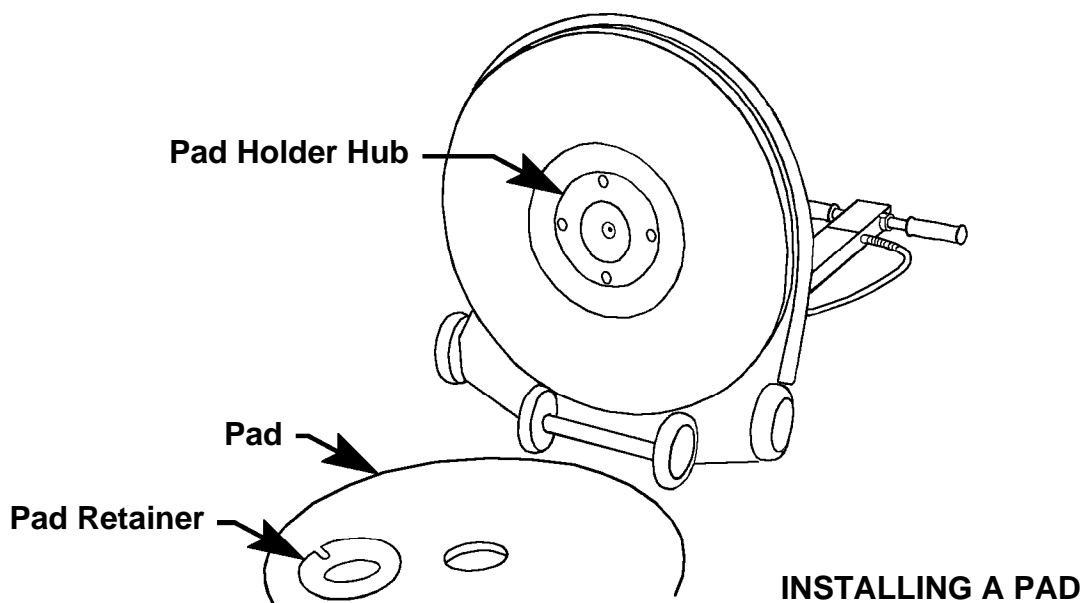

OPERATING CONTROLS

- 1 Handle
- 2 Twist Grip Lock Button
- 3 Twist Grips
- 4 Power Cord
- 5 Handle Release Lever

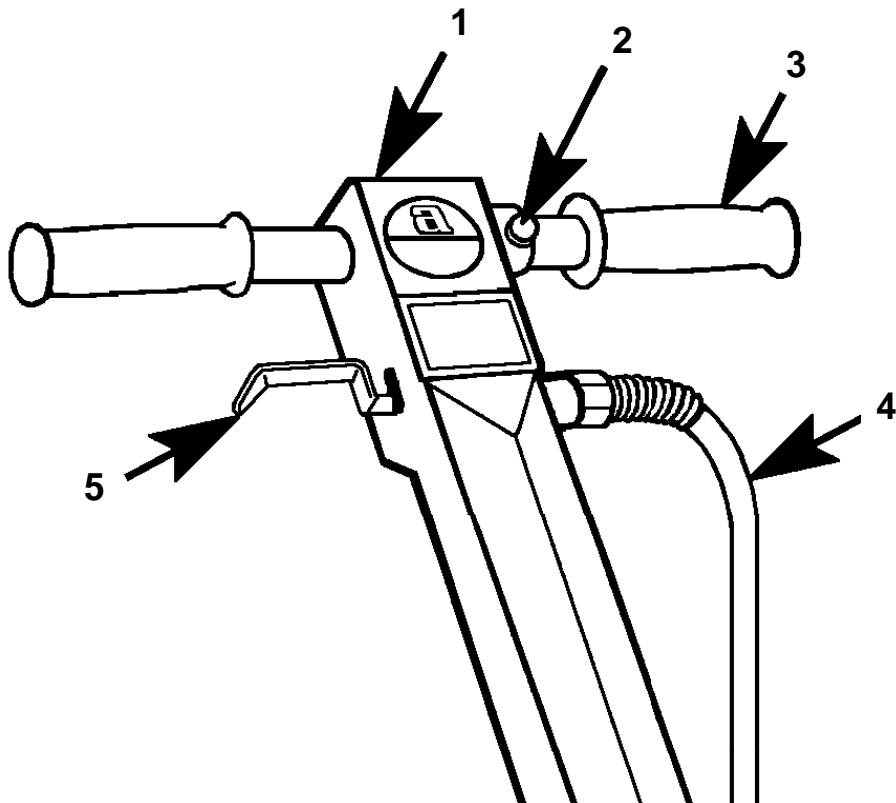

OPERATING THE MACHINE

- 1 Plug the Power Cord (4) into a properly grounded electrical outlet.
- 2 Pull the Handle Release Lever (5) UP and lower the Handle (1) to a comfortable operating position. It is normal for the base of the machine to lift off of the floor slightly when the handle is lowered. It will pull itself down against the floor as soon as the motor is started.
- 3 Push the Twist Grip Lock Button (2) IN and turn the Twist Grips (3) to start the motor. Release the Twist Grips to stop the motor.
- 4 Push the machine forward in a straight line, at a slow walking speed. Overlap each pass about 1 inch (25 mm). Do not use a back and forth motion when operating this machine.
- 5 When using a polishing pad, check every 15 minutes to see if the pad is loaded up with wax and dirt. If it is, turn the pad over to expose the clean side, or install a clean pad.

AFTER USING THE MACHINE

- 1 Lift the Handle until it locks in the upright position.
- 2 Unplug the Power Cord and wrap it around the cord hook and the right Twist Grip.
- 3 Tip the machine back and remove the pad.
- 4 Wash the pad in warm soapy water, rinse completely and hang it up to dry. Do not use the pad again until it is completely dry.
- 5 Store the machine in a clean, dry place.

AIR FILTER

The air filter on top of the motor must be cleaned once a month. To clean the filter, remove the 3 screws from the motor cover, lift the cover off and remove the filter from its holder. Wash the filter with warm water and allow it to dry completely before putting it back on the machine.

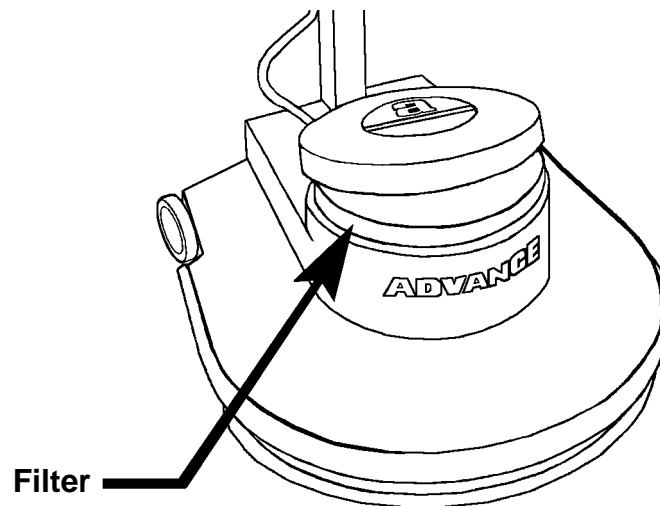

MOTOR BRUSHES

Some models are equipped with a motor brush wear indicator light. When this light glows, **STOP USING THE MACHINE** and contact your local Advance distributor to have the motor serviced.

CAUTION!

The motor can be severely damaged if the machine is used with the light glowing.

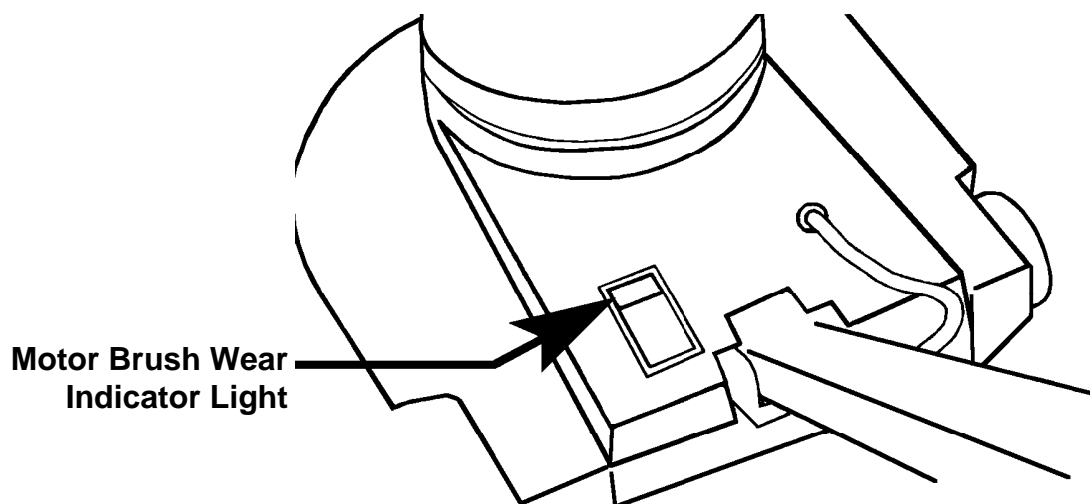

TROUBLESHOOTING

MACHINE VIBRATES

- 1 Pad not centered. Remove the pad, center and reinstall.
- 2 Pad defective - Replace.

SWIRL MARKS

- 1 Pad or brush too aggressive for the floor finish.
- 2 Dirty pad or brush. Check, clean or replace.

RED LIGHT GLOWS

- 1 Worn motor brushes. Have motor brushes replaced by local Advance Distributor.



Nilfisk-Advance, Inc.
14600 21st Avenue North
Plymouth, MN, 55447-3408
www.nilfisk-advance.com
Phone: 800-989-2235
Fax: 800-989-6566
©2000 Nilfisk-Advance, Inc.,
Plymouth, MN 55447-3408
Printed in the U.S.A.