



Service Manual

Advance Models:

56381032 (X4030D-EcoFlex)

56381033 (X4030C-EcoFlex w/Side Broom)

56381034 (X4530D-EcoFlex)

56381035 (X4530C-EcoFlex w/Side Broom)

56381036 (X4830D-EcoFlex)

56381037 (X4830C-EcoFlex w/Side Broom)

56381043 (X4030C-EcoFlex w/o Side Broom)

56381044 (X4530C-EcoFlex w/o Side Broom)

56381045 (X4830C-EcoFlex w/o Side Broom)

Nilfisk Models:

56413006 (BR1000 S EcoFlex w/o Side Broom)

56413010 (BR1300 S EcoFlex w/o Side Broom)

56413007 (BR1000 S C EcoFlex w/Side Broom)

56413011 (BR1300 S C EcoFlex w/Side Broom)

Contents

General Information	8
Introduction	8
Revision History	8
Parts and Service.	8
Nameplate	8
Transporting the Machine	9
Towing	9
Other Manuals Available for Your Machine	9
Electronic Databases	9
Manuals	9
Caution and Warning Symbols	10
General Safety Instructions	10
Emergency-stop Switch/Battery Disconnect	12
Technical Specifications	13
General Specifications Common to All Models	13
Specifications Common to Deck Size	14
Dimensions	15
General Machine Overview	16
Major Machine Components.	16
Control Panel.	18
Switch and Button Functions	18
Control Panel Indicators	21
Control Panel Display	23
Caution Displays	23
Circuit Breakers	24
General Maintenance	24
Maintenance After Use	24
Maintenance Schedule.	25
Machine Lubrication.	26
Lubrication Points	26
Chassis System	29
Major Chassis Components	29
Control System	30
Functional Description	30
Overview	30
A2 Control Board Assembly.	30
A3 Switch/Display Panel Assembly.	31
Control System Wiring Diagram	31
Circuit Description.	31
Main Control Programming Options	32
Fault Recall Mode	32
To Select the Battery Used in the Machine.	32
To Restore the Scrub Pressures to the Factory Default Settings	32
To Enable/Disable the Fault Detection	33
To Display the Control Board Revision Level	33
Monitor Mode	33
Scrub Deck Down Time Adjustment	34
Normal (Light) Scrub Setting Adjustment	34
Heavy Scrub Setting Adjustment	35
Extreme Scrub Setting Adjustment.	36
Scrub Speed Switch Lockout	37

Detergent System Selection Mode	37
EcoFlex™ Mode Selection	38
Vacuum Motor Configuration Option	38
Recovery Tank Full Detection Enable/Disable	38
Solution Flow in Reverse Enable/Disable	39
Indicator LED Intensity Selection Option	39
Detergent and Solution Pump Purge	40
Method 1	40
Method 2 (as described in the Instructions for Use)	40
Side Broom Function	40
Side Broom Height Adjustment	41
Display Mode Selection	41
Service Test Mode	42
To Enter the Service Test Mode	42
Service Test Mode Display	42
Control Panel Switch and Button Functions	42
Troubleshooting	44
Error Indicator and Error Code Display	44
Error Codes	45
Removal and Installation	51
A2 Control Board Assembly	51
Specifications	52
I/O Tables	53
A2 Control Board Assembly	53
EcoFlex PCB Assembly	56
Electrical System	57
Functional Description	57
Overview	57
Condor EcoFlex™ Ladder Wiring Diagram	58
Low-voltage Cut-out Feature	59
Battery Condition Indicator	59
Battery Location	60
Maintenance and Adjustments	60
Wet-cell Battery Maintenance	60
Checking the Battery Water Level	61
Charging Wet-cell Batteries	61
To Charge the Batteries	61
When Servicing Batteries	61
Troubleshooting	62
Battery Testing	62
General Troubleshooting	62
Removal and Installation	63
To Install the Batteries	63
Specifications	64
Special Tools	64
Options and Accessories	65
Brush Selector Guide	65
4030D Pad Holders and Disc Brushes (two required)	65
4030C Cylindrical Brushes and Side Brooms (two of each required)	65
4530D Pad Holders and Disc Brushes (three required)	66
4530C Cylindrical Brushes and Side Brooms (two of each required)	66
4830D Pad Holders and Disc Brushes (three required)	66
4830C Cylindrical Brushes and Side Brooms (two of each required)	67
4030C/D Squeegee Kits	67
4530C/D Squeegee Kits	67

4830C/D Squeegee Kits	68
Options and Accessories	68
Batteries and Chargers	69
Deck Kits (includes deck and squeegee, brushes sold separately)	69
Extended Warranty	69
Recovery System	70
Functional Description	70
Overview	70
Recovery Tank	70
Vacuum Motor	70
Squeegee and Squeegee Hose	70
Float Cage and Ball	71
Recovery System Wiring Diagram	71
Circuit Description.	72
Component Locations	72
Vacuum Motor and Vacuum Hose.	72
Top Cover Assembly	73
Float Cage and Ball	73
Recovery Tank Lid	74
Squeegee and Drain Hoses	74
Maintenance	75
To Inspect and Clean the Vacuum Filter and Inlet Screen	75
To Inspect and Clean the Vacuum Motor Float Cage	75
Troubleshooting	76
Removal and Installation	77
Recovery Tank	77
Vacuum Motor	78
Specifications	80
Special Tools	80
Scrub System, Cylindrical	81
Functional Description	81
Overview	81
Cylindrical Scrub System Wiring Diagram.	81
Circuit Description.	82
Component Locations	83
Maintenance and Adjustments	83
General Scrub System Maintenance	83
Daily Maintenance	83
Weekly Maintenance	84
Monthly Maintenance.	84
Scrub Brush Belt Replacement	84
Lift Actuator Adjustment	85
Using the Actuator Power Cord Adapter	85
Drive Nut Adjustment.	86
Side Skirt Replacement and Adjustment	88
Troubleshooting	90
Removal and Installation	92
Scrub Brushes	92
Scrub Brush Deck	93
Scrub Deck Lift Actuator	95
Scrub Brush Motor.	96
Specifications	97
Special Tools	97
Scrub System, Disc	98
Functional Description	98

Overview	98
Disc Scrub System Wiring Diagram	98
Circuit Description.	99
Component Locations	100
Maintenance and Adjustments	101
Lift Actuator Adjustment	101
Using the Actuator Power Cord Adapter	101
Drive Nut Adjustment.	102
Side Skirt Replacement and Adjustment	104
Troubleshooting	106
Removal and Installation	109
Scrub Brush Deck	109
Scrub Deck Lift Actuator	110
Scrub Brush Motor and Gearbox	111
To Remove and Install a Gearbox Assembly	111
To Disassemble and Reassemble a Gearbox Assembly	111
Specifications	112
Special Tools	112
Solution System.	113
Functional Description	113
Overview	113
Solution Tank	114
Shutoff Valve.	114
Drain Hose and Hose Cap	114
Solution Filter	114
Solution Control Pump	114
Solution Solenoid Valve	114
Solution Manifold (disc decks only)	114
Accessory Pump	114
Detergent Tank and Pumps	115
Solution System Wiring Diagram	115
Circuit Description.	115
Solution System	115
Detergent System	116
Accessory Pump	116
Component Locations	117
Shutoff Valve.	117
Drain Hose and Hose Cap	117
Solution Filter	117
Solution Control Pump	118
Solution Solenoid Valve	118
Solution Manifold (disc decks only)	118
Accessory Pump	119
Detergent Tank and Pumps	119
Maintenance and Adjustments	120
To Disassemble and Clean the Solution Solenoid Valve	120
Weekly Maintenance.	120
To Empty and Rinse the Solution Tank	120
To Clean the Solution Filter	121
To Clean the Solution Delivery Trough (cylindrical scrub decks only)	121
To Purge the Detergent System.	122
To Purge the Detergent System When Changing Detergents	122
To Program the Detergent Ratio	122
Troubleshooting	123
Removal and Installation	124
Solution Control Pump	124

Solution Solenoid Valve	125
Specifications	126
Solution Flow Rates	126
Component Specifications	126
Squeegee System	127
Functional Description	127
Overview	127
Squeegee System Wiring Diagram	127
Circuit Description.	127
Squeegee Lift Actuator Reverse Function	128
Component Locations	128
Maintenance and Adjustments	129
To Reverse or Replace the Rear Squeegee Wiping Blade	129
To Reverse or Replace the Front Squeegee Blade	129
Squeegee Adjustment	130
To Adjust the Squeegee Angle	130
To Adjust the Squeegee Blade Height	130
Lift Actuator Adjustment	131
Using the Actuator Power Cord Adapter	131
Actuator Drive Nut Adjustment	131
Troubleshooting	132
Removal and Installation	133
Squeegee Lift Actuator	133
Specifications	134
Special Tools	134
Sweep System, Side Broom	135
Functional Description	135
Overview	135
Side Broom Sweep System Wiring Diagram	135
Circuit Description.	136
Component Locations	136
Maintenance and Adjustments	137
Side Broom Height Adjustment	137
Lift Actuator Adjustment	138
Using the Actuator Power Cord Adapter	138
Lift Actuator Drive Nut Adjustment	138
Troubleshooting	140
Removal and Installation	141
Side Broom Lift Actuator	141
Side Broom Gearmotor	142
Specifications	143
Special Tools	143
Wheel System, Non-traction.	144
Functional Description	144
Overview	144
Component Locations	144
Maintenance and Adjustments	145
Brake Cable Replacement	145
Brake Cable Adjustment	146
Brake Caliper Pad Wear Adjustment	147
Troubleshooting	147
Removal and Installation	148
Rear Wheel and Brake Caliper	148
Wheel System, Traction	150

Functional Description	150
Overview	150
Drive Wheel Assembly	150
Curtis A1 Speed Controller	150
Drive Wheel Steering Assembly	151
Drive Pedal Assembly	151
Traction Wheel System Wiring Diagram	152
Circuit Description	152
Component Locations	153
Drive Wheel Assembly	153
Curtis A1 Speed Controller	153
Drive Wheel Steering Assembly	153
Drive Pedal Assembly	153
Interlock Switches	153
Maintenance and Adjustments	154
Steering Chain	154
Curtis Speed Controller	154
Programming Vehicle Speed Changes	154
Troubleshooting	155
General Troubleshooting	155
Curtis Controller Diagnostics	155
Diagnostics Method A	155
Diagnostics Method B	156
Diagnostic History	156
Status LED Fault Codes	157
Removal and Installation	159
Steering Chain Removal and Tensioning	159
Front Drive Tire	160
Steering Spindle and Wheel Drive Assembly	161
Electric Drive Motor	162
Carbon Motor Brush Inspection and Replacement	163
Potentiometer Removal and Testing	164
Potentiometer Removal	164
Potentiometer Testing	164
Potentiometer Installation and Adjustment	165
Alternate Method for Throttle Adjustment	166
Drive Pedal Neutral Adjustment and Pedal Replacement	167
To Adjust the Pedal Spring	167
To Replace the Pedal or Spring	168
Installation Checkout for the Curtis Speed Controller	168
Specifications	170
General Specifications	170
A1 Speed Controller Pin Key Detail	170
A1 Speed Controller 16-Pin Connector Detail	171
Speed Control Table	171
Special Tools	171
Appendix	172
Electrical Component Locations	172
Ladder Diagram, Rev. G	173
Wiring Diagram, Rev. I	174
Detergent (EcoFlex™) System Plumbing Schematic	175
Detergent (EcoFlex™) System Preparation and Purging	176
Preparations for Use	176
To Purge the Detergent System	176
To Purge the Detergent System When Changing Detergents	176

General Information

Introduction

This manual will help you get the most from your Advance rider scrubber. Read it thoroughly before servicing the machine.

Revision History

- 11/13
 - General Information - Corrected metric values for Max. Wheel Floor Loading Specifications
 - Control System - Added Programming Options instructions for battery type setting.

Parts and Service

Repairs should be performed by your Authorized Advance Service Center, which employs factory-trained service personnel and maintains an inventory of Advance original replacement parts and accessories.

Call the Advance dealer named below for repair parts or service. Please specify the Model and Serial Number when discussing your machine.

Nameplate

The Model Number and Serial Number of your machine are shown on the machine nameplate. This information is needed when ordering repair parts for the machine. Use the space below to note the Model Number and Serial Number of your machine for future reference.

Model Number: _____

Serial Number: _____

Note that the **Nameplate** is attached to the rear of the steering column.

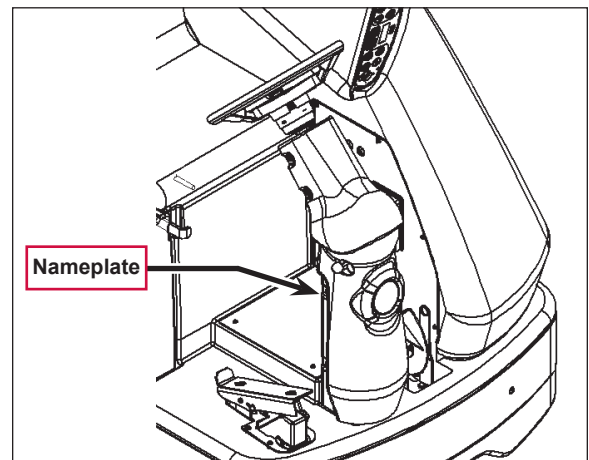

Transporting the Machine



Caution! Before transporting the machine on an open truck or trailer, make sure that:

- The machine is tied down securely.
- All access doors and covers are secured (tape and strap as needed).
- The battery/batteries are disconnected.

Towing



Caution! If the machine must be towed or pushed, make sure the Master On/Off Key Switch is in the Off position. Do not move the machine faster than a normal walking pace (2-3 mph, 3-5 kph) and for short distances only.



Note: Disconnecting the wheel drive motor wiring connector will make a disabled machine easier to push.

Other Manuals Available for Your Machine

Electronic Databases

The manuals listed below can be found on Advance's electronic supported databases. They are:

- Advance Dealer Customer Zone
- EzParts service / parts CD-ROM
- Nilfisk-Advance website: www.nilfisk-advance.com

Manuals

- Parts List - Form Number 56042467
- Instructions for Use - Form Number 56041986 (English, Spanish)
- Curtis Programmer Manual Number 56043101

Caution and Warning Symbols

Advance uses the symbols below to signal potentially dangerous conditions. Read this information carefully and take the necessary steps to protect personnel and property.



Danger! Is used to warn of immediate hazards that will cause severe personal injury or death.



Warning! Is used to call attention to a situation that could cause severe personal injury.



Caution! Is used to call attention to a situation that could cause minor personal injury or damage to the machine or other property.



Read all instructions before using.

General Safety Instructions

Specific Cautions and Warnings are included to warn you of potential danger of machine damage or bodily harm.



Warning!

- **This machine is to be used only by correctly trained and authorized persons.**
- **Avoid sudden stops while on ramps or inclines when the tanks are full. Avoid abrupt sharp turns. Use low speed down hills. Clean only while ascending (driving up) the ramp.**
- **Keep sparks, flame and smoking materials away from batteries. Explosive gases are vented during normal operation.**
- **Charging the batteries produces highly-explosive hydrogen gas. Charge batteries only in well-ventilated areas, away from open flame. Do not smoke while charging the batteries.**
- **Remove all jewelry when working near electrical components.**
- **Turn the key switch off (O) and disconnect the batteries before servicing electrical components.**
- **Never work under a machine without safety blocks or stands to support the machine.**
- **Do not dispense flammable cleaning agents, operate the machine on or near these agents, or operate in areas where flammable liquids exist.**
- **Only use the brushes provided with the machine or those specified in the instruction manual. The use of other brushes may impair safety.**

**Caution!**

- *This machine is not approved for use on public paths or roads.*
- *This machine is not suitable for picking up hazardous dust.*
- *Do not use scarifier discs and grinding stones. Advance will not be held responsible for any damage to floor surfaces caused by scarifiers or grinding stones. (This can also damage the brush drive system.)*
- *When operating this machine, ensure that third parties, particularly children, are not endangered.*
- *Before performing any service function, carefully read all instructions pertaining to that function.*
- *Do not leave the machine unattended without first turning the key switch off (O), removing the key and applying the parking brake.*
- *Turn the key switch off (O) and remove the key before changing the brushes, and before opening any access panels.*
- *Take precautions to prevent hair, jewelry or loose clothing from becoming caught in moving parts.*
- *Use caution when moving this machine in below-freezing temperature conditions. Any water in the solution, recovery or detergent tanks, or in the hose lines could freeze, causing damage to valves and fittings. Drain the tanks and purge with windshield washer fluid.*
- *The batteries must be removed from the machine before the machine is scrapped. The disposal of the batteries should be done safely and in accordance with your local environmental regulations.*
- *Do not use on surfaces having a gradient exceeding that marked on the machine.*
- *All doors and covers are to be positioned as indicated in the instruction manual before using the machine.*



Caution! *Do not pressure-wash the operator control panel, circuit breaker panel or any electrical areas of the machine.*

Emergency-stop Switch/Battery Disconnect

The **Emergency-stop/Battery Disconnect** is the red lever located to the right of the Operator's seat. In the event of an emergency, press the **Emergency-stop/Battery Disconnect** in (toward the rear of the machine) to disconnect the battery from the machine. This will stop all machine functions.

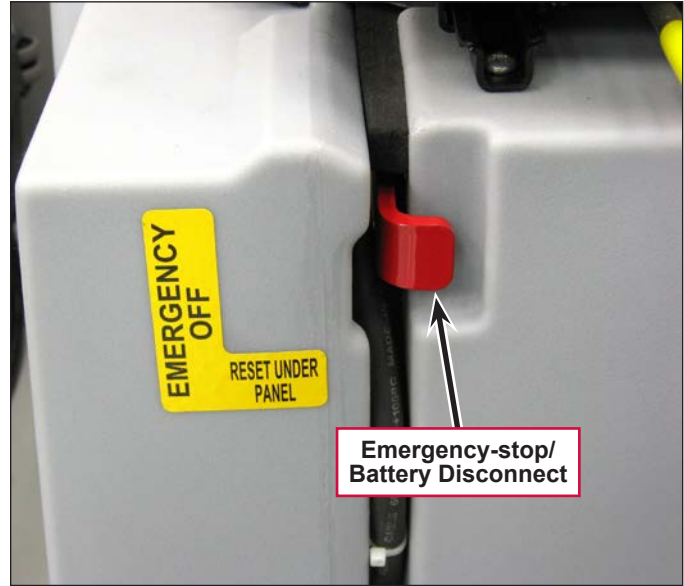

Save These Instructions

Technical Specifications

General Specifications Common to All Models

Machine Length	73.5 in. [187 cm]
Machine Height	58.5 in. [148.6 cm]
Machine Height (w/overhead guard)	84 in. [213 cm]
Machine Body Width	40 in. [101.6 cm]
Solution Tank Capacity	70 gal. [265 L.]
Recovery Tank Capacity	70 gal. [265 L.]
Sound pressure level as per IEC 60704-1 (at operator)	72 dB(A)
Vibrations at the Hand Controls (ISO 5349-1)	1.12 m/s ²
Vibrations at the Seat (EN 1032)	0.35 m/s ²
Transport Speed (Fwd. Maximum)	5.5 mph [8.9 kph]
Transport Speed (Rev. Maximum)	4.8 mph [7.7 kph]
Gradeability (Transport)	14.5% / 8°
Gradeability (Working –Scrubbing)	10.5% / 6°
Wheel Drive Motor	1.75 HP, 1300 watt
Vacuum Motor (3 stage)	.75 HP, 560 watt
Vacuum Water Lift for one motor	(Sealed) 68 in.
	(Open Hole Adapter 1") 14 in.
Vacuum Water Lift for two motors	(Sealed) 74 in.
	(Open Hole Adapter 1") 27 in.
Power Source (Batteries)	
Battery Weight (395 amp) STD (6) 6 volt @ 20 hour rate	121 lbs. [55 kg]
Battery Weight (450 amp) Opt. (1) Mono-block @ 20 hour rate	919 lbs. [417 kg]
Battery Compartment Size (approximate)	
Height (Max.)	19 in. [48.2 cm]
Width (Max.)	20 in. [50.8 cm]
Length (Max.)	31.75 in. [80.6 cm]
Maximum Wheel Floor Loading (Center Front)	116 psi / 8.2 kg/cm ²
Maximum Wheel Floor Loading (Left Rear)	86 psi / 6.0 kg/cm ²
Maximum Wheel Floor Loading (Right Rear)	81 psi / 5.7 kg/cm ²

Battery Chargers – see the [Electrical System/Specifications](#) section.

Specifications Common to Deck Size

Model designations: 40" = Condor 4030 D/C; 45" = Condor 4530 D/C; 48" = Condor 4830 D/C

		40"	45"	48"
Machine Width with Squeegee	English	49 in. "F"	54 in. "G"	57 in. "H"
	Metric	78 cm "F"	87 cm "G"	91 cm "H"
Scrub Brush Size				
Brush Diameter - Disc		(2) 20 in. [50.8 cm]	(3) 16 in. [40.6 cm]	(3) 17 in. [43 cm]
Outside Scrub Brush Diameter - Cylindrical (inside core is 5 in.)		8.5 in. [21.6 cm]	8.5 in. [21.6 cm]	8.5 in. [21.6 cm]
Scrub Brush Length (two per machine)		38.37 in. [97.4 cm]	43.62 in. [110.8 cm]	46.62 in. [118.4 cm]
Scrub Brush Motors	Disc	(1) 3.0 HP 2240 watts	(3) 1.5 HP 1120 watts	(3) 1.5 HP 1120 watts
	Cylindrical	All Cylindrical Models use (2) 1.5 HP 1120 watts -		
Scrub Brush Speed	Disc	240 RPM	225 RPM	225 RPM
	Cylindrical	630 RPM	630 RPM	630 RPM
Minimum Aisle Turn Width		84 in. [214 cm]	84 in. [214 cm]	84 in. [214 cm]
Machine Net Weight*	English	1,845 lbs.	1,845 lbs.	1,845 lbs.
	Metric	837 kg	837 kg	837 kg
Machine Gross Weight**	English	3,545 lbs.	3,545 lbs.	3,545 lbs.
	Metric	1608 kg	1608 kg	1608 kg
Cleaning Width (scrubbing path)	English	40 in.	45 in.	48 in.
	Metric	101 cm	114 cm	122 cm
Coverage Rate Per Hour	English @ 3.5 mph	61,600 ft ²	69,300 ft ²	73,920 ft ²
	Metric @ 5.6 kph	5722 m ²	6438 m ²	6867 m ²

* **Net Weight:** Standard machine without options, empty solution and recovery tanks, without removable scrub brushes and no batteries installed.

** **Gross Weight:** Standard machine without options, full solution tank and empty recovery tank, with removable scrub brushes and 450 AH batteries.

*** Listings for watts are maximum values.

Dimensions

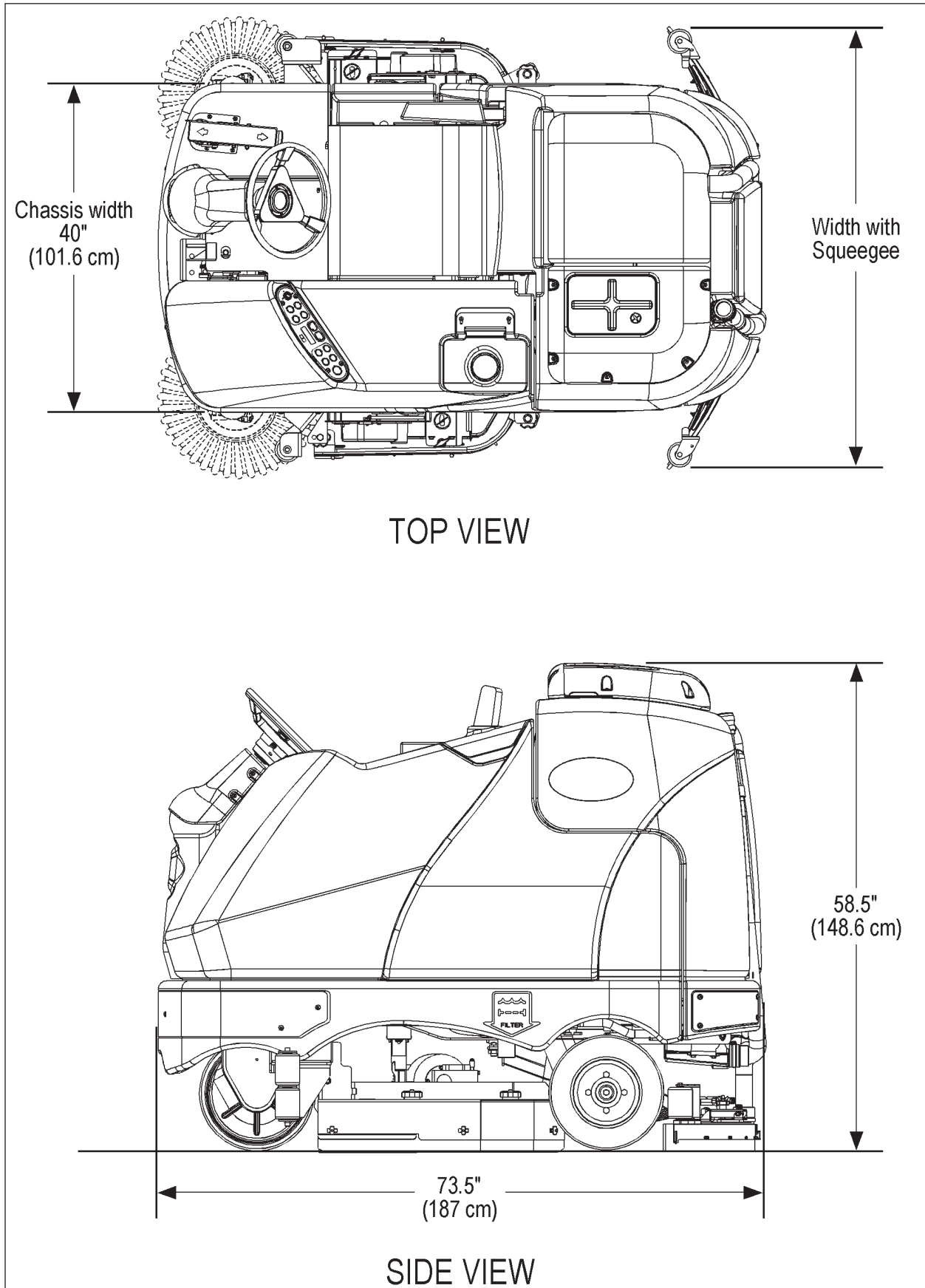

General Machine Overview

Major Machine Components

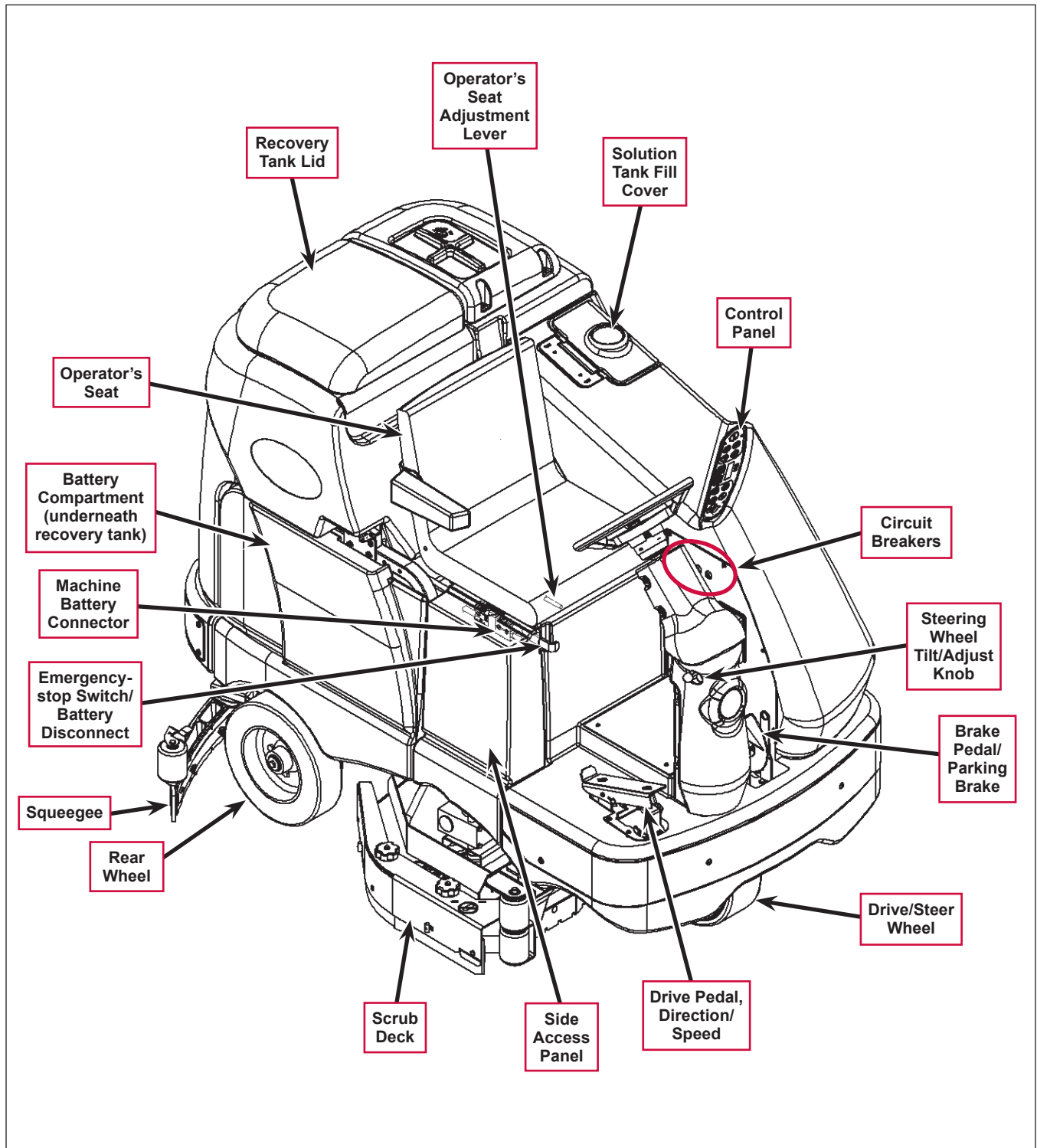

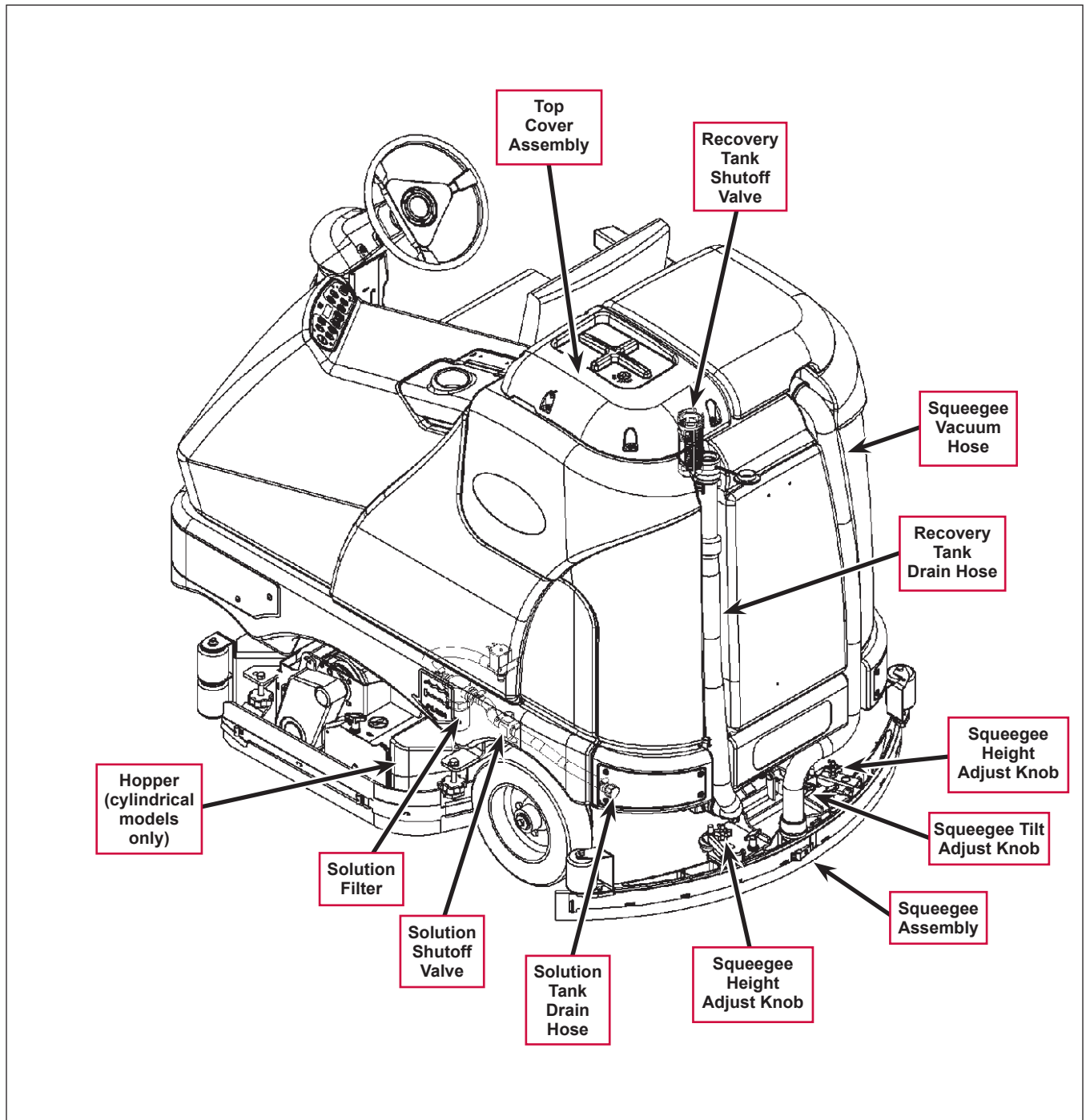

Control Panel

Switch and Button Functions

The controls on your rider scrubber were designed with *one-touch operation* in mind. For single-pass scrubbing, the user can simply depress one switch and all systems on the machine will be ready to go. For most single-pass scrubbing operations, the operator should only need to use the middle switches on the control panel. These are the red **Scrub Off** and the green **Scrub On/Pressure Increase** switches.

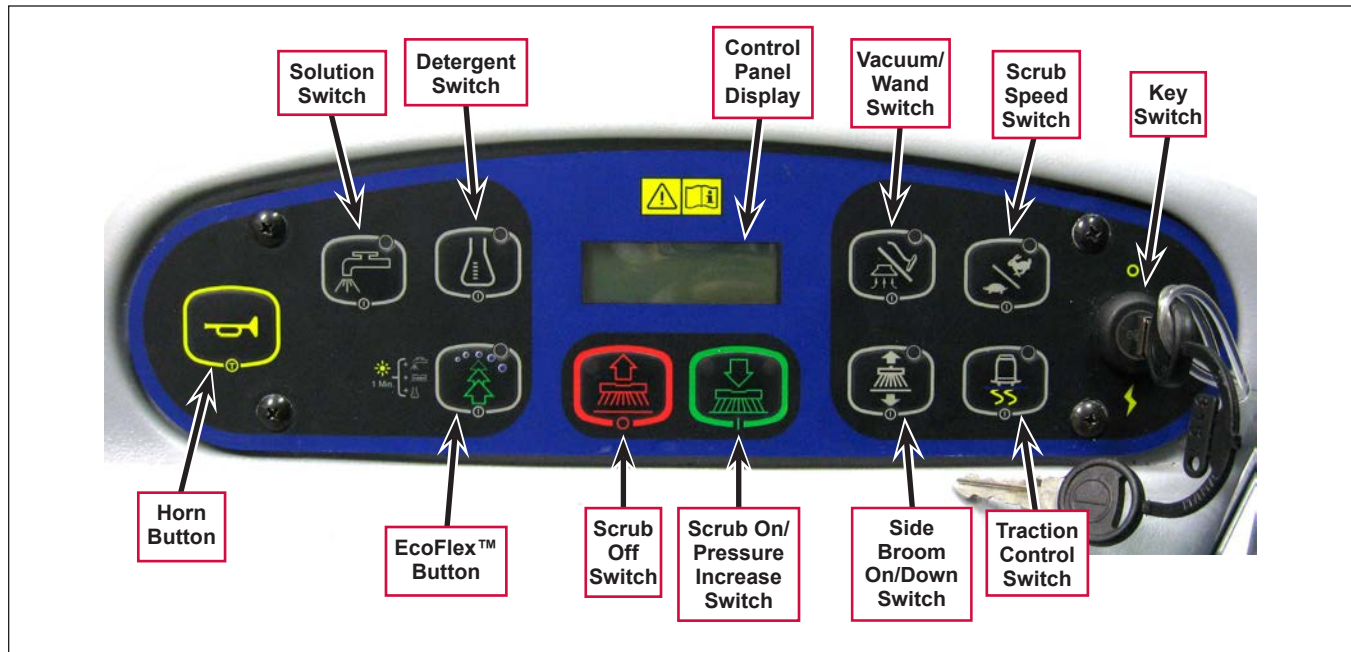

- **Key Switch** – main power switch; controls the battery input to the machine’s main control board and the wheel drive speed control.
- **Scrub On/Pressure Increase Switch** – functions as follows:

If the scrub system is off, pressing this switch once will put the machine into the Auto Scrub mode. The following will occur:

- The scrub system will be enabled with the scrub pressure set to the #1 normal setting.



Note: Press the switch twice for #2 heavy scrub setting, and three times for the #3 extreme scrub setting. Pressing the switch a fourth time will return the system to the normal scrub setting.

- The scrub deck and squeegee will automatically be lowered. On cylindrical models equipped with side brooms, the side brooms will be lowered.
- The vacuum system will be enabled.
- The solution and detergent systems will be enabled. Note that both the solution and detergent flow rates will correspond to the selected scrub pressure mode.
- As soon as the drive pedal is moved from its neutral position, the scrub brushes and side brooms (if installed) will start turning, and the solution, detergent and vacuum systems will switch on.

- If the direction is forward, the solution and detergent flow will also start automatically.
- If the direction is reverse, the solution and detergent flow will be stopped and the squeegee will be raised just enough to clear the floor surface.



Note: *The solution, vacuum and detergent systems are automatically enabled when the **Scrub On Switch** is pressed to put the machine into the Auto Scrub mode. Any individual system can be toggled off and on by simply pressing the corresponding system switch at any time during scrubbing.*

If the machine is already scrubbing, pressing the **Scrub On/Pressure Increase Switch** will increase the scrub pressure to the next higher setting (toggling from regular to heavy, heavy to extreme, then back to normal). The **Scrub Pressure Indicator** will show the selected scrub pressure (one, two or three bars) in the **Control Panel Display**.

- **Scrub Off Switch** – Pressing this switch when the machine is in the scrub mode will cause the following to occur:
 - The scrub brushes will turn off and the scrub deck will be raised to the up position. On cylindrical models equipped with side brooms, the side brooms will shut off and be raised.
 - The solution and detergent flow will be stopped.
 - Once forward machine motion stops, the vacuum/wand switch indicator light will start to blink. After a user-programmable time delay, the squeegee will be raised and the vacuum motors will shut off. Pressing the switch a second time before the vacuum time delay is complete will raise the squeegee and turn off the vacuum motors immediately.
- **Solution Switch** – functions as follows:
 - If the scrub system is off, pressing and holding this switch will switch on the solution flow to pre-wet the floor. The solution flow will stop when the switch is released. Note this must be done prior to pressing the **Scrub On Switch** and putting the machine into the Auto Scrub mode.
 - If the machine is in the Auto Scrub mode, pressing this switch will disable the solution system. This is used if you wish to scrub without adding additional solution to the floor.
 - If the machine is in the Auto Scrub mode, you can use the **Solution Switch** to actuate the solution flow override function. This override function allows you to select a different solution flow rate without changing the scrub pressure. Note that the machine is programmed for two additional higher solution flow rates plus the three normal default flow rates, for a total of five solution flow rates.

To actuate the solution flow override function, press and hold the **Solution Switch** for three seconds until the **Solution System Indicator** flashes, then release it. You'll have three seconds to select the desired solution flow rate by pressing the **Solution Switch**. The **Solution Flow Indicator** will show the selected solution flow rate (one through five bars) in the **Control Panel Display**. Note that if any scrub pressure change is made while in the solution override mode, the solution flow will return to its default solution flow rate.
- **Detergent Switch** – functions as follows:
 - If the solution system is enabled, pressing this switch will toggle the detergent system off and on. When the detergent system is on, the detergent pumps will be activated at a specific rate when the drive pedal is actuated. The detergent pump will turn off when the drive pedal is in neutral or reverse.
 - If the solution system is off, the detergent pump will not turn on.

- **Vacuum/Wand Switch** – functions as follows:
 - If the machine is in the Auto Scrub mode, pressing this switch once will raise the squeegee. The vacuum motors will run for a short time delay, then shut off. If you press the switch twice, the vacuum motors will shut off immediately. This is used if you wish to double-scrub (scrub without recovering the solution).
 - If the scrub system is off, the Vacuum/Wand Switch functions differently depending on whether the seat switch is open (no operator in the seat) or closed (operator in the seat).
 - If the operator is in the seat, pressing the switch will lower the squeegee and switch on the vacuum motors. When the machine is moved into reverse, the squeegee will be raised, then lowered when the machine is again moved forward. This mode is used to pickup water from the floor without scrubbing or adding solution.
 - If the operator is not in the seat, pressing the switch will toggle the vacuum motors on and off to allow use of the vacuum wand. In this mode, the squeegee will not move up or down and the recovery tank full indicator is ignored.
- **Scrub Speed Switch** – When the machine is operating in any one of its scrub settings, the machine's travel speed is reduced to 80 percent of the maximum transport speed pre-programmed into the speed controller. Pressing the **Scrub Speed Switch** overrides the 80 percent of transport speed limit and increases the scrub speed to 100 percent of transport speed.
- **Traction Control Switch** – regulates the drive wheel motor torque to minimize drive wheel slippage and provide better traction.
- **Side Broom On/Down Switch** – lowers and raises the side brooms (only functional on cylindrical models equipped with side brooms). Note that when the scrub system is switched on, the side brooms are lowered to the same position they were in when the scrub system was last turned off (auto memory operating position).



Note: You can raise or lower the side broom height to maintain the correct broom contact patterns and compensate for normal broom wear. Refer to the **Sweep System, Side Broom** section for instructions on setting the side broom height.

- **EcoFlex™ Button** – The **EcoFlex™ Button** functions differently depending on whether the EcoFlex™ mode is set to Mode 1 or Mode 2. (Also refer to the **Control System/Main Programming Options/ EcoFlex™ Mode Selection** section.) Note that in Mode 1 the detergent concentration is displayed as a ratio. In Mode 2 the detergent concentration is displayed as a percent.
 - In EcoFlex™ Mode 1, the detergent ratio is preset to 1:400. Pressing the **EcoFlex™ Button** in Mode 1 will do the following:
 - The detergent ratio will change to the programmed ratio. (Also refer to the **Solution System/ Maintenance and Adjustments/To Program the Detergent Ratio** section.)
 - The scrub pressure will increase to the next highest pressure.
 - The solution flow rate will increase to the next highest rate.

After 60 seconds, or after you press the **EcoFlex™ Button** again, the detergent ratio will revert to 1:400, and the scrub pressure and solution rate will return to their previous settings.

- In EcoFlex™ Mode 2, the default detergent ratio will be the programmed ratio. Pressing the **EcoFlex™ Button** in Mode 2 will do the following:
 - The detergent concentration will change to the next highest (richest) concentration. For example, if the programmed concentration is 0.4%, pressing the **EcoFlex™ Button** will change it to 0.5%. (Also refer to the **Solution System/Maintenance and Adjustments/To Program the Detergent Ratio** section.)
 - The scrub pressure will increase to the next highest pressure.
 - The solution flow rate will increase to the next highest rate.

After 60 seconds, or after you press the **EcoFlex™ Button** again, the detergent ratio will revert to the programmed ratio, and the scrub pressure and solution rate will return to their previous settings.

- **Horn Button** – sounds the horn when pressed.
- **Control Panel Display** – displays the various icons that indicate scrub pressure, solution flow rate, detergent ratio, battery charge state and a recovery tank full condition. The display also shows any error conditions detected by the main control board.

Control Panel Indicators

In general the following guidelines apply to the control panel indicators:

- When the key switch is first turned on all of the blue control panel indicator lights will turn on for one second for an operational test.
- A blue indicator means that a system is on and running, or has been enabled and is ready to switch on when the drive pedal is moved into forward or reverse.
- The indicators will be off when the system is disabled or switched off.
- The green **EcoFlex™ Indicator** will be on when the system is in the low-concentration mode, and flash when the 60-second burst of power function is active.

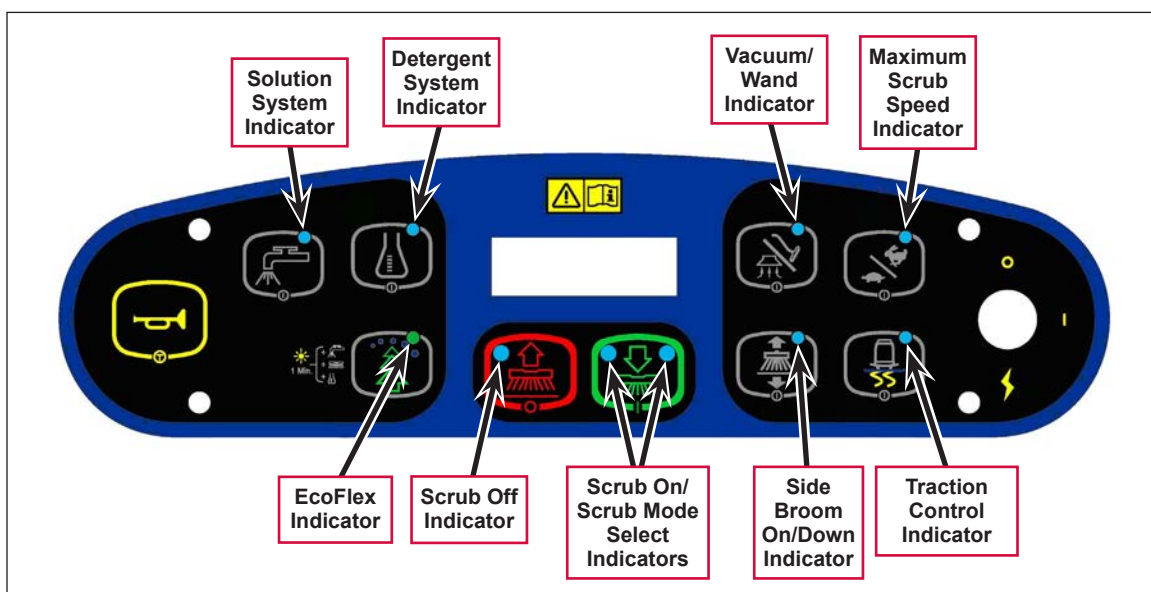

- **Scrub On/Scrub Mode Select Indicator:**
 - The left side indicator will light when the normal scrub mode is selected.
 - The right side indicator will light when the heavy scrub mode is selected.
 - Both the right and left indicators will light when the extreme scrub mode is selected.
 - Both the right and left indicators will be off when the scrub system is off.
- **Scrub Off Indicator:**
 - The indicator will light to indicate that the scrub system is off and is ready to be activated.
 - The indicator will be off when the scrub system is enabled and/or switched on.
- **Solution System Indicator:**
 - The indicator will light when the solution system is enabled and/or is switched on.
 - The indicator will be off when the solution system is off.
 - The indicator will flash when the solution tank (liquid level) float switch senses a low solution level.
- **Detergent System Indicator:**
 - The indicator will light when the detergent system is enabled and/or is switched on.
 - The indicator will be off when the detergent system is off.



Note: *The control board automatically recognizes that the machine has an operational detergent system through its wiring harness connection.*

- **Vacuum/Wand Indicator:**
 - The indicator will light when the vacuum system is enabled and/or is switched on.
 - The indicator will be off when the vacuum system is off.
 - The indicator will flash when the vacuum system is operating in the time delay shutdown mode (normally five to 10 seconds).
- **Maximum Scrub Speed Indicator:**
 - The indicator will light when the maximum 100% transport speed during scrubbing is enabled.
 - The indicator will be off when normal scrub speed is enabled.
- **Traction Control Indicator:**
 - The indicator will light when the traction control mode is enabled.
 - The indicator will be off when the traction control mode is disabled.

- **Side Broom On/Down Indicator:**

- The indicator will be on when the side brooms are in the down working position, enabled and switched on.
- The indicator will be off when the scrub system is switched off and the brooms are in the raised position.

- **EcoFlex Indicator:**

- The (green) indicator will be on when the EcoFlex™ low-concentration detergent mode is enabled.
- The (green) indicator will flash when the EcoFlex™ burst of power mode is enabled.
- The (green) indicator will be off when the EcoFlex™ full-concentration detergent mode is enabled.



Note: When the recovery tank becomes full (when in the auto scrub mode), the vacuum motors and all other systems shut off except the drive motor. The LCD on the dash panel will display the full tank icon.

Control Panel Display

The control panel display is a liquid crystal display (LCD) that shows the hour meter, battery charge indicator, solution flow rate and scrub pressure. If the detergent system is enabled, the display will also show the detergent system indicator and the current detergent/solution ratio.

If an A2 Control Board error occurs, the display will show a wrench icon to indicate an error, and display a two-digit error code number. If more than one error exists, the display will sequence through the error codes at one-second intervals. (Refer to the **Control System** section for a list of the A2 Control Board error codes.)

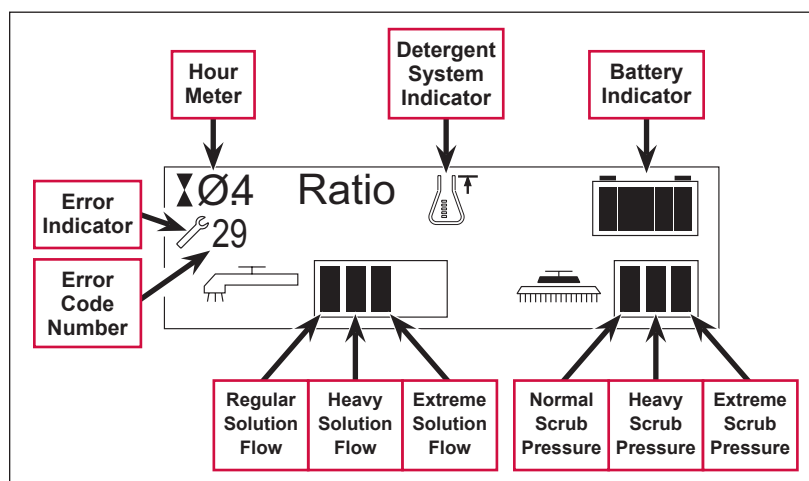

Caution Displays

If the recovery tank is full, the display will show a caution symbol and the tank full icon.

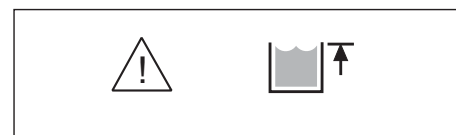

If the battery charge level falls to a critical level, the display will show a caution symbol and the battery-low icon.

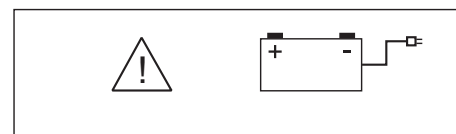

Circuit Breakers

The machine circuit breakers are located on the panel to the left of the Operator seat.



General Maintenance

Maintenance After Use

1. When finished scrubbing, press the Scrub Off Switch. This will automatically raise the scrub deck and squeegee, and switch off the solution, detergent and vacuum systems.
2. Drive the machine to a service area for daily maintenance, and check the machine for any additional maintenance or service that may be needed.
3. To empty and clean the solution tank:
 - a. Remove the **Solution Tank Drain Hose** from its storage clamp.
 - b. Direct the **Solution Tank Drain Hose** to a designated disposal site and remove the **Solution Tank Drain Hose Plug**.
 - c. Rinse the tank with clean water.
4. To empty and clean the recovery tank:
 - a. Pull the **Recovery Tank Drain Hose** from its storage area.
 - b. Direct the **Recovery Tank Drain Hose** to a designated disposal site and remove the **Recovery Tank Drain Hose Plug**. (Hold the end of the **Recovery Tank Drain Hose** above the water level in the tank to avoid sudden, uncontrolled wastewater flow.) The **Recovery Tank Drain Hose** can be squeezed to regulate the flow.
 - c. Rinse the recovery tank with clean water.

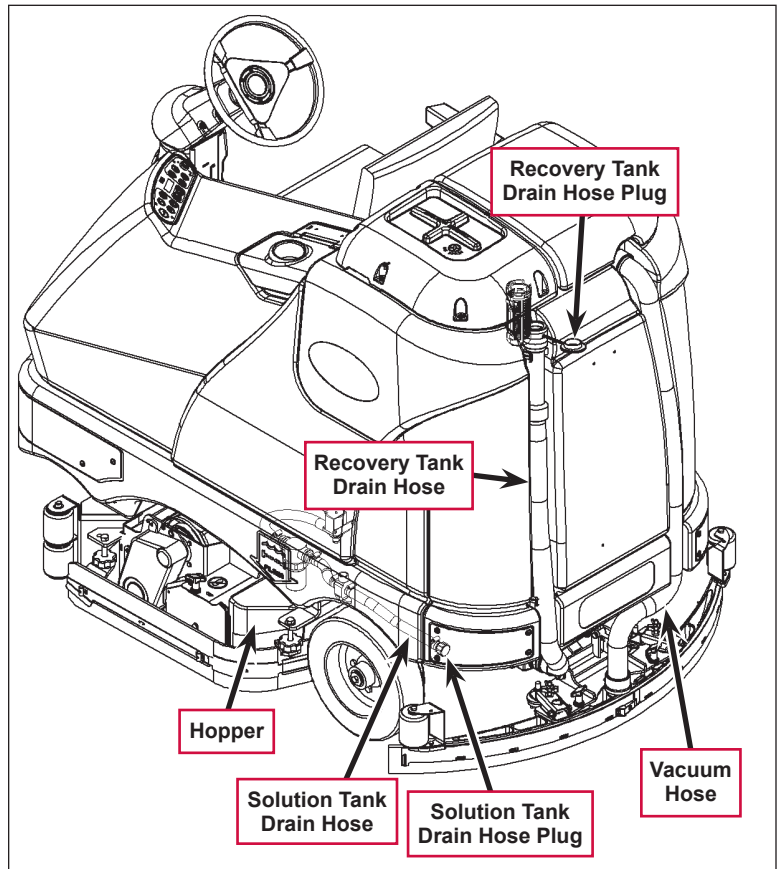

- d. Inspect the **Solution Tank Drain Hose**, **Recovery Tank Drain Hose** and **Vacuum Hose** for wear or damage. Replace the if kinked or damaged.
5. Remove the brushes or pad holders. Rinse the brushes or pads in warm water and hang up to dry.
6. Remove the squeegee, rinse it with warm water, then reinstall.
7. Remove the **Hopper** on cylindrical systems and clean thoroughly. You can remove the **Hopper** from either side of the machine by removing the skirt, tilting the **Hopper** up and away from housing, then pulling the **Hopper** out.
8. Check the following maintenance schedule and perform any required maintenance before you store the machine.

Maintenance Schedule

Maintenance Item	Daily	Weekly	Monthly	Yearly
Charge Batteries	X			
Check/Clean Tanks and Hoses	X			
Check/Clean/Rotate the Brushes/Pads	X			
Check/Clean the Squeegee	X			
Check/Clean Vacuum Shutoff Float	X			
Check/Clean the Vacuum Motor Foam Filter(s)	X			
Clean Hopper on Cylindrical System	X			
Check the Water Level in each Battery Cell		X		
Inspect Scrub Housing Skirts		X		
Inspect and Clean Solution Filter		X		
Check Foot/Parking Brake For Wear and Adjustment		X		
Clean Solution Trough on Cylindrical System		X		
Purge Detergent System		X		
Side Broom Maintenance		X		
Lubrication - Grease Fittings			X	
* Check Carbon Brushes				X

* Inspect the vacuum motor carbon brushes every 300 operating hours. Check the brush and drive motor carbon brushes every 500 operating hours.



Note: Refer to the individual machine sections in this manual for more detail on maintenance and service repairs.

9. Store the machine indoors in a clean, dry place. Keep the machine from freezing. Leave the tanks open to air them out.
10. Turn the key switch off (O) and remove the key.



Caution! Do not pressure-wash the operator control panel, circuit breaker panel or any electrical areas of the machine.

Machine Lubrication

Once a month:

- Pump a small amount of grease into each grease fitting on the machine as shown until grease seeps out around the bearings.
- Apply light machine oil to the components shown.

Apply grease to:

- Squeegee Caster Wheel Axle and Pivot

- Steering Wheel Shaft Universal joint

- Steering Chain

- Squeegee mount angle adjustment knob threads

Apply light machine oil to:

- Squeegee tool end wheels

- Recovery Tank release latch

- Brake Pedal (parking brake) linkage

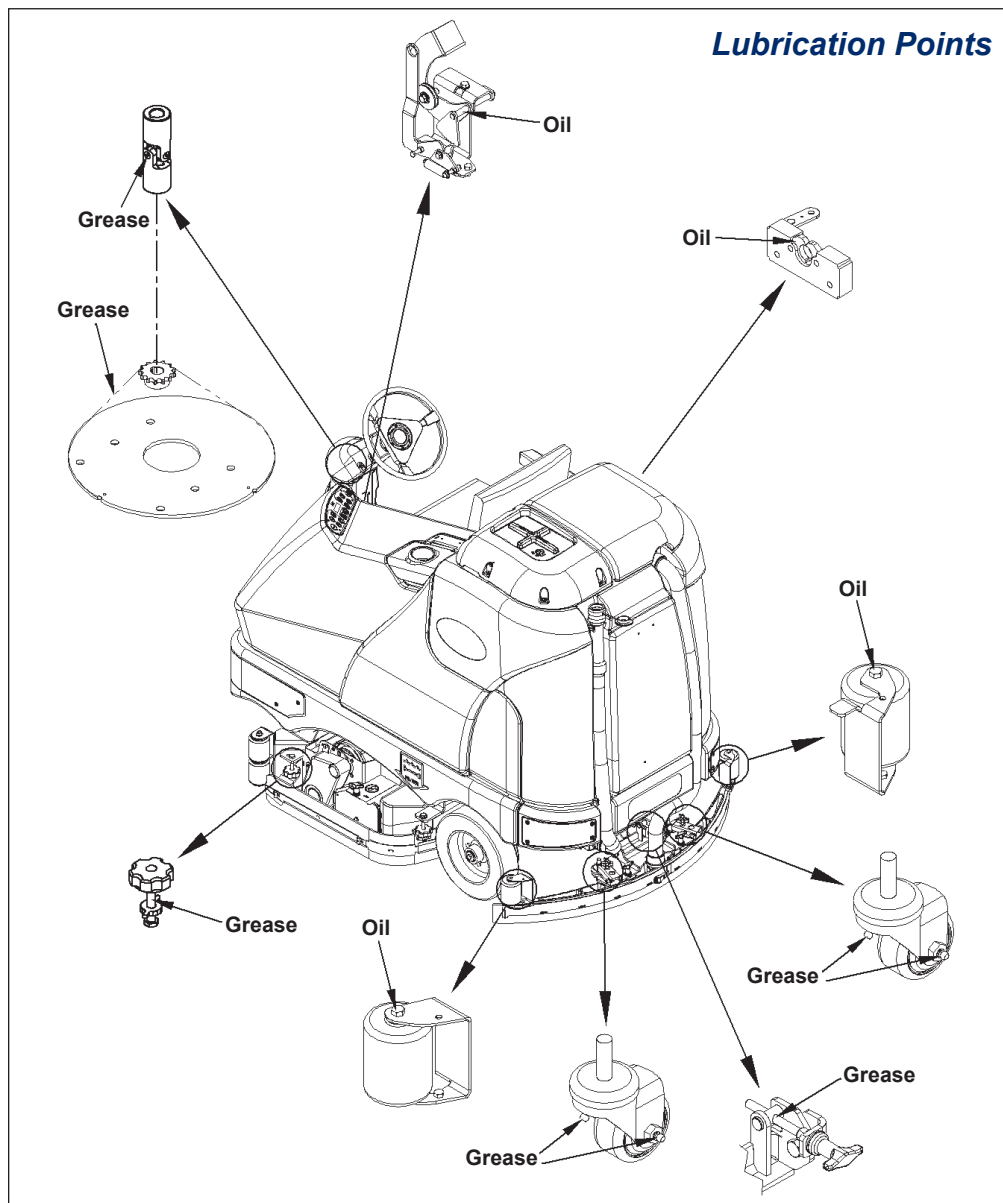

Advance Condor EcoFlex™, Nilfisk BR 1100/1300 EcoFlex™
Disc and Cylindrical
PM Checklist

Customer _____

Address _____

City _____ St _____ Zip _____

Model _____ Serial _____ Hours _____

Defect Codes

- A** needs adjustment
- B** binding
- C** dirty or contaminated
- D** damaged, bent or torn
- L** leaks
- M** missing
- W** worn out

Ref	Operational Inspection Items	OK	Defect Codes (circle)	Does Not Work
1	Steering		A B	
2	Drive Pedal Operation (check for Fwd/Rev drive and any neutral creep)		A B D	
3	Seat Safety Switch (when operator stands up machine is to stop)		A D	
4	Brakes (service and parking)		A B W	
5	Drive System Performance (reference Service Manual for Curtis drive programmer speed changes)		noisy sluggish	
6	Scrub System (Raise/Lower and auto scrubbing functions)		A B	
7	Scrub Brush Pressure Settings (see Service Manual programming, 3 different modes)		A B	
8	Squeegee System (Raise/Lower and auto lift in reverse function)		A B	
9	Vacuum Performance (sealed water lift 70" and 1-inch open hole adapter 15 inches)		C L W	
10	Solution Control (On/Off and flow volume Min/Max)		A B L	
11	Emergency Battery Disconnect Control Lever		B D	
12	Side broom Sweep System, Raise/Lower and auto sweep functions (cylindrical only)		A B D	
13	Tilt Steering Mechanism and Seat		A B D	
14	Optional Accessories (headlight, safety beacon, etc.)		D	
15	Main Control Board Special Program Options (check all applicable program settings, reference Service Manual 56043154); Example, Fault Recall Mode, etc.		Program as needed	
16	Battery Charger Operation		D	
17	Chemical Detergent System Functions		C L	

Ref	Visual Inspection Items	Comments	OK	Defect Codes (circle)	Does Not Work
18	Scrub Brushes, check for wear and rotate			A B D W	
19	Scrub Brush Motor(s) and disc machine gearboxes	Carbon Brushes		B L W	
20	Scrub Brush Drive Belt, wear (cylindrical only)			A D W	
21	Scrub Brush Deck Actuator Motor			A B D W	
22	Brush Driver Plates (flex coupler and retainer clips) (disc only)			D M	
23	Brush Idler Bearing Plate and Driver (cylindrical only)			C W	
24	Scrub Deck Skirts			A B W	
25	Solution Solenoid Valve			C L	
26	Solution Tank, Delivery Hoses and Filter	Clean Filter Screen		C L	
27	Vacuum Motor Carbon Brushes	Wear Limit 3/8"		W	
28	Vacuum Motor Cover Gasket and Filters			L W	
29	Vacuum Float Ball and Cage Assembly	Clean Float		C M	

Chassis System

Major Chassis Components

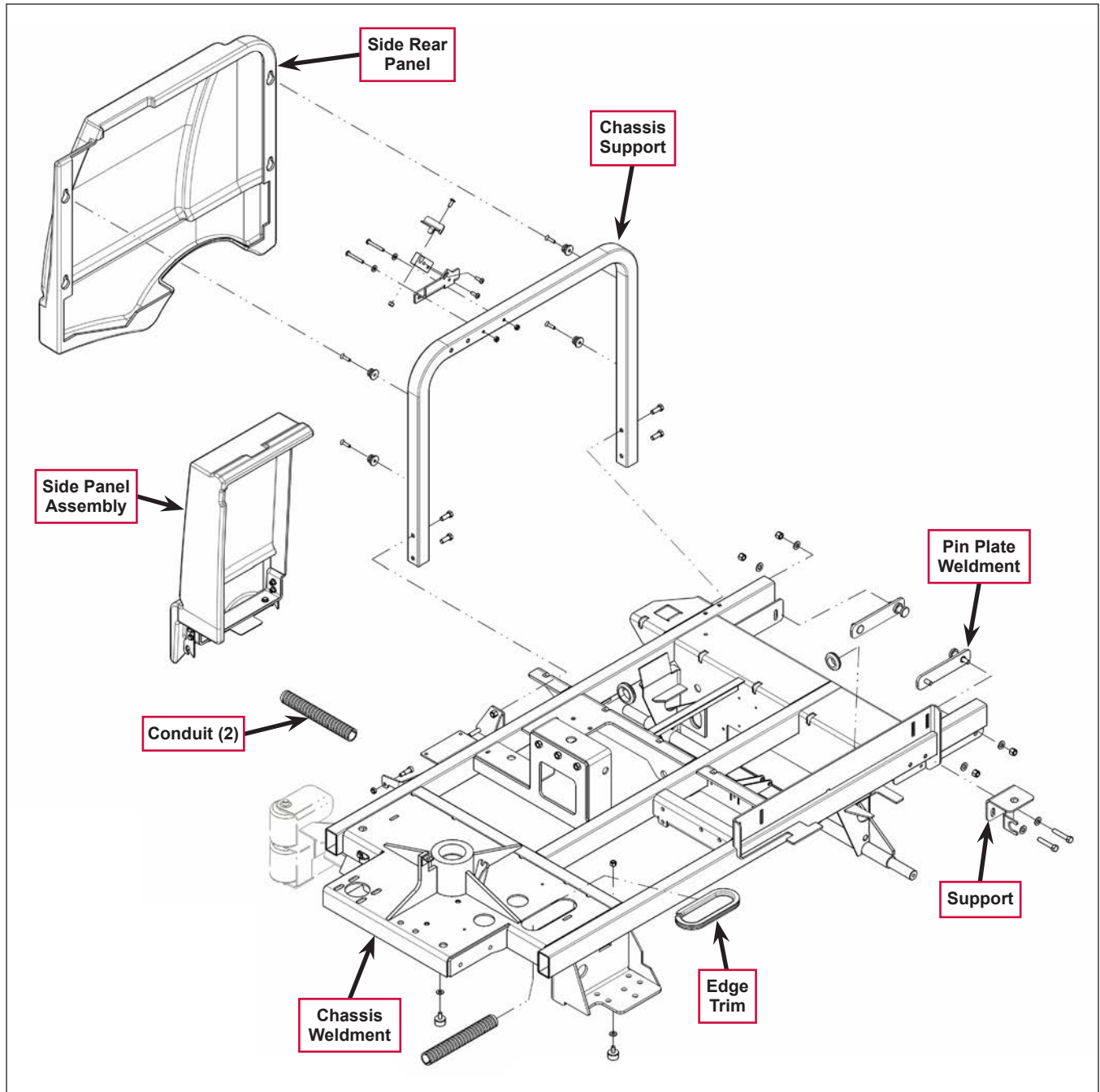

Control System

Functional Description

Overview

The control system consists of the A2 Control Board Assembly, the A3 Switch/Display Panel Assembly and associated sensors and circuitry.

A2 Control Board Assembly

The **A2 Control Board Assembly**, sometimes referred to as the main controller, communicates with the **Curtis A1 Speed Controller** and the A3 Switch/Display Panel Assembly to coordinate the operation of the various machine systems. The **A2 Control Board Assembly** is fastened to the **Electrical Mount** behind the electrical panel cover assembly to the left of the Operator seat.

One primary function of the **A2 Control Board Assembly** is to position the scrub brushes relative to the floor surface using a lift actuator motor. The **A2 Control Board Assembly** continuously monitors the brush motor current draw to maintain the desired scrub pressure on the floor.

- If the brush motor current drops below the desired range, the **A2 Control Board Assembly** switches on the lift actuator motor to move the scrub deck downward until the brush motor current draw is within the correct range for the scrub pressure selected.
- If the brush motor current rises above the desired range, the **A2 Control Board Assembly** switches on the lift actuator motor to lift the scrub deck upward until the brush motor current draw is again within the correct range for the scrub pressure selected.



*Note: Refer to the **Scrub System** section in this manual for a complete explanation of scrub deck operation.*

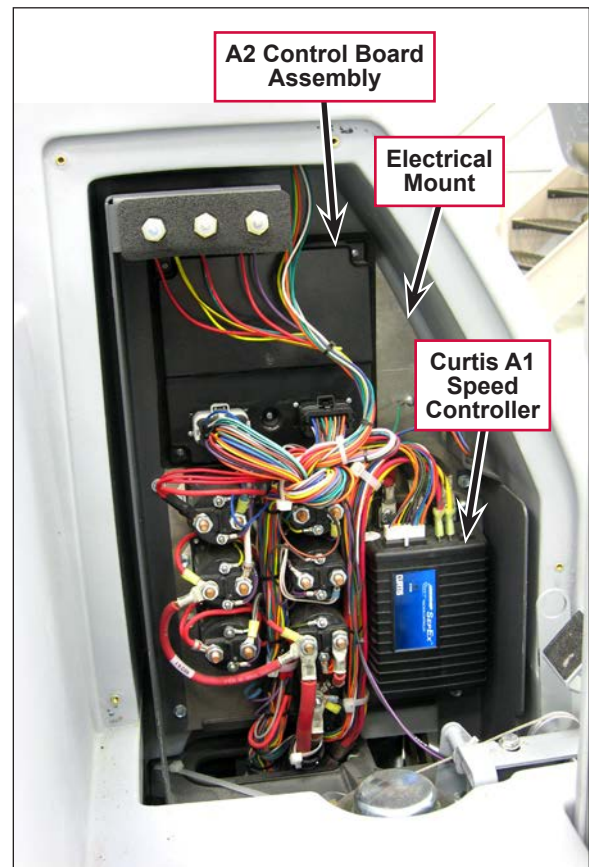

A secondary function of the **A2 Control Board Assembly** is to detect any system failures and display the corresponding error code on the display panel, or store it in the control board's recall memory mode. The error codes are used to help service technicians determine the fault and to guide in repairing a specific system malfunction quickly.



*Note: See the **Troubleshooting** section for further information.*

The **A2 Control Board Assembly** also allows you to change program settings for a set of specific machine functions. See the **Main Control Programming Options** section in this manual for further information.

A3 Switch/Display Panel Assembly

The A3 Switch/Display Panel Assembly is the user interface that includes the various system switches and buttons, and the control panel display. The A3 Switch/Display Panel Assembly sends the operator inputs via a CAN BUS to the A2 Control Board Assembly.



Control System Wiring Diagram

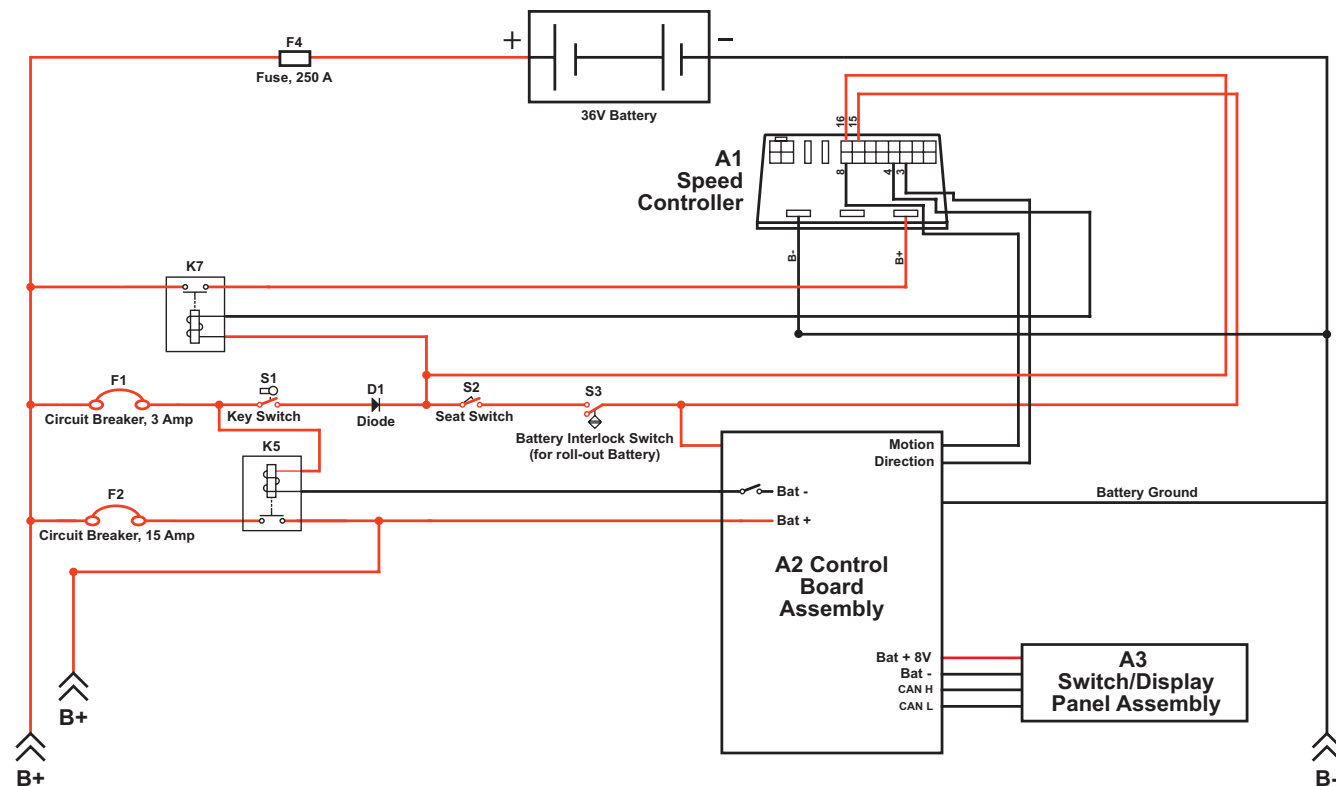

Circuit Description

The A2 Control Board Assembly is connected by several inputs to battery negative:

The A2 Control Board Assembly gets positive battery voltage from two inputs:

- When the key switch, seat switch and battery interlock are closed, positive voltage is supplied to the A2 Control Board Assembly.
- When the key switch is closed, positive voltage is supplied to the coil side of contactor **K5**. When **K5** contacts close, positive voltage is supplied to the A2 Control Board Assembly.

The A3 Switch/Display Panel Assembly gets voltage from two outputs on the A2 Control Board Assembly. The A3 Switch/Display Panel Assembly communicates with the A2 Control Board Assembly via a CAN BUS connection (**CAN H** and **CAN L**).

Main Control Programming Options

Fault Recall Mode

Whenever the A2 Control Board Assembly detects an electrical system error or fault, one or more error codes are displayed and stored by the A2 Control Board Assembly. You can recall error codes (if any) from previous machine operation for troubleshooting purposes. To recall stored error codes:

1. Turn the key switch off.
2. Press and hold the solution switch.
3. While holding the solution switch, turn the key switch on.
4. Continue to hold the solution switch until the solution system indicator turns on.
5. Release the solution switch. The solution system indicator turns off and the scrub off indicator will light. The display will show a wrench icon indicating that you are in fault recall mode.
 - If there are no previous error codes stored, the display will show the no-fault wrench icon  asking you to reset the machine (no fault). Skip to step 7.
 - If error codes have been stored, the display will show the wrench icon and error number(s) next to the wrench. If more than one error code is stored, the display will toggle through all the errors stored.
6.
 - If you want to save the codes, skip to step 7.
 - To clear the stored error codes, press the scrub off switch. The display will now show key switch icon asking you to reset the machine.
7. To exit the fault recall mode, turn the key switch off.

To Select the Battery Used in the Machine

Note that the factory default is Standard (LVC = 31V)

1. Turn the key switch off.
2. Press and hold the scrub off switch.
3. While holding the scrub off switch, turn the key switch on.
4. Continue to hold the scrub off switch until the Scrub Off LED indicator turns on.
5. Release the switch. The display will now show BATTERY.
6. Press the scrub on switch to select the type of battery that is in the machine.
7. Press the scrub off switch to save the new setting and display the key switch icon.
8. Turn the key switch off. The new setting will be saved until changed again.

To Restore the Scrub Pressures to the Factory Default Settings

1. Turn the key switch off.
2. Press and hold the scrub on switch.
3. While holding the scrub on switch, turn the key switch on.

4. Continue to hold the scrub on switch until the display shows key switch icon. The factory default scrub pressures have now been restored.
5. Turn the key switch off.

To Enable/Disable the Fault Detection

Note that the factory default for fault detection is ON.

Normally the main control unit will perform checks of the electrical system during operation. If a fault occurs in a particular system, that system (and possibly others) will be shut down. This can make troubleshooting the system difficult. This option will allow service personnel to disable some of the fault detection checks to facilitate troubleshooting. This will not disable the over-current protection on any of the systems. To turn the fault checking on or off:

1. Turn the key switch off.
2. Press and hold both the scrub off switch and solution switch.
3. While holding both switches, turn the key switch on.
4. Continue to hold both switches until both switch indicators turn on. The display will show a wrench icon indicating fault detection mode.
5. Release both switches. The solution system indicator light will blink and the scrub off indicator will stay on.
6. Press the solution switch to toggle the fault detection between enabled/on (wrench icon with no cross) or disabled/off (wrench icon with cross).
7. Press the scrub off switch to save the new setting and display the key switch icon.
8. Turn the key switch off. The new setting will be saved until changed again.

To Display the Control Board Revision Level

1. Turn the key switch off.
2. Press and hold both the scrub off switch and traction control switch.
3. While holding both switches, turn the key switch on.
4. Continue to hold both switches until the scrub off and traction control indicators light.
5. Release both switches. The scrub off and traction control indicators will switch off. The display will show the **MAIN REVISION** of the A2 control board assembly, the **DISPLAY REVISION** of the A3 switch/display panel assembly and the key switch icon.
6. Turn the key switch off.

Monitor Mode

The control system allows the five machine settings listed below to be quickly checked in the monitor mode to view the machine's specific setup. To enter the monitor mode and view the current machine settings:

1. Turn the key switch off.
2. Press and hold the detergent switch.

3. While holding the detergent switch, turn the key switch on.
4. Continue to hold the detergent switch until the detergent system indicator switches on.
5. Release the detergent switch. The display will show the following current machine programmed settings:
 - Scrub deck type and size,
 - Detergent mode on/off,
 - Fault detection on/off,
 - Vacuum motor selection – **VACUUM-SINGLE** (one motor) or **VACUUM-DUAL** (two motors).
6. To exit the monitor mode, turn the key switch off.



Scrub Deck Down Time Adjustment

Note that the factory default deck down time is two seconds.

When scrub on switch is pressed, the control board will automatically lower the deck for two seconds. The time that the deck is lowered is adjustable from one second to three seconds in 0.1-second increments.

To adjust the scrub deck down time:

1. Turn the key switch off.
2. Press and hold the scrub on and solution switches.
3. While holding both switches, turn the key switch on.
4. Continue to hold both switches until both switch indicators turn on.
5. Release both switches. The display will now show a clock icon in the upper left corner with a number indicating the scrub deck down time period.
6. Press the scrub on switch to increment the time period. Each press of the switch increments the scrub deck down time 0.1 seconds. For example, the time will increment from 2.0 seconds to 2.1 seconds, and so on. The deck down times range from 1.0 to 3.0 seconds.
7. Press the scrub off switch to save the new setting and display the key switch icon.
8. Turn the key switch off. The new setting will be saved until changed again.

Normal (Light) Scrub Setting Adjustment

Note that the factory default settings for the normal scrub setting are: Scrub pressure – one bar, Solution flow rate – one bar.

The scrub pressure and solution flow rate for the normal scrub setting can be programmed to better suit a particular application. This allows you to select a higher solution flow rate with normal scrub pressure, or a normal solution rate with heavier scrub pressure, etc., as the normal scrub setting. To change the normal scrub settings:

1. Turn the key switch off.
2. Press and hold the scrub on and scrub speed switches.

3. While holding both switches, turn the key switch on.
4. Continue to hold both switches until the scrub speed indicator turns on and the normal scrub on indicator blinks.
5. Release both switches. The display will now show a scrub icon (either disc or cylindrical) with the current scrub pressure setting.
6. Press the scrub on switch to increment the scrub pressure setting as shown by the number of bars in the display.
7. Press the scrub off switch to save the new scrub pressure setting and move to the solution flow rate setting. The display will now show the solution icon with gauge. The normal scrub indicator will stop blinking and the solution system indicator will blink.
8. Press the solution switch to increment the solution flow rate as shown by the number of bars in the display.
9. Press the scrub off switch to save the new solution flow rate setting and move to the detergent concentration setting. The display will now show the detergent icon with a **0**, **+** or **-** next to it. The solution system indicator will stop blinking and the detergent indicator will blink.
10. Press the detergent switch to scroll through and select the **0**, **+** or **-** character in the display.
 - Selecting **0** will not change the detergent concentration in the detergent ratios.
 - Selecting **+** will increase the detergent concentration in the detergent ratios by 10 percent.
 - Selecting **-** will decrease the detergent concentration in the detergent ratios by 10 percent.
11. Press the scrub off switch to save the detergent concentration setting and display the key switch icon.
12. Turn the key switch off. The new settings will be saved until changed again.

Heavy Scrub Setting Adjustment

Note that the factory default settings for the heavy scrub setting are: Scrub pressure – two bars, Solution flow rate – two bars.

The scrub pressure and solution flow rate for the heavy scrub setting can be programmed to better suit a particular application. This allows you to select a higher solution rate with heavy scrub pressure, or a normal solution rate with heavy scrub pressure, etc., as the heavy scrub setting. To change the heavy scrub settings:

1. Turn the key switch off.
2. Press and hold the scrub on and detergent switches.
3. While holding both switches, turn the key switch on.
4. Continue to hold both switches until the detergent indicator turns on and the heavy scrub indicator blinks.
5. Release both switches. The display will now show a scrub icon (either disc or cylindrical) with the current scrub pressure setting.
6. Press the scrub on switch to increment the scrub pressure setting as shown by the number of bars in the display.
7. Press the scrub off switch to save the new scrub pressure setting and move to the solution flow rate setting. The display will now show the solution icon with gauge. The solution system indicator will blink.

8. Press the solution switch to increment the solution flow rate as shown by the number of bars in the display.
9. Press the scrub off switch to save the new solution flow rate setting and move to the detergent concentration setting. The display will now show the detergent icon with a **0**, **+** or **-** next to it. The solution system indicator will stop blinking and the detergent indicator will blink.
10. Press the detergent switch to scroll through and select the **0**, **+** or **-** character in the display.
 - Selecting **0** will not change the detergent concentration in the detergent ratios.
 - Selecting **+** will increase the detergent concentration in the detergent ratios by 10 percent.
 - Selecting **-** will decrease the detergent concentration in the detergent ratios by 10 percent.
11. Press the scrub off switch to save the detergent concentration setting and display the key switch icon.
12. Turn the key switch off. The new settings will be saved until changed again.

Extreme Scrub Setting Adjustment

Note that the factory default settings for the extreme scrub setting are: Scrub pressure – three bars, Solution flow rate – three bars.

The scrub pressure and solution flow rate for the extreme scrub setting can be programmed to better suit a particular application. This allows you to select a higher solution rate with extreme scrub pressure, or a normal solution rate with extreme scrub pressure, etc., as the extreme scrub setting. To change the extreme scrub settings:

1. Turn the key switch off.
2. Press and hold the scrub on and vacuum/wand switches.
3. While holding both switches, turn the key switch on.
4. Continue to hold both switches until the vacuum/wand indicator turns on, and the normal and heavy scrub indicators blink.
5. Release both switches. The display will now show a scrub icon (either disc or cylindrical) with the current scrub pressure setting.
6. Press the scrub on switch to increment the scrub pressure setting as shown by the number of bars in the display.
7. Press the scrub off switch to save the new setting and move to the solution flow rate setting. The display will now show the solution icon with gauge. The normal and heavy scrub indicators will stop blinking and the solution indicator will blink.
8. Press the solution switch to increment the solution flow rate as shown by the number of bars in the display.
9. Press the scrub off switch to save the new solution flow rate setting and move to the detergent

concentration setting. The display will now show the detergent icon with a **0**, **+** or **-** next to it. The solution system indicator will stop blinking and the detergent indicator will blink.

10. Press the detergent switch to scroll through and select the **0**, **+** or **-** character in the display.
 - Selecting **0** will not change the detergent concentration in the detergent ratios.
 - Selecting **+** will increase the detergent concentration in the detergent ratios by 10 percent.
 - Selecting **-** will decrease the detergent concentration in the detergent ratios by 10 percent.
11. Press the scrub off switch to save the detergent concentration setting and display the key switch icon.
12. Turn the key switch off. The new settings will be saved until changed again.

Scrub Speed Switch Lockout

Note that the factory default setting for the scrub speed switch is **FAST/SLOW - ENABLE**.

The control system is programmed to limit the maximum travel speed while scrubbing to a value less than that allowed when driving and not scrubbing. Pressing the scrub speed switch on the control panel will override this speed limiting feature and allow scrubbing at a the higher speed. If you wish to prevent scrubbing at this faster speed, you can disable the scrub speed switch override feature. To disable the scrub speed switch override feature:

1. Turn the key switch off.
2. Press and hold the scrub speed switch.
3. While holding the scrub speed switch, turn the key switch on.
4. Continue to hold the scrub speed switch until the scrub speed and scrub off indicators both turn on.
5. Release the scrub speed switch. The scrub speed indicator light will blink.
6. Press the scrub speed switch to enable or disable the scrub speed switch override feature. **FAST/SLOW - ENABLE** means that the high-speed scrub feature is turned on. **FAST/SLOW - DISABLE** means that the high-speed scrub feature is turned off.
7. Press the scrub off switch to save the setting and display the key switch icon.
8. Turn the key switch off. The new setting will be saved until changed again.

Detergent System Selection Mode

1. Turn the key switch off.
2. Press and hold the scrub off switch and the detergent switch.
3. While holding both switches, turn the key switch on.
4. Continue to hold both switches until both switch indicators turn on.
5. Release both switches. The scrub off indicator will stay lit and the detergent system indicator will blink. The display will now show a detergent bottle in the upper left corner indicating the detergent selection mode.
6. Press the detergent switch to select between a normal detergent bottle icon indicating that the detergent system is activated, or a detergent bottle with a cross through it indicating that the detergent system is

not activated.

7. Press the scrub off switch to save the new setting and display the key switch icon.
8. Turn the key switch off. The new setting will be saved until changed again.

EcoFlex™ Mode Selection

Note that the factory default setting for the EcoFlex™ Mode is **OFF**.

1. Turn the key switch off.
2. Press and hold the EcoFlex™ button.
3. While holding the button, turn the key switch on.
4. Continue to hold the button for two seconds until the EcoFlex™ and scrub off indicators turn on.
5. Release the EcoFlex™ button. The display will now show the **ECOFLEX MODE/ OFF**, **ECOFLEX MODE/MODE 1** and **ECOFLEX MODE/MODE 2** menu.
6. Press the EcoFlex™ button to scroll through the menu and select the desired **ECOFLEX MODE**.
7. Press the scrub off switch to save the setting and display the key switch icon.
8. Turn the key switch off. The new setting will be saved until changed again.

ECOFLEX MODE OFF
ECOFLEX MODE MODE 1
ECOFLEX MODE MODE 2

Vacuum Motor Configuration Option

Note that the factory default setting for the vacuum motor configuration is **SINGLE** (one vacuum motor).

All rider scrubber models covered in this manual can be equipped with optional dual vacuum motors. The A1 control board assembly must be programmed for the number of vacuum motors installed so that the current overload protection will function correctly. To select the vacuum motor configuration:

1. Turn the key switch off.
2. Press and hold the scrub system off and vacuum/wand switches.
3. While holding both switches, turn the key switch on until the scrub off and vacuum/wand indicators light.
4. Release both switches. The vacuum/wand indicator will flash. The control panel display will now indicate the vacuum motor setting.
5. Press the vacuum/wand switch to toggle between **VACUUM - SINGLE** for a single vacuum motor or **VACUUM - DUAL** for two vacuum motors.
6. Press the scrub off switch to save the setting and display the key switch icon.
7. Turn the key switch off. The new setting will be saved until changed again.

Recovery Tank Full Detection Enable/Disable

Note that the factory default setting for the recovery tank full detection is **ENABLE**.

The Condor is equipped with a feature that will automatically shut off the vacuum and scrub systems

and display a recovery tank full icon on the control panel display when the recovery tank becomes full. If problems are encountered with the vacuum shutoff feature, such as the vacuum shutting off even when the recovery tank is not full, this feature can be turned off. To turn this feature on (enable) or off (disable):

1. Turn the key switch off.
2. Press and hold the vacuum/wand switch.
3. While holding the vacuum/wand switch, turn the key switch on.
4. Continue to hold the vacuum/wand switch until the vacuum/wand indicator turns on.
5. Release the vacuum/wand switch. The vacuum/wand indicator will blink and the scrub off indicator will turn on. The display will now show a text message **REC TANK FULL DETECT/ENABLE** or **DISABLE**.
6. Press the vacuum/wand switch to toggle between **ENABLE** or **DISABLE**. **ENABLE** means that the automatic shutoff feature is turned on. **DISABLE** means that the automatic shutoff feature is turned off.
7. Press the scrub off switch to save the setting and display the key switch icon.
8. Turn the key switch off. The new setting will be saved until changed again.

Solution Flow in Reverse Enable/Disable

Note that the factory default setting for the solution flow in reverse option is **ENABLE**.

The solution flow is programmed to dispense solution when the machine backing up. To disable solution flow when the machine moves in reverse:

1. Turn the key switch off.
2. Press and hold the EcoFlex™ button and the solution switch.
3. While holding both the button and switch, turn the key switch on.
4. Continue to hold the button and switch until the solution system and vacuum/wand indicators turn on.
5. Release the button and switch. The vacuum/wand indicator will turn off, the solution system indicator will blink and the scrub off indicator will turn on. The display will now show the message **SOLUTION IN REVERSE/ENABLE** or **DISABLE**.
6. Press the solution switch to toggle between **SOLUTION IN REVERSE ENABLE** or **DISABLE**. If you select **ENABLE**, the solution flow will stay on when the machine is moving in reverse. If you select **DISABLE**, solution flow will stop when the machine is moving in reverse.
7. Press the scrub off switch to save the setting and display the key switch icon.
8. Turn the key switch off. The new setting will be saved until changed again.

Indicator LED Intensity Selection Option

Note that the factory default setting for the indicator LED intensity is normal.

To change the intensity of the LEDs in the control panel indicators.

1. Turn the key switch off.

2. Press and hold the vacuum/wand and scrub speed switches.
3. While holding both switches, turn the key switch on.
4. Continue to hold both switches until the vacuum/wand and scrub speed indicators turn on. The display will now show a light bulb icon in the upper left corner indicating the LED light intensity selection.
5. Release both switches. The scrub speed and scrub off indicators will light and the vacuum/wand indicator will blink.
6. Press the vacuum/wand switch to select between the normal intensity or extra bright intensity levels.
7. Press the scrub off switch to save the setting and display the key switch icon.
8. Turn the key switch off. The new setting will be saved until changed again.

Detergent and Solution Pump Purge

The EcoFlex™ detergent system has two purge (flush) programs to ensure that the detergent delivery hoses and related components are kept open and clean. A general operational description in how the system functions is found in the **Solution System** section. To activate the maintenance purge functions:

Method 1

1. Turn the key switch off.
2. Press and hold both the detergent and solution switches.
3. While holding the switches, turn the key switch on. The display will show the purge icon, the detergent and solution pumps will run for approximately 20 seconds, then the pumps will shut off.
4. When the purge cycle is complete, turn the key switch off.

Method 2 (as described in the Instructions for Use)

1. Turn the key switch on.
2. Press and hold both the detergent and solution switches for three seconds. The detergent and solution pumps will run for approximately 10 seconds.
3. When the purge cycle is complete, turn the key switch off.

Side Broom Function

1. Turn the key switch off.
2. Press and hold the side broom on/down switch.
3. While holding the switch, turn the key switch on.
4. Continue to hold the switch until the side broom on/down indicator turns on.
5. Release the switch. The display will now show **SIDE BROOM/ENABLE** or **DISABLE**.
6. Press the side broom on/down switch to toggle between **SIDE BROOM ENABLE** or **SIDE BROOM DISABLE**.
7. Press the scrub off switch to save the setting and display the key switch icon.

- Turn the key switch off. The new setting will be saved until changed again.

Side Broom Height Adjustment

The height of the side brooms is determined by the length of time the side broom actuator runs as it lowers the side brooms. Note that:

- Increasing the side broom actuator run time lowers the side broom height.
- Decreasing the side broom actuator run time raises the side broom height.

To adjust the side broom height:

- Turn the key switch off.
- Press and hold the side broom on/down and scrub off switches.
- While holding the switches, turn the key switch on.
- Continue to hold the switches until the side broom on/down indicator, scrub off indicator and both scrub on indicators turn on.
- Release the switches. The indicators will stay on and the display will now show the side broom actuator down run time in seconds.
- Press the scrub on switch to increase the side broom actuator run time and lower the position of side brooms.
 - Press the side broom on/down switch to decrease the side broom actuator run time and raise the position of side brooms.

Note that the side broom actuator run times range from 1.0 to 3.0 seconds.

- Press the scrub off switch to save the side broom height. The actuator will raise the brooms to their up position and the display will show a key switch icon.
- Turn the key switch off. The machine is now reprogrammed to work with the new side broom height setting.

Display Mode Selection

- Turn the key switch off.
- Press and hold the detergent switch and EcoFlex™ button.
- While holding the detergent switch and EcoFlex™ button, turn the key switch on.
- Continue to hold the button and switch for two seconds until the EcoFlex™ and detergent system indicators turn on.
- Release the button and switch. The EcoFlex™ indicator will blink and the display will show **DISPLAY MODE**.
- Press the EcoFlex™ button to toggle between **1. US DISPLAY** and **2. GLOBAL DISPLAY**.
- Press the scrub off switch to save the new setting and display the key switch icon.
- Turn the key switch off. The new setting will be saved until changed again.

Service Test Mode

The purpose of the service test mode is to assist the service technician with numerous quick shortcut troubleshooting procedures. The service test mode allows you to control individual system components independent of the normal machine operator inputs.

To Enter the Service Test Mode

1. Turn the key switch off.
2. Press and hold the scrub speed and traction control switches.
3. While holding the scrub speed and traction control switches, turn the key switch on.
4. Continue to hold the scrub speed and traction control switches until the traction control indicator lights.
5. Release the scrub speed and traction control switches. The scrub speed indicator will turn off and the display will show **NEUTRAL/SC-NO FAULT** (speed controller - no fault). The display, switch and indicator functions in the service test mode are described below.
6. To exit the service test mode, turn the key switch off.

Service Test Mode Display

- **Speed Control Status**

- This indicator will read **SC-NO FAULT** (speed controller - no fault) if the status signal from the speed control is normal.
- If a speed control fault exists, this indicator will read **SC-FAULT** (speed control fault). Refer to the **Wheel System, Traction** section for details on these codes.

- **Speed Control Foot Throttle Status**

- The control panel display will read **NEUTRAL** when the operator foot pedal is at rest.
- The control panel display will read **FORWARD** when the foot pedal is depressed in the forward direction to activate its forward drive mode functions.
- The control panel display will read **REVERSE** when the operator foot pedal is depressed in the reverse direction to activate its reverse drive mode functions.

Control Panel Switch and Button Functions

- **Scrub System Off Switch** – This switch controls the scrub brush motor(s). Pressing and releasing this switch will alternately turn the brush motor(s) on and off. The scrub off indicator provides the following status information:

- Off - Brush motor output is off and there is no brush motor current sensed.
- Steady Blue - Brush motor output is on and there is normal brush motor current sensed.



- **Scrub ON/Pressure Select Switch** – This switch controls the scrub deck lift actuator as follows:



- Pressing the switch the first time will switch on the actuator to lower the scrub deck. The normal scrub indicator (left blue LED) will light as the actuator is running. Once the deck reaches the down position, the normal scrub indicator will blink.
- Pressing the switch a second time will switch off the normal scrub indicator.
- Pressing the switch a third time will switch on the actuator to raise the scrub deck. The normal scrub indicator will light as the actuator is running. Once the deck reaches the up position, the normal scrub indicator will blink.
- Pressing the switch a fourth time will switch off the normal scrub indicator.

- **Vacuum/Wand Switch** – This switch controls the squeegee lift actuator and vacuum motor(s) as follows:

- Pressing the switch the first time will switch on vacuum motor(s) and switch on the actuator to lower the squeegee. The vacuum/wand indicator will light as the actuator is running. Once the squeegee reaches the down position, the vacuum/wand indicator will blink.
- Pressing the switch a second time will switch off the vacuum/wand indicator.
- Pressing the switch a third time will switch off the vacuum motor(s) and switch on the actuator to raise the squeegee. The vacuum/wand indicator will light as the actuator is running. Once the squeegee reaches the up position, the vacuum/wand indicator will blink.
- Pressing the switch a fourth time will switch off the vacuum/wand indicator.



- **Side Broom On/Down Switch** – This switch controls the side broom motors and side broom lift actuator as follows:

- Pressing the switch the first time will switch on side broom motors and switch on the actuator to lower the side brooms. The side broom on/down indicator will light as the actuator is running. Once the side brooms reach the down position, the side broom on/down indicator will blink.
- Pressing the switch a second time will switch off the side broom on/down indicator.
- Pressing the switch a third time will switch off the side broom motors and switch on the actuator to raise the side brooms. The side broom on/down indicator will light as the actuator is running. Once the side brooms reach the up position, the side broom on/down indicator will blink.
- Pressing the switch a fourth time will switch off the side broom on/down indicator.



- **Solution Switch** – This switch controls the solution solenoid and solution control pump. Pressing and releasing this switch will alternately turn the solution solenoid and solution pump on and off. The solution system indicator provides the following status information:

- Off – Solenoid and solution pump outputs are off.



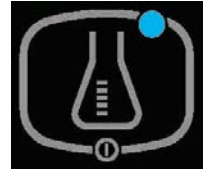

- Steady Blue – Solenoid and solution pump outputs are on.
- **Detergent Switch** – This switch controls the detergent pumps. Pressing and releasing this switch will alternately turn the detergent pumps on and off. The detergent system indicator provides the following status information:
 - Off – Detergent pump output is off.
 - Steady Blue – Detergent pump output is on.







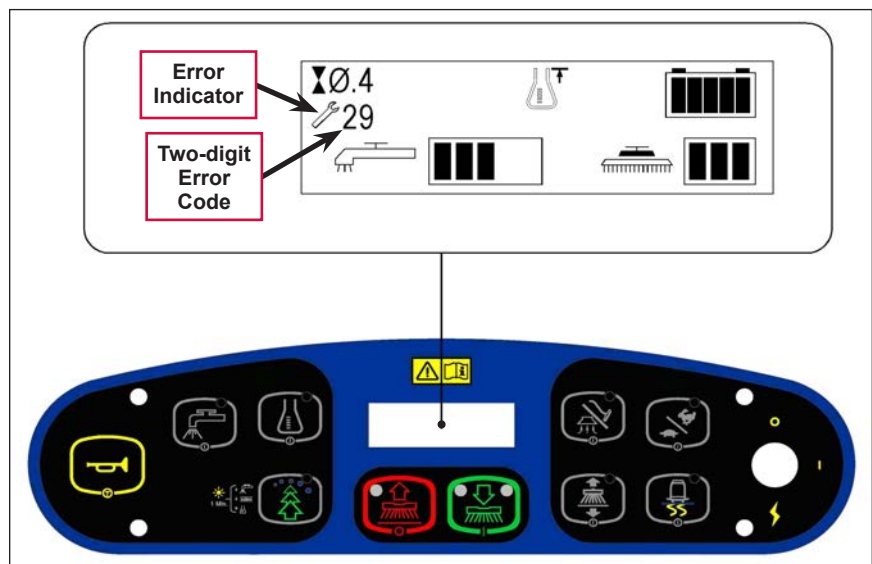

Troubleshooting









Error Indicator and Error Code Display









Any error codes detected by A2 Control Board Assembly will be displayed on the control panel display as they occur. If more than one error exists, the display will sequence through the error codes at one-second intervals. The error will display as a mechanical wrench symbol  followed by a two-digit code. For example,  29 as shown in the adjacent drawing would be an open vacuum motor error.

















Error Codes

Display Code	Error/Fault Description	Correction
 01	Scrub deck sense R2 resistor fault	A fault will occur if scrub deck sensor resistor is unplugged or damaged. Check the resistor wiring for an open and substitute a new resistor and test scrub deck for correct operation. Note that there are four different resistor values used on the different deck types. See the electrical diagram decal for the correct specification for the resistor to replace.
 03	Speed control fault	Observe the blue flashing light detergent indicator light, then refer to the Wheel Drive, Traction section to troubleshoot the drive system.
 04	Scrub motor overload Note that some models use one, two or three scrub motors. Refer to the Specifications section for detailed load current values for the different decks.	<ol style="list-style-type: none"> 1. Check for binding in the rotation of the brushes and incorrect brush deck lift actuator operation. 2. Check the negative supply cable at the brush motor for a wiring problem, and also the small BRN current sense wire in the harness and A2 pin J2-2. 3. Check for a short circuit* in the brush motor or wiring. On cylindrical models check for excessive belt tension and the condition of the idler bearing.
 05	Left brush motor contactor coil overload Contactor K4 is for the left motor on the three-motor decks. The nominal coil resistance is 94 ohms for all three motor contactors.	<ol style="list-style-type: none"> 1. Check for a K4 coil wiring problem or a short circuit* (wire colors VIO and GRA/RED). 2. Check the coil resistance. If the resistance is below 75 ohms, replace the coil.
 06	Center brush motor contactor coil overload Contactor K3 is for the center motor on three-motor decks. K3 is for the left motor on two-motor decks.	<ol style="list-style-type: none"> 1. Check for a K3 coil wiring problem or a short circuit* (wire colors VIO and WHT/VIO). 2. Check the coil resistance. If the resistance is below 75 ohms, replace the coil.
 07	Right brush motor contactor coil overload Contactor K2 is for the right motor on two- or three-motor decks. K2 is the only contactor on a single-motor decks.	<ol style="list-style-type: none"> 1. Check for a K2 coil wiring problem or a short circuit* (wire colors VIO & YEL/BLU). 2. Check the coil resistance. If the resistance is below 75 ohms, replace the coil.
 08	Scrub deck actuator overload <ul style="list-style-type: none"> • Normal current load is 1-3 amps. • Max current load is 6 amps. • Max current with no load is 1.4 amps. 	<ol style="list-style-type: none"> 1. Check for binding or a frozen brush lift linkage and excessive weight on the brush deck. 2. Check for a short circuit* in the actuator motor and wiring. Repair or replace. <p>To test the actuator, disconnect the motor plug and attach the actuator power cord adapter (p/n 56407502) and perform an amp draw test. Compare readings to the current load specifications.</p>

Display Code	Error/Fault Description	Correction
 09	Vacuum motor overload Normal current load for one motor is 16-20 amps. Normal current load for two motors is 32-40 amps.	<ol style="list-style-type: none"> 1. Check for debris in the vacuum motor(s). 2. Check for worn carbon brushes - replace brushes. 3. Defective motor bearings - repair or replace. 4. Check for a short circuit* in the vacuum motor or wiring - repair or replace.
 10	K1 Vacuum motor contactor coil overload. The nominal coil resistance is 100 ohms.	<ol style="list-style-type: none"> 1. Check for a K1 coil wiring problem or short circuit* (wire colors VIO and BLU). 2. Check the coil resistance. If the coil resistance is below 80 ohms, replace the coil.
 11	Squeegee actuator overload <ul style="list-style-type: none"> • Normal current load is 1-2 amps. • Max current load is 6 amps. • Max current with no load is 1.4 amps. 	<ol style="list-style-type: none"> 1. Check for binding or frozen squeegee lift linkage and excessive weight on the squeegee mount. 2. Check for a short circuit* in the actuator motor and wiring. Repair or replace. <p>To test the actuator, disconnect the motor plug and attach the actuator power cord adapter (p/n 56407502) and perform an amp draw test. Compare readings to the current load specifications.</p>
 12	L1 Solution solenoid overload The nominal coil resistance is 74 ohms.	<ol style="list-style-type: none"> 1. Check for a wiring problem or short circuit*. 2. Check the coil resistance. Replace the solution solenoid if the coil resistance is lower than 58 ohms.
 13	Solution control pump overload <ul style="list-style-type: none"> • The normal current load is 0.8-1.8 amps. • A current load of 3.2 amps or over will generate code 13 pump motor overload. 	<ol style="list-style-type: none"> 1. Check for short circuits* in the wiring and in the M12 pump motor. 2. Disconnect the solution pump motor and run the machine to see if the wiring is shorted. 3. Check the current draw and compare to the specifications. If the motor shows high current draw replace the motor.
 16	K6 Side broom motor contactor coil overload The nominal coil resistance is 100 ohms.	<ol style="list-style-type: none"> 1. Check for a K6 coil wiring problem or short circuit* (wire colors VIO and BRN/BLK). 2. Check the coil resistance. If the resistance is below 80 ohms, replace the contactor.
 17	Side broom actuator overload <ul style="list-style-type: none"> • Normal current load is 1-2 amps. • Max current load is 6 amps. • Max current with no load is 1.4 amps. 	<ol style="list-style-type: none"> 1. Check for binding or frozen side broom lift linkage and excessive weight on the lifting arms. 2. Check for a short circuit* in the actuator motor and wiring. Repair or replace. <p>To test the actuator, disconnect the motor plug and attach the actuator power cord adapter (p/n 56407502) and perform an amp draw test. Compare readings to the current load specifications.</p>
 18	K5 Auxiliary contactor coil overload The nominal coil resistance is 100 ohms.	<ol style="list-style-type: none"> 1. Check for a K5 coil wiring problem or short circuit* (wire colors YEL/BRN & BLK/ORN). 2. Check the coil resistance. If the resistance is below 80 ohms, replace the contactor.

Display Code	Error/Fault Description	Correction
 19	Back-up alarm overload Specifications: <ul style="list-style-type: none"> • 5-15 VDC • Current load 100 ma 	<ol style="list-style-type: none"> 1. Check for a back-up alarm wiring problem or short circuit* (wire colors: positive ORN/BRN; negative BLU/WHT). 2. Disconnect the back-up alarm and test to see if the wiring is shorted. If not, replace the back-up alarm.
 20	Horn output fault Current load spec. 1.2 amps	<ol style="list-style-type: none"> 1. The horn or horn wiring's +36V power feed is shorted to ground (wire colors VIO and BLU/RED). 2. Disconnect the horn and test to see if the wiring is shorted. If not, replace the horn.
 21	Scrub motor open	<ol style="list-style-type: none"> 1. Check for an open circuit in the motor wiring or for a defective motor. 2. Check for 36 volts at the scrub motor that is not running. If you get 0 Volts, replace the brush motor contactor.
 22	Left brush motor contactor coil open	<ol style="list-style-type: none"> 1. Check for an open circuit in the K4 coil and wiring (wire colors VIO and GRA/RED). 2. Test for 36V at the K4 coil. If you get 0 Volts, check the A2 control board assembly.
 23	Left brush motor contactor coil short to ground	<ol style="list-style-type: none"> 1. Disconnect the K4 coil wiring (wire colors VIO and GRA/RED) and check to see if the code disappears. <ul style="list-style-type: none"> – If the code disappears, replace the brush contactor. – If the code does reappear, test the wiring for a short back to the battery ground. Repair or replace the defective wire. 2. If the above test doesn't remove the code, substitute a new A2 control board assembly.
 24	Center brush motor contactor coil open	<ol style="list-style-type: none"> 1. Check for an open circuit in the K3 coil and wiring (wire colors VIO and WHT/VIO). 2. Test for 36V at the K3 coil. If you get 0 Volts, check the A2 control board assembly.
 25	Center brush motor contactor coil short to ground	<ol style="list-style-type: none"> 1. Disconnect the K3 coil wiring (wire colors VIO and WHT/VIO) and check to see if the code disappears. <ul style="list-style-type: none"> – If the code disappears, replace the brush contactor. – If the code does reappear, test the wiring for a short back to the battery ground. Repair or replace the defective wire. 2. If the above test doesn't remove the code, substitute a new A2 control board assembly.
 26	Right brush motor contactor coil open	<ol style="list-style-type: none"> 1. Check for an open circuit in the K2 coil and wiring (wire colors VIO and YEL/BLU). 2. Test for 36V at the K2 coil. If you get 0 Volts, check the A2 control board assembly.

Display Code	Error/Fault Description	Correction
 27	Right brush motor contactor coil short to ground	<ol style="list-style-type: none"> 1. Disconnect the K2 coil wiring (wire colors VIO and YEL/BLU) and check to see if the code disappears. <ul style="list-style-type: none"> – If the code disappears, replace the brush contactor. – If the code does reappear, test the wiring for a short back to the battery ground. Repair or replace the defective wire. 2. If the above test doesn't remove the code, substitute a new A2 control board assembly.
 28	Scrub deck actuator open	<ol style="list-style-type: none"> 1. Check for disconnected lift actuator wiring. 2. Check for an open circuit in the motor wiring or for a defective motor. 3. Check for output voltage from the A2 control board assembly at the actuator wiring plug. It should be 36 volts. If 0 Volts, check the A2 control board assembly.
 29	Vacuum motor open	<ol style="list-style-type: none"> 1. Check for disconnected vacuum motor wiring. 2. Check for an open circuit in the vacuum motor wiring or for a defective motor. 3. Check for 36 Volts at the vacuum motor. If 0 Volts, replace the vacuum motor contactor K1.
 30	Vacuum motor contactor coil open	<ol style="list-style-type: none"> 1. Check for an open circuit in the K1 coil and wiring (wire colors VIO and BLU). 2. Test for 36V at the K1 coil. If 0 Volts, check the A2 control board assembly.
 31	K1 Vacuum motor contactor coil short to ground	<ol style="list-style-type: none"> 1. Disconnect the K1 coil wiring (wire colors VIO and BLU) and check to see if the code disappears. <ul style="list-style-type: none"> – If the code disappears, replace the motor contactor. – If the code does reappear, test the wiring for a short back to the battery ground. Repair or replace the defective wire. 2. If the above test doesn't remove the code, substitute a new A2 control board assembly.
 32	Squeegee actuator open	<ol style="list-style-type: none"> 1. Check for disconnected squeegee actuator motor wiring or plug connection. 2. Check for an open circuit in actuator motor wiring (WHT/GRN and BLU/BRN) or for a defective motor M3. 3. Check for 36 Volts at the actuator motor. If 0 Volts, check the A2 control board assembly.
 33	L1 Solution solenoid open	<ol style="list-style-type: none"> 1. Check for an open circuit in the L1 coil and wiring (wire colors VIO and YEL/GRN). 2. Test for 36V at the L1 coil. If 0 Volts, check the A2 control board assembly.

Display Code	Error/Fault Description	Correction
 34	L1 Solution solenoid short to ground	<ol style="list-style-type: none"> 1. Disconnect the L1 solenoid coil wiring (wire colors VIO and YEL/GRN) and check to see if the code disappears. <ul style="list-style-type: none"> – If the code disappears, replace the solenoid valve. – If the code does reappear, test the wiring for a short back to the battery ground. Repair or replace the defective wire. 2. If the above test doesn't remove the code, substitute a new A2 control board assembly.
 35	Solution control pump open	<ol style="list-style-type: none"> 1. Check for an open circuit in the M12 pump motor and wiring (wire colors VIO and BLU/ORN). 2. Test for 36V at the pump motor. If 0 Volts, check the A2 control board assembly.
 36	Side broom motor contactor coil open	<ol style="list-style-type: none"> 1. Check for open circuit in the K6 coil and wiring (wire colors VIO and BRN/BLK). 2. Test for 36V at the K6 coil. If 0 Volts, check the A2 control board assembly.
 37	K6 Side broom motor contactor coil short to ground	<ol style="list-style-type: none"> 1. Disconnect the K6 coil wiring (wire colors VIO and BRN/BLK) and check to see if the code disappears. <ul style="list-style-type: none"> – If the code disappears, replace the K6 contactor. – If the code does reappear, test the wiring for a short back to the battery ground. Repair or replace the defective wire. 2. If the above test doesn't remove the code, substitute a new A2 control board assembly.
 38	Side broom actuator motor open	<ol style="list-style-type: none"> 1. Use an ohmmeter to check for an open circuit in the M4 side broom actuator and its wiring (wire colors GRA/VIO and GRN/ORN). If defective, repair or replace. 2. Test for 36V at side broom actuator. If 0 Volts, check the A2 control board assembly.
 39	Auxiliary motor contactor coil open	<ol style="list-style-type: none"> 1. Check for an open circuit in the K5 coil and wiring (wire colors YEL/BRN and BLK/ORN). 2. Test for 36V at the K5 coil. If 0 Volts, check the A2 control board assembly.
 40	K5 Auxiliary motor contactor coil short to ground	<ol style="list-style-type: none"> 1. Disconnect the K5 coil wiring (wire colors YEL/BRN and BLK/ORN) and check to see if the code disappears. <ul style="list-style-type: none"> – If the code disappears, replace the K5 contactor. – If the code does reappear, test the wiring for a short back to the battery ground. Repair or replace the defective wire. 2. If the above test doesn't remove the code, substitute a new A2 control board assembly.
 41	Back-up alarm open	<ol style="list-style-type: none"> 1. Use an ohmmeter to check for an open circuit in the H1 back-up alarm and its wiring (wire colors ORN/BRN and BLU/WHT). If defective, repair or replace. 2. Test for 36V at the back-up alarm. If 0 Volts, check the A2 control board assembly.

Display Code	Error/Fault Description	Correction
 42	Back-up alarm short to ground	<ol style="list-style-type: none"> 1. The Back-up alarm and/or its +36V power feed is shorted to ground. Test the positive wire to ground for short circuit* (wire colors ORN/BRN battery + and BLU/WHT battery -). Repair or replace the defective wiring. 2. Disconnect the alarm and test to see if the circuit wiring is still causing an error code (shorted). If not, replace the back-up alarm.

* Short Circuit definition:

- A short circuit is a parallel path of very low resistance, often caused accidentally.
- With low resistance there is an excessive amount of current.
- The excessive current will either melt the wires or open a fusible link.

** See **Service Test Mode** in this manual for further troubleshooting information.

*** See the **Main Control Programming Options** section to activate the Brush Type Selection function.

Removal and Installation



Warning! Before removing or reinstalling any machine components, disconnect the battery pack by pushing in the emergency-stop switch/battery disconnect, and make sure the parking brake is engaged.

A2 Control Board Assembly

1. Remove the electrical panel cover assembly (located to the left of the operator position). Make sure to unplug the fan assembly before removing the electrical panel cover assembly from the machine.
2. Disconnect the electrical connectors from the **A2 Control Board Assembly**.
3. Remove the five **Screws** holding the **A2 Control Board Assembly** to the **Electrical Mount** and remove the **A2 Control Board Assembly** from the machine.
4. Install the **A2 Control Board Assembly** by following the above steps in reverse order.

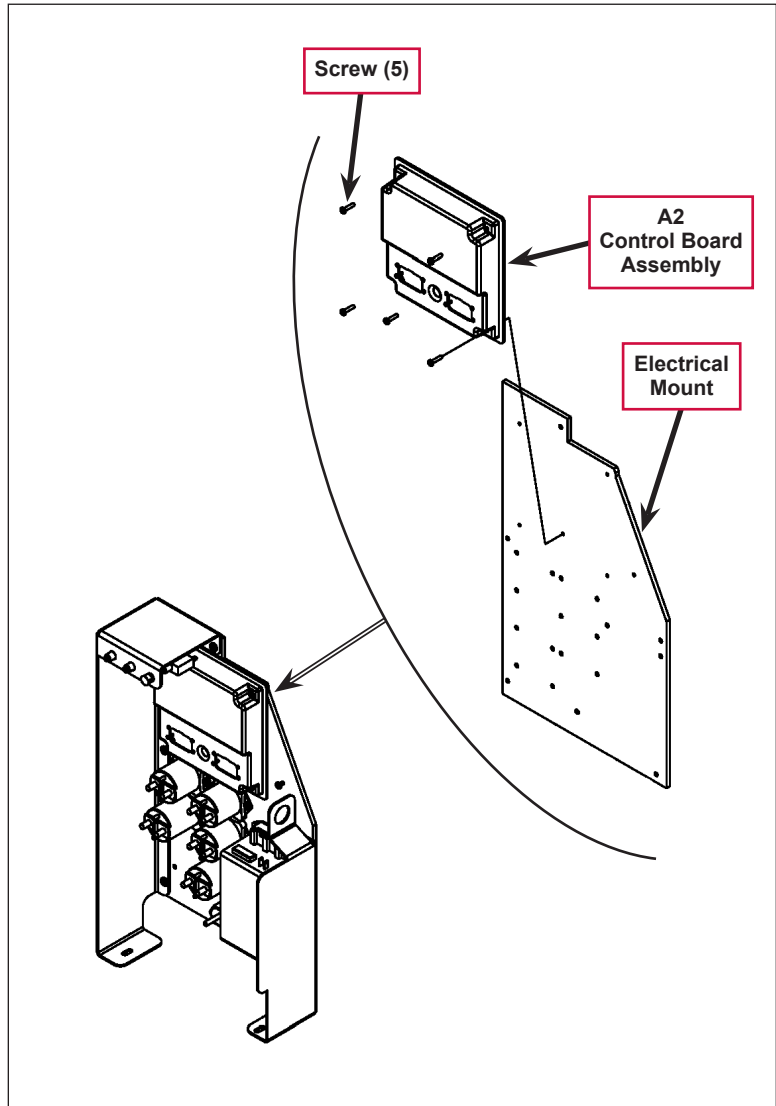

Specifications

Scrub Pressure and Current Load (Amps) Specifications					
Scrub Mode	Scrub Pressure Indicator	Deck Type			
		Disc 40"	Cyl. 40"	Disc 45"/48"	Cyl. 45"/48"
Normal Scrub	1 bar (#1)	40 amps	35 amps	50 amps	35 amps
Heavy Scrub	2 bars (#2)	50 amps	45 amps	60 amps	45 amps
Extreme Scrub	3 bars (#3)	65 amps	55 amps	80 amps	55 amps

Solution Flow Rates					
	Standard flow rates			Override flow rates	
	1 bar	2 bars	3 bars	4 bars	5 bars
40" Disc	0.84 GPM	1.00 GPM	1.50 GPM	2.00 GPM	2.50 GPM
40" Cylindrical	0.70 GPM	0.84 GPM	1.00 GPM	1.50 GPM	2.50 GPM
45"/48" Disc	1.00 GPM	1.50 GPM	2.00 GPM	2.25 GPM	2.50 GPM
45"/48" Cylindrical	0.84 GPM	1.00 GPM	1.50 GPM	2.00 GPM	2.50 GPM

I/O Tables

A2 Control Board Assembly

- Ladder Diagram: 56015372-G
- Main PCB Assy: 56381049
- Main PCB Schematic: 56381059
- UI Panel Assy: 56381083
- UI PCB Schematic: 56381061

Designation	Pin ID	Wire ID/ Color	Description	Signal Characteristics	Nominal Value (when activated)	Reference To:	Acceptable Range	Comments
Output	J1-1	BLU/GRA	Detergent Pump2 (+)	Pulsed Voltage	0 or 36V	B- (ground)	see comment below *	Complex pulsed PWM signal
Bidirectional	J1-2	BRN/BLU	CAN-L	Digital Communication	see comment		see comment	Protocol analyzer needed to verify connection
Bidirectional	J1-3	GRN/BLU	CAN-H	Digital Communication	see comment		see comment	Protocol analyzer needed to verify connection
Input	J1-4	ORN/RED	Speed Control - Fault	Voltage	see comment	B- (ground)	see comment	Pulsed signal equal to the fault code flashed by the speed controllers built-in status LED
Input	J1-5	GRN	Battery +	Voltage	+36V	B- (ground)	31V - 38V	Downstream of circuit breaker F1, Key switch S1, Diode D1, Seat Switch S2 and Battery Interlock Switch S3
Output	J1-6	TAN/BRN	Detergent Pump1 (-)	Pulsed Voltage	0 or 36V	B- (ground)	see comment below *	Line should alternate between 0V and 36V when detergent pump is activated
Output	J1-7	BLK/GRA	Detergent Pump1 (+)	Pulsed Voltage	0 or 36V	B- (ground)	see comment below *	Line should alternate between 0V and 36V when detergent pump is activated
Input	J1-8	ORN	Battery +	Voltage	+36V	B- (ground)	31V - 38V	Downstream of circuit breaker F1, switched through key switch S1
Output	J1-9	ORN/GRA	Detergent Pump2 (-)	Pulsed Voltage	0 or 36V	B- (ground)	see comment below *	Line should alternate between 0V and 36V when detergent pump is activated
Input	J1-10	BLK	Battery -	Voltage	0V	B- (ground)	0 - 1V	
Input	J1-11	RED/WHT	Speed Control - Motion	Voltage	0V (moving), 36V (not moving)	B- (ground)	0 - 1V (moving), 31 - 38V (not moving)	
Input	J1-12	YEL/RED	Speed Control - Direction	Voltage	0V (reverse), 36V (forward)	B- (ground)	0 - 1V (reverse), 31 - 38V (forward)	

Designation	Pin ID	Wire ID/ Color	Description	Signal Characteristics	Nominal Value (when activated)	Reference To:	Acceptable Range	Comments
Output	J1-13	GRA	UI Panel - Ground	Voltage	0V	B- (ground)	0 - 1V	Provides ground to User Interface panel
Input	J1-14	BLK	Battery -	Voltage	0V	B- (ground)	0 - 1V	
Input	J1-15	VIO	Battery +	Voltage	36V	B- (Ground)	31V - 38V	Downstream of circuit breaker F2, switched through contactor K5
Output	J1-16	WHT/VIO	Center Brush Contactor	Voltage	0V	B- (ground)	0 - 1V	
Output	J1-17	GRA/RED	Right Brush Contactor	Voltage	0V	B- (ground)	0 - 1V	
Output	J1-18	YEL/GRN	Solenoid Valve	Pulsed Voltage	0 or 36V	B- (ground)	see comment	Line should alternate between 0V and 36V when solenoid is activated
Output	J1-19	YEL/BLU	Left Brush Contactor	Voltage	0V	B- (ground)	0 - 1V	
Output	J1-20	BLU/RED	Horn (-)	Voltage	0V	B- (ground)	0 - 1V	
Output	J1-21	BLU/ORN	Solution Pump (-)	PWM	0 or -36V	B+	see comment below **	Pulsed PWM signal. Switched ground return for pump.
Output	J1-22	WHT/BRN	UI Panel - Power Supply	Voltage	+8V	B- (ground)	7 - 9V	Provides power to User Interface panel
Input	J1-23	VIO	Battery +	Voltage	36V	B- (Ground)	31V - 38V	Downstream of circuit breaker F2, switched through contactor K5
Output	J2-1	WHT/GRN	Squeegee Actuator +	Voltage	36V	J2-9	see comment	+36V while lowering, -36V while raising
Input	J2-2	BRN	Scrub Brush Motor Shunt	Voltage	.03 - .3V	B- (ground)	.03 - .3V	
Input	J2-3	ORN/BLU	Vacuum Motor Shunt	Voltage	.10V (Single Vac) .20V (Dual Vac)	B- (ground)	.07 - .12V (Single Vac. Motor) .15 - .24V (Dual Vac. Motor)	Recovery Tank Full voltage = .083V (Single Vacuum Motor) Recovery Tank Full voltage = .166V (Dual Vacuum Motor)
Output	J2-4	ORN/BLK	Battery -	Voltage	0V	B- (ground)	0 - 1V	Return path for Scrub Deck Resistor
Output	J2-5	YEL/GRA	Brush Actuator -	Voltage	36V	J2-6	see comment	-36V while lowering, +36V while raising
Output	J2-6	RED/BLK	Brush Actuator +	Voltage	36V	J2-5	see comment	+36V while lowering, -36V while raising

Designation	Pin ID	Wire ID/ Color	Description	Signal Characteristics	Nominal Value (when activated)	Reference To:	Acceptable Range	Comments
Output	J2-7	GRN/ORN	Side Broom Actuator -	Voltage	36V	J2-8	see comment	-36V while lowering, +36V while raising
Output	J2-8	GRA/VIO	Side Broom Actuator +	Voltage	36V	J2-7	see comment	+36V while lowering, -36V while raising
Output	J2-9	BLU/BRN	Squeegee Actuator -	Voltage	36V	J2-1	see comment	-36V while lowering, +36V while raising
Input	J2-10	BLK	Battery -	Voltage	0V	B- (ground)	0 - 1V	
Input	J2-14	BLK	Battery -	Voltage	0V	B- (ground)	0 - 1V	
Output	J2-15	BRN/BLK	Side Broom Contactor	Voltage	0V	B- (ground)	0 - 1V	
Input	J2-16	GRN/WHT	Scrub Deck Sense Resistor	Voltage	1.78V, 2.5V, 3.0V, 3.57V	B- (ground)		1.78V = 40" Disk 2.50V = 40" Cylindrical 3.0V = 45"/48" Disk 3.57V = 45"/48" Cylindrical
Input	J2-17	VIO/YEL	Solution Empty Switch	Voltage	0V	B- (ground)	0 - 1V	Active when tank is empty
Output	J2-18	ORN/BRN	Backup Alarm (+)	Voltage	+15V	B- (ground)		
Output	J2-19	BLU/BLK	Speed Control - Mode Sel 1	Voltage	0 or 36V	B- (ground)		Depends on which mode the speed controller is in
Output	J2-20	BLK/WHT	Speed Control - Mode Sel 2	Voltage	0 or 36V	B- (ground)		Depends on which mode the speed controller is in
Output	J2-21	BLK/ORN	Auxiliary Contactor	Voltage	0V	B- (ground)	0 - 1V	
Output	J2-22	BLU	Vacuum Contactor	Voltage	0V	B- (ground)	0 - 1V	
Output	J2-23	BLU/WHT	Backup Alarm (-)	Voltage	0V	B- (ground)		

* The signal controlling the detergent pump is extremely complex and field troubleshooting should take a functional approach. Substitute with a known good detergent pump to check operation. If the known good pump does not operate, and the wiring and control inputs to the EcoFlex™ system is correct, the EcoFlex™ system is probably defective. Check the resistance of the detergent pump before replacing the EcoFlex™ system so as not to damage it if the pump is defective.

** The Solution Pump (-) line provides a switched ground return for the pump. When the solution pump is on, a 5KHz signal with a varying duty cycle and a peak voltage of 36 volts will appear between this pin and B+. Measuring with a DC voltmeter will give a signal in the range of 6 to 27 volts. Changing the flow rate solution bars on the LCD should produce a relative increase or decrease of the meter reading.

EcoFlex PCB Assembly

- EcoFlex™ PCB Ass'y: 56316110-B
- EcoFlex™ PCB Schematic: 56314929-B

Designation	Pin ID	Wire ID/Color	Description	Signal Characteristics	Nominal Value (when activated)	Reference To:	Acceptable Range	Comments
Input	J1-1	GRN/GRA	EcoFlex™ Board Power	Voltage	+5V	B- (ground)	4.5 - 5.5V	Supplied by control board
Input	J1-2	ORN/WHT	EcoFlex™ Board Ground	Voltage	0V	B- (ground)	0 - 1V	Supplied by control board
unused	J1-3		unused					
Output	J1-4	GRA/WHT	EcoFlex™ Chemical Ratio	Analog Voltage		B- (ground)	1 - 5V	Signal is sent to main control board

Electrical System

Functional Description

Overview

This section includes information on battery installation and maintenance, a description of the low-voltage cut-out function, and descriptions of the battery condition displays.

- For information on the A2 Control Board Assembly, refer to the ***Control System*** section.
- For information on the A1 (Curtis) Speed Controller, refer to the ***Wheel System, Traction*** section.

Condor EcoFlex™ Ladder Wiring Diagram

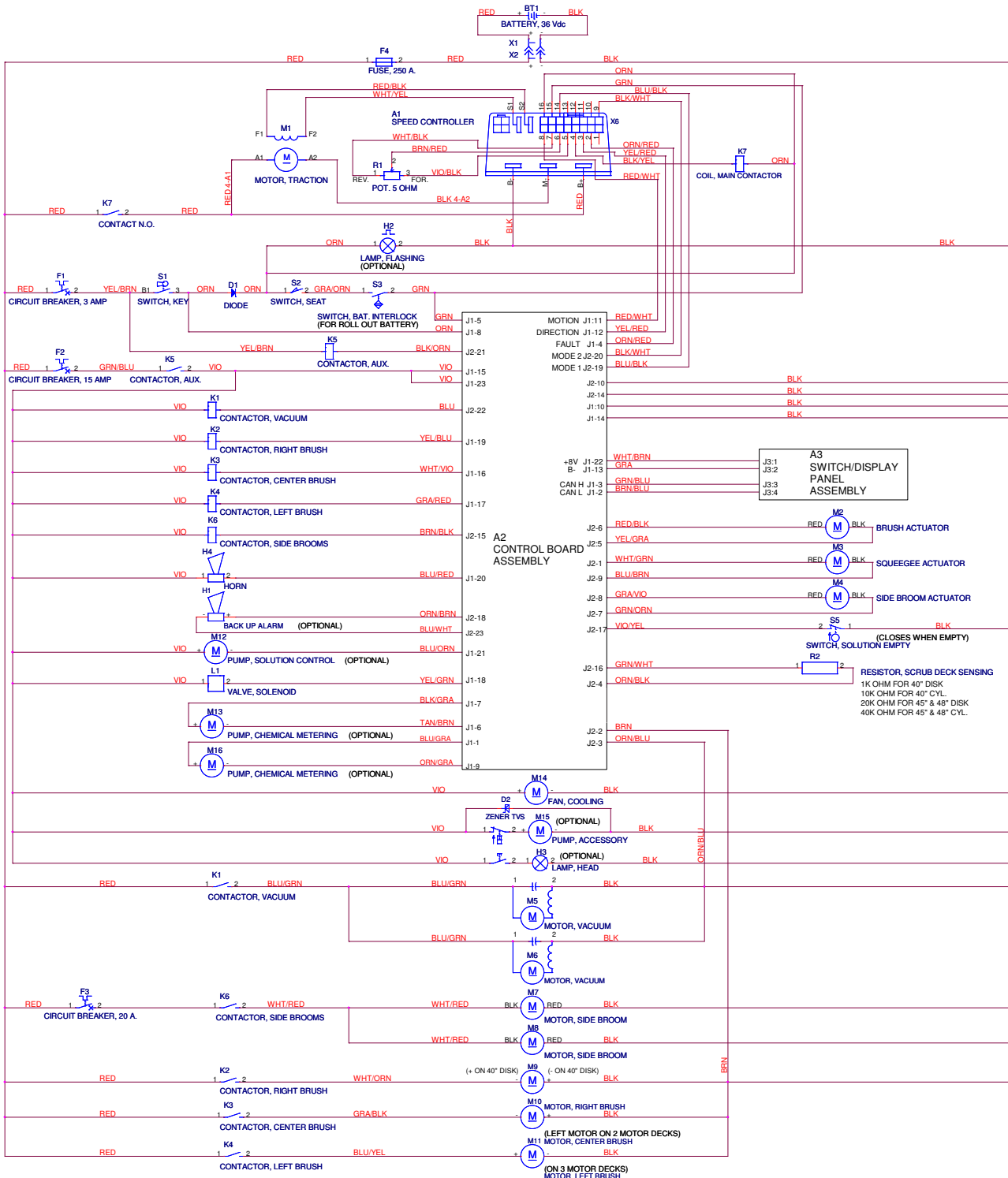

Low-voltage Cut-out Feature

All models discussed in this manual are equipped with a low-voltage cutout feature to prevent over-discharging of the batteries. When a machine's battery pack voltage falls below a specifically defined threshold (voltage settings), the scrub system automatically shuts down. The drive motor will still operate in the low-voltage cut-out mode to allow the machine to be driven to a charging location.

The low-voltage cut-out level is adjustable. The standard lead-acid battery (wet cell) setting is 1.72 volts per cell. The alternate maintenance-free battery (gel cell) setting is 1.81 volts per cell. The standard lead-acid battery setting is factory-selected and should be used unless the battery manufacturer specifies the higher cut-out voltage.



Service Note: A minimum recharge voltage of 2.13 volts per cell must be reached to allow the scrub and solution systems to function again (reset). A 36-volt battery pack must increase to a 38.6-volt minimum.

Battery Condition Indicator

The battery indicator displays the state of battery charge. Five vertical bars indicates a fully-charged battery after a complete charging cycle. The battery indicator will retain the state-of-charge even if the key switch has been turned off. The state-of-charge indicator is reset to full charge when the batteries have been recharged. It is also possible to choose between two different low-voltage thresholds depending on whether maintenance-free or standard (lead-acid) batteries are being used (Have a qualified service engineer perform this selection*.)



Note: The following percentages are based on usable battery capacity, not total battery capacity. Therefore, 100% discharge = 80% of total battery capacity for standard wet-cell batteries, or 70% of total battery capacity for maintenance-free batteries.

Battery Indicator	Standard	Alternate
5 vertical indicator bars	36.1+	36.1+
4 vertical indicator bars	35.5-36.1	35.5-36.1
3 vertical indicator bars	34.4-35.5	34.4-35.5
2 vertical indicator bars	33.9-34.4	33.9-34.4
1 vertical indicator bars	32.2-33.9	33.3-33.9
0 vertical indicator bars	30.9-32.2	32.8-33.3
Low-voltage Cut-out	<30.9	<32.8



Battery Location

The **Batteries** are located in the battery compartment behind the operator seat and underneath the recovery tank.

The **Battery Disconnect** is mounted on the right side of the operator seat.

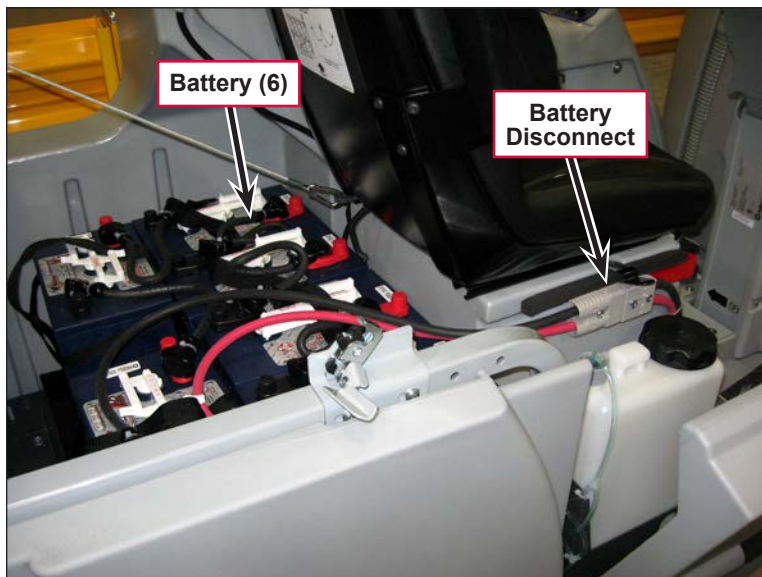

Maintenance and Adjustments



Warning! Before performing any machine maintenance or adjustments, make sure the key switch is off and the key is removed from the machine.

Wet-cell Battery Maintenance

Correct maintenance of electric vehicle batteries can greatly extend their life. Well-maintained batteries may last up to three years, but failure after one year is common if maintenance has been inadequate.

There are three simple rules for good battery maintenance:

- Maintain the correct electrolyte level (check weekly). Use distilled water in batteries whenever possible. If batteries are discharged, add just enough water to cover the plates in each cell. If batteries are fully-charged, fill each cell to the bottom of the filler tube. *Do not overfill the batteries! Do not add acid to batteries!*
- Keep the batteries charged (charge weekly). Batteries should be charged each time that a machine is used for more than one hour. The battery compartment cover should be open during charging to avoid a concentrated buildup of hydrogen gas. Operators should follow the instructions provided with their specific battery charger to determine how long the batteries should be charged. Even when a machine is stored, the batteries should be charged once a month to prevent the batteries from “sulfating”. Almost all battery caps are vented, so there’s no need to loosen or remove them for charging.
- Keep the batteries clean (check and clean monthly). Use a damp cloth to wipe dirt from the top of the batteries. Battery terminals must be clean and tight. If the tops of the batteries are wet after charging, the batteries have probably been overfilled or overcharged.



Note: If there is acid on the batteries, wash the tops of the batteries with a solution of two tablespoons of baking soda to one quart/liter of water.

Checking the Battery Water Level

1. Check the water level of the batteries at least once a week.
2. After charging the batteries, remove the vent caps and check the water level in each battery cell. Use distilled or demineralized water in a battery filling dispenser (available at most auto parts stores) to fill each cell to the level indicator (or to approximately 3/8" [10 mm] over the top of the separators). *Do not overfill the batteries!*



Caution! Acid can spill onto the floor if the batteries are overfilled.

3. Tighten the vent caps.
4. Wash the tops of the batteries with a solution of baking soda and water. Use a mixture of two tablespoons of baking soda to one quart/liter of water).

Charging Wet-cell Batteries

Charge the batteries each time the machine is used, or when the battery indicator is reading less than full.

To Charge the Batteries

1. Disconnect the machine battery connector.
2. Open the side access panel and push the connector from the charger into the battery connector.
3. Follow the instructions on the battery charger.
4. After charging the batteries, check the fluid level in all battery cells. Add distilled water if necessary to bring the fluid level up to the bottom of the filler tubes.



Warning!

- **Do not fill the batteries before charging.**
- **Charge the batteries in a well-ventilated area.**
- **Do not smoke while servicing the batteries.**

When Servicing Batteries

- Remove all jewelry.
- Do not smoke.
- Wear safety glasses, rubber gloves and a rubber apron.
- Work in a well-ventilated area.
- Do not allow tools to touch more than one battery terminal at a time.
- ALWAYS disconnect the negative (ground) cable first when replacing batteries to prevent sparks.
- ALWAYS connect the negative cable last when installing batteries.



Caution! To avoid damage to floor surfaces, wipe water and acid from the top of the batteries after charging.

Troubleshooting

Battery Testing

A battery problem is usually recognized by the machine operator as a decrease in the machine's running time. This condition is usually caused by one or more "dead cells" in the battery system – that is, one or more cells that are putting out less voltage than the other cells.



Note: Always charge batteries before testing.

There are two ways to find a dead cell:

- Use a voltmeter to check the voltage of each battery with the scrub and drive motors running. The battery with the dead cell will read 1 or 2 volts lower than the other batteries in the system.
- Use a hydrometer to check the specific gravity (or "state of charge") of the fluid in each cell. A dead cell is one that reads 50 points (or more) lower than the other cells.

If the batteries in the machine are more than one year old, it's usually best to replace the whole set rather than replacing just one battery.

Approximate State of Charge Corresponding to Electrolyte Specific Gravity	
State of Charge	Specific Gravity
Charged	1.265 Initial Full Charge
100%	1.265
75%	1.225
50%	1.190
25%	1.155
Discharged	1.120

General Troubleshooting

Problem	Cause	Correction
No Power to the Machine	The emergency stop switch/battery disconnect by the Operator seat is not connected.	Connect the emergency stop switch/battery disconnect.
	There is a problem on the battery wiring or connections.	Check the wiring and connections and clean/repair as necessary.
	The 250-amp fuse (F4) is blown.	Replace the fuse.
Short machine run time.	Weak batteries or battery/batteries with a dead cell.	Charge and test the batteries. Replace as necessary.

Removal and Installation



Warning! Before removing or reinstalling any machine components, make sure the key switch is off and the key is removed from the machine.

To Install the Batteries



Warning!

- Use extreme caution when working with batteries. Sulfuric acid in batteries can cause severe injury if allowed to contact the skin or eyes.
- Explosive hydrogen gas is vented from the batteries through openings in the battery caps. This gas can be ignited by any spark, flame or electrical arc. Do not install any lead-acid battery in a sealed container or enclosure. Hydrogen gas from overcharging must be allowed to escape.



Caution!

- Electrical components in this machine can be severely damaged if the batteries are not installed and connected correctly.
 - The batteries must be installed only by an Advance representative or dealer, a qualified electrician or the battery manufacturer.
1. Remove the batteries from their shipping crate and carefully inspect them for cracks or other damage. If damage is evident, contact the carrier that delivered them, or the battery manufacturer, to file a damage claim.
 2. Turn the key switch off and remove the key.
 3. Remove the recovery tank from the machine. (Refer to the [Recovery System/Removal and Installation/Recovery Tank](#) section.)
 4. Your machine comes from the factory with enough battery cables to install six 6-volt batteries. Using at least two people and an appropriate lifting strap, carefully lift the batteries into the battery compartment and arrange them exactly as shown. Secure the batteries as close to the front of the machine as possible. If installing a monoblock battery, use an overhead hoist.
 5. Install the battery cables as shown. Position the cables so the battery caps can be removed easily for battery service.

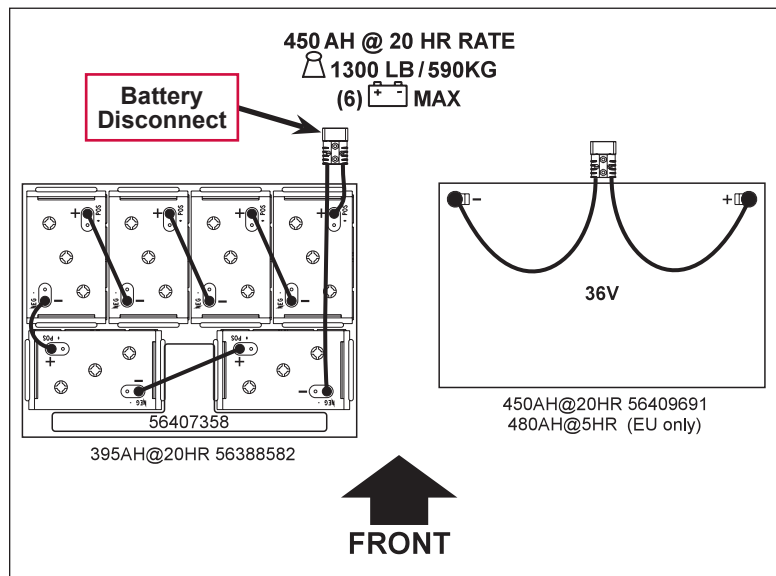

6. Carefully tighten the nut in each battery terminal until the terminal will not turn. Do not overtighten the terminals or they will be very difficult to remove for future service.
7. Coat the terminals with spray-on battery terminal coating (available at most auto parts stores).
8. Put one of the black rubber boots over each of the terminals and connect the **Battery Disconnect**.

Specifications

Component	Specifications
Wet Cell Batteries	Use a combination of multiple 2-volt cell units to construct a 36-volt DC battery pack system.
	Advance-recommended battery pack capacity is a 395 AH @ 20 Hour Rate deep cycle battery system. Note that the battery pack must fit the battery compartment size listed in the Technical Specifications .
Wet Cell Battery Charger	Use a 36-volt DC output charger matching the DC battery pack voltage and the input AC line voltage supply being used.
	When selecting a battery charger always follow the recommendation of the battery supplier to match the correct charger DC output amperage to the amp-hour rating batteries being installed. This will prevent the battery pack from being overcharged or undercharged.
	The recommended 395 AH battery should be matched to a 36-volt, 36-amp output charger on machines using six 6-volt batteries.
	The optional 450 AH battery should be matched to the Advance 36-volt, 38-amp output charger.

Special Tools

A hydrometer can be used to check the specific gravity of the battery electrolyte. A typical example is shown here.



Options and Accessories

Brush Selector Guide

- **ProLite:** Light-duty polypropylene for general scrubbing.
- **Prolene:** Medium-duty scrubbing on concrete, terrazzo and vinyl floor tile.
- **Union Mix:** Used for polishing floors.
- **Soft Nylon:** For use on light dust coated floors where long life is required.
- **Hard Nylon:** For general use on concrete floors where long life is required.
- **AgLite Grit:** General scrubbing of urethane coated, sealed or other hard surfaces.
- **MidGrit:** Lighter action general purpose scrubbing on sealed or unsealed concrete.
- **MidLite Grit:** General purpose scrubbing of sealed or unsealed concrete floors.
- **Dyna Grit:** Heavy-duty scrubbing on concrete floors.
- **Magna Grit:** Extreme heavy-duty scrubbing on concrete floors.

4030D Pad Holders and Disc Brushes (two required)

Description
Short trim pad holder with pad retainer, 20 inch [51 cm]
Pad retainer/centering device only, snap lock
Prolite disc brush, 20 inch [51 cm]
Prolene disc brush, 20 inch [51 cm]
Union Mix disc brush, 20 inch [51 cm]
AgLite Grit 500 disc brush, 20 inch [51 cm]
MidGrit 240 disc brush, 20 inch [51 cm]
MidLite Grit 180 disc brush, 20 inch [51 cm]
Dyna Grit 80 disc brush, 20 inch [51 cm]
Magna Grit 46 disc brush, 20 inch [51 cm]

4030C Cylindrical Brushes and Side Brooms (two of each required)

Description
Soft nylon cylindrical brush, 40 inch [102 cm]
Hard nylon cylindrical brush, 40 inch [102 cm]
Prolene cylindrical brush, 40 inch [102 cm]
MidLite 180 cylindrical brush, 40 inch [102 cm]
Dyna Grit 80 cylindrical brush, 40 inch [102 cm]
Side broom, polypropylene, all-purpose
Side broom, polypropylene, finer bristles for delicate surfaces

4530D Pad Holders and Disc Brushes (three required)

Description
Short-trim pad holder with pad retainer, 16 inch [41 cm]
Pad retainer/centering device only, snap lock
ProLite disc brush, 16 inch [41 cm]
Prolene disc brush, 16 inch [41 cm]
Union Mix disc brush, 16 inch [41 cm]
AgLite Grit 500 disc brush, 16 inch [41 cm]
MidGrit 240 disc brush, 16 inch [41 cm]
MidLite Grit 180 disc brush, 16 inch [41 cm]
Dyna Grit 80 disc brush, 16 inch [41 cm]
Magna Grit 46 disc brush, 16 inch [41 cm]

4530C Cylindrical Brushes and Side Brooms (two of each required)

Description
Soft nylon cylindrical brush, 45 inch [114 cm]
Hard nylon cylindrical brush, 45 inch [114 cm]
Prolene cylindrical brush, 45 inch [114 cm]
MidLite 180 cylindrical brush, 45 inch [114 cm]
Dyna Grit 80 cylindrical brush, 45 inch [114 cm]
Side broom, polypropylene, all-purpose
Side broom, polypropylene, finer bristles for delicate surfaces

4830D Pad Holders and Disc Brushes (three required)

Description
Short-trim pad holder with pad retainer, 17 inch [43 cm]
Pad retainer/centering device only, snap lock
ProLite disc brush, 17 inch [43 cm]
Prolene disc brush, 17 inch [43 cm]
Union Mix disc brush, 17 inch [43 cm]
AgLite Grit 500 disc brush, 17 inch [43 cm]
MidGrit 240 disc brush, 17 inch [43 cm]
MidLite Grit 180 disc brush, 17 inch [43 cm]
Dyna Grit 80 disc brush, 17 inch [43 cm]
Magna Grit 46 disc brush, 17 inch [43 cm]

4830C Cylindrical Brushes and Side Brooms (two of each required)

Description
Soft nylon cylindrical brush, 48 inch [122 cm]
Hard nylon cylindrical brush, 48 inch [122 cm]
Prolene cylindrical brush, 48 inch [122 cm]
MidLite Grit 180 cylindrical brush, 48 inch [122 cm]
Dyna Grit 80 cylindrical brush, 48 inch [122 cm]
Side broom, polypropylene, all-purpose
Side broom, polypropylene, finer bristles for delicate surfaces

4030C/D Squeegee Kits

Description
46 inch [117 cm] squeegee blade kit, gum rubber, includes front and rear blade
46 inch [117 cm] squeegee blade kit, Linatex®, includes front and rear blade
46 inch [117 cm] squeegee blade kit, polyurethane, includes front and rear blade
Cylindrical deck side skirt, gum rubber, 1 each (2 required per deck)
Cylindrical deck side skirt, Linatex®, 1 each (2 required per deck)
Cylindrical deck side skirt, polyurethane, 1 each (2 required per deck)
Disc deck skirt kit, gum rubber, includes left and right blades
Disc deck skirt kit, Linatex®, includes left and right blades
Disc deck skirt kit, polyurethane, includes left and right blades

4530C/D Squeegee Kits

Description
52 inch [131 cm] squeegee blade kit, gum rubber, includes front and rear blade
52 inch [131 cm] squeegee blade kit, Linatex®, includes front and rear blade
52 inch [131 cm] squeegee blade kit, polyurethane, includes front and rear blade
Cylindrical deck side skirt, gum rubber, 1 each (2 required per deck)
Cylindrical deck side skirt, Linatex®, 1 each (2 required per deck)
Cylindrical deck side skirt, polyurethane, 1 each (2 required per deck)
Disc deck skirt kit, gum rubber, includes left and right blades
Disc deck skirt kit, Linatex®, includes left and right blades
Disc deck skirt kit, polyurethane, includes left and right blades

4830C/D Squeegee Kits

Description
55 inch [140 cm] squeegee blade kit, gum rubber, includes front and rear blade
55 inch [140 cm] squeegee blade kit, Linatex®, includes front and rear blade
55 inch [140 cm] squeegee blade kit, polyurethane, includes front and rear blade
Cylindrical deck side skirt, gum rubber, 1 each (2 required per deck)
Cylindrical deck side skirt, Linatex®, 1 each (2 required per deck)
Cylindrical deck side skirt, polyurethane, 1 each (2 required per deck)
Disc deck skirt kit, gum rubber, includes left and right blades
Disc deck skirt kit, Linatex®, includes left and right blades
Disc deck skirt kit, polyurethane, includes left and right blades

Options and Accessories

Description
Heavy duty front bumper
Deluxe Grammer seat kit (in lieu of standard)
Refillable detergent cartridge, 2.5 gallons [9.5 L]
Onboard Scrub, Spray and Vacuum kit includes: mounting bracket, vacuum hose w/ solution line, 2 piece stainless steel heavy duty wand with hard floor and soft floor shoes.
CoolTool spray and scrub wand kit
Recovery tank drain hose extension - 11.5 ft [3.5 m]
Floor mat kit
2nd vacuum motor kit
Warning beacon kit
Front headlight kit
Back-up alarm kit
Seat belt kit
Overhead guard
Operator foot guard kit
Battery exchange cart
Solution auto-fill kit
Two position roller battery charger station (charger not included)
Battery tray for (6) 420 AH batteries (batteries not included)
Battery roll out kit (batteries not included)

Batteries and Chargers

Description
375 AH C6 monoblock battery
375 AH C6 monoblock battery with roll on roll off kit
450 AH C6 monoblock battery
Shelf charger, single phase 230 VAC / 36 VDC, 38A, for 375 AH C6 battery
Shelf charger, single phase SCR 240/480 VAC / 36 VDC, 96A max, for 450 AH C6 battery
Shelf charger, three phase SCR 240/480 VAC / 36 VDC, 88A max, for 450 AH C6 battery

Deck Kits (includes deck and squeegee, brushes sold separately)

Description
40 inch [102 cm] disc deck (fits disc units only)
40 inch [102 cm] cylindrical deck (fits cylindrical units only)
45 inch [114 cm] disc deck (fits disc units only)
45 inch [114 cm] cylindrical deck (fits cylindrical units only)
48 inch [122 cm] disc deck (fits disc units only)
48 inch [122 cm] cylindrical deck (fits cylindrical units only)

Extended Warranty

Description
3 year / 3000 hours parts and labor from in-service date
4 year / 4000 hours parts and labor from in-service date

Recovery System

Functional Description

Overview

The recovery system picks up the scrubbing solution from the squeegee tool and directs it to the **Recovery Tank**.

Recovery Tank

The **Recovery Tank** holds 70 gallons [265 l] of wastewater and supports the **Vacuum Motor**, **Recovery Tank Lid** and **Top Cover Assembly**.

Vacuum Motor

The **Vacuum Motor** draws air from the **Recovery Tank** to create a vacuum in the tank and at the **Squeegee**.

The **Vacuum Motor** switches on automatically when the scrub system is enabled and the machine moves forward. The **Vacuum Motor** will switch off after a predetermined time delay once machine motion stops.

The **Vacuum Motor** can also be switched on independent of the scrub system by pressing the vacuum/wand switch. This is used to pick up solution already on the floor, or when using a wand on the **Squeegee Hose**.

A current sensor monitors the **Vacuum Motor** current and will display a fault if the **Vacuum Motor** current draw is too high.

Squeegee and Squeegee Hose

The wastewater and air enter the vacuum system at the **Squeegee** tool through small openings (notches) located in the front **Squeegee** blade. The small openings are the entrance points for the water and air and help speed up the airflow, producing the suction to lift the wastewater off of the floor. The solution travels through the **Squeegee Hose** at high speed and into the **Recovery Tank**. The airflow continues through the **Recovery Tank**, vacuum fan inlet screen and **Vacuum Motor**, then is exhausted out of the **Vacuum Hose**. No wastewater ever actually moves through the **Vacuum Motor**, just the working air.

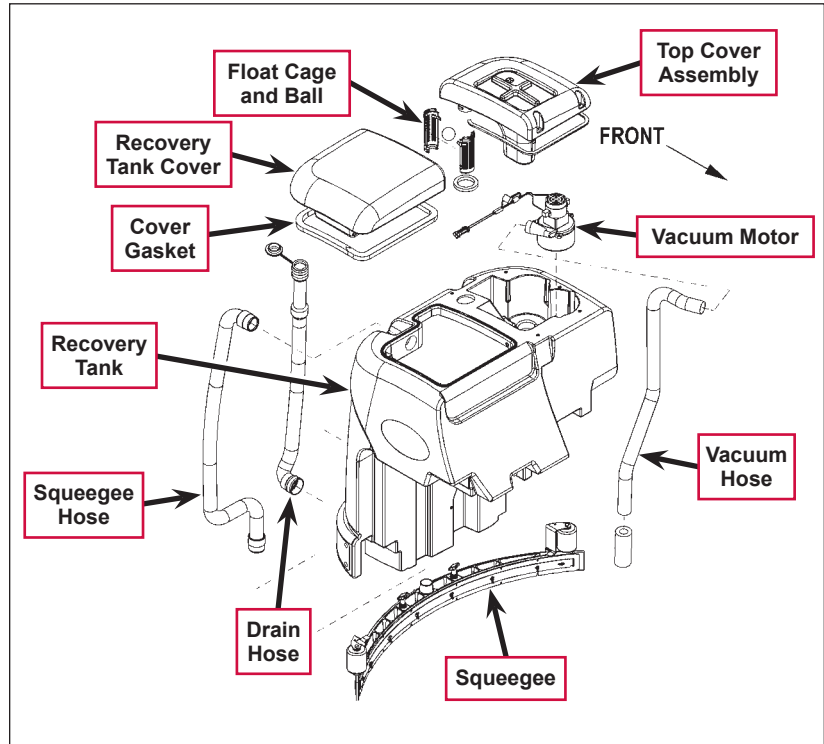

Float Cage and Ball

A shutoff **Float Cage and Ball** prevent the **Recovery Tank** from being overfilled and stops any water from being sucked into the **Vacuum Motor**. When the **Float Ball** rises (to full-tank level) it will seat itself inside the **Cage** assembly and block off the **Vacuum Motor** airflow. This causes a reduced **Vacuum Motor** current load which is sensed by the A2 control board which automatically shuts off the vacuum and scrub systems.

The LCD will then display the recovery tank full indicator icon to alert the operator that the recovery tank needs to be drained.

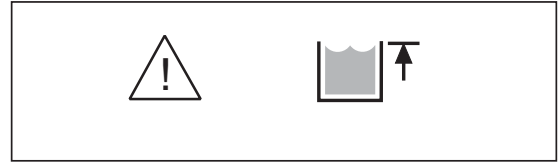

Recovery System Wiring Diagram

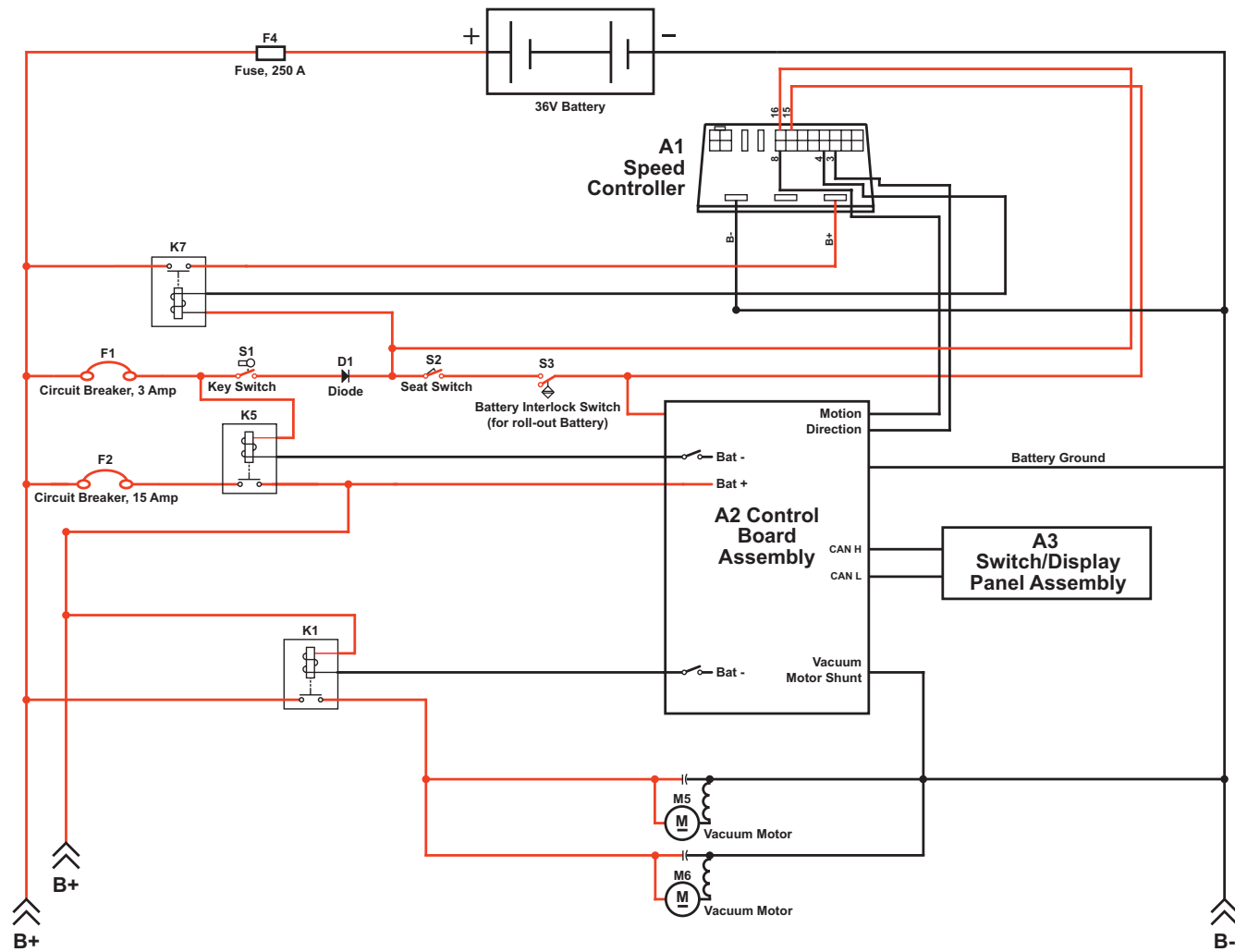

Circuit Description

Vacuum Motors M5 and **M6** get positive voltage from the **Battery** when the load sides of contactors **K5** and **K1** are closed. Contactors **K5** and **K1** close when the **A2 Control Board Assembly** connects the **K5** and **K1** contactor coils to battery ground. **Vacuum Motors M5** and **M6** are connected directly to battery ground.

The **A2 Control Board Assembly** connects the **K5** and **K1** contactor coils to battery ground when:

- The **A3 Switch/Display Panel Assembly** sends the **A2 Control Board Assembly** a signal via the CAN BUS that the vacuum system has been switched on, or,
- The **A1 Speed Controller** sends the **A2 Control Board Assembly** a signal that the wheel drive is switched on, the scrub system is enabled and the vacuum system has not been switched off.



Note: The **A2 Control Board Assembly** monitors the voltage input from the **Vacuum Motor Shunt** wire connected to the ground side of **Vacuum Motors M5** and **M6**. If the voltage is out of the acceptable range (.07 - .12 volts for a single vacuum motor or .15 - .24 volts for dual vacuum motors), the **A2 Control Board Assembly** will sense that the float ball is sealed against the float cage and that the recovery tank is full. The **A2 Control Board Assembly** will then shut down the vacuum and scrub systems and display a recovery tank full icon on the LCD.

Component Locations

Vacuum Motor and Vacuum Hose

The **Vacuum Motor** sits in a cavity in the **Recovery Tank**. To access the **Vacuum Motor**, remove the five Phillips screws and washers holding the top cover assembly on the recovery tank and remove the top cover assembly.

Note that there is room in the **Recovery Tank** for an optional second **Vacuum Motor**.

The **Vacuum Hose** is clamped to the outlet side of the **Vacuum Motor** and exhausts the airflow from the **Vacuum Motor** through to the underside of the machine.

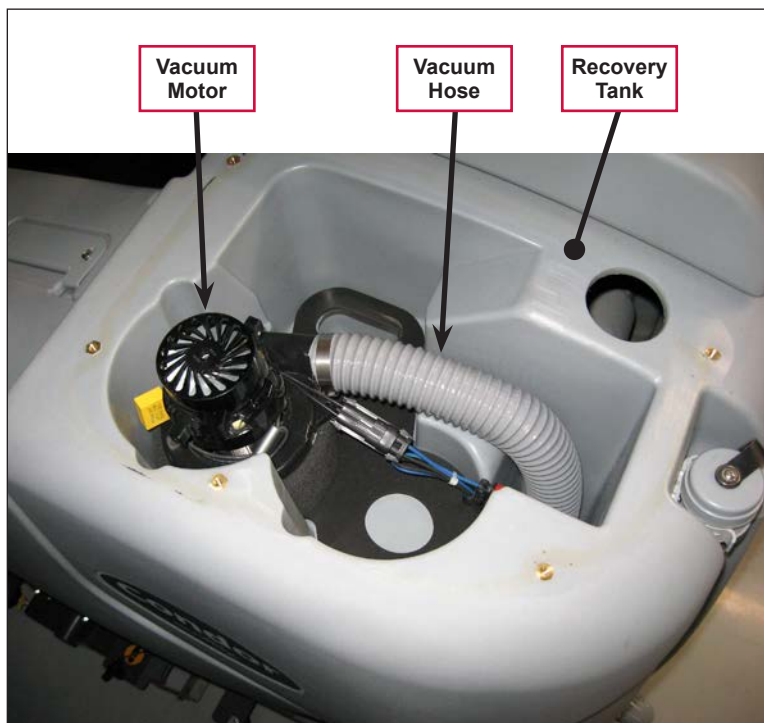

Top Cover Assembly

The **Top Cover Assembly** is fastened to the top of the recovery tank and includes the **Vacuum Filter Lid**, **Filter**, **Filter Screen** and **Recovery Tank Top**. The **Vacuum Cover Plate**, **Float Cage** and contained **Float Ball** attach to the bottom of the **Recovery Tank Top**. The **Vacuum Fan Top Gasket** seals the **Top Cover Assembly** to the recovery tank.

Float Cage and Ball

The **Float Ball** is retained inside the two-piece interlocking **Float Cage**. The assembled **Float Cage** and **Float Ball** attach to the bottom of the **Recovery Tank Top**.

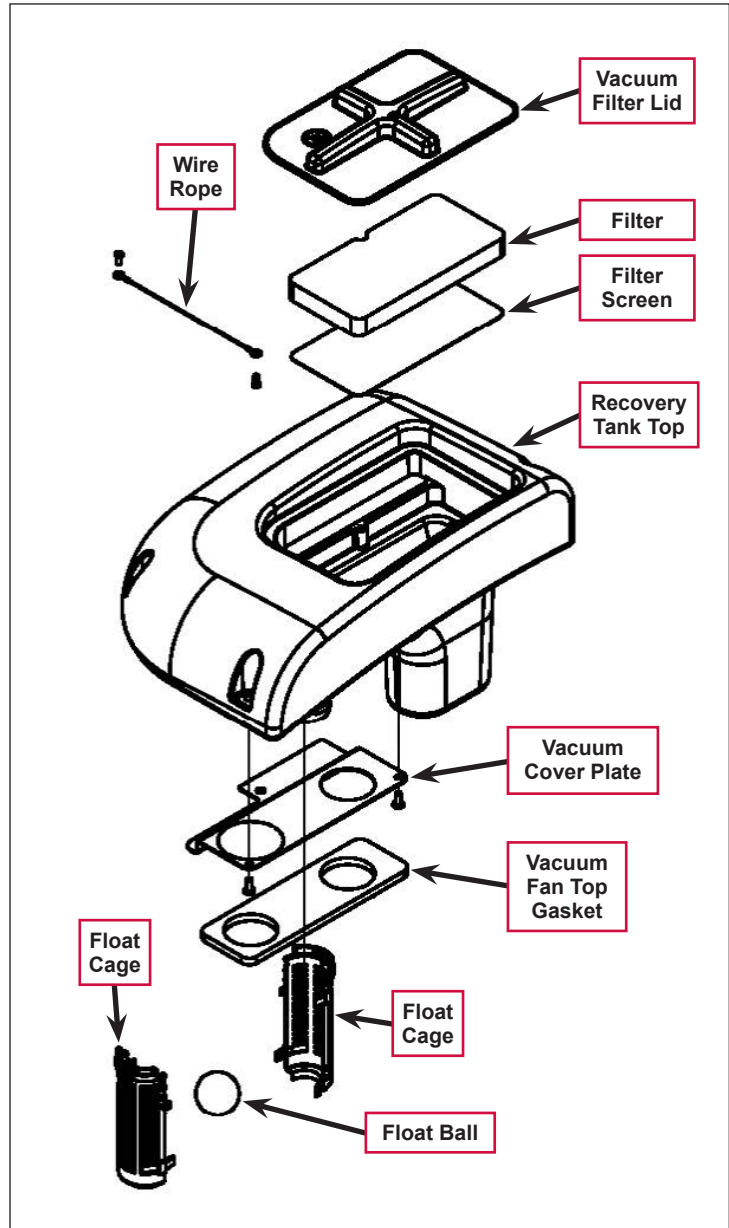

Recovery Tank Lid

The **Recovery Tank Lid** is hinged and opens to allow access to the **Recovery Tank**.

Squeegee and Drain Hoses

The **Squeegee Hose** and **Drain Hoses** are mounted on the rear of the **Recovery Tank**.

The **Squeegee Hose** connects the squeegee to the inlet port on the **Recovery Tank**.

The **Drain Hose** allows you to drain the **Recovery Tank** by removing the **Drain Hose Cap**.

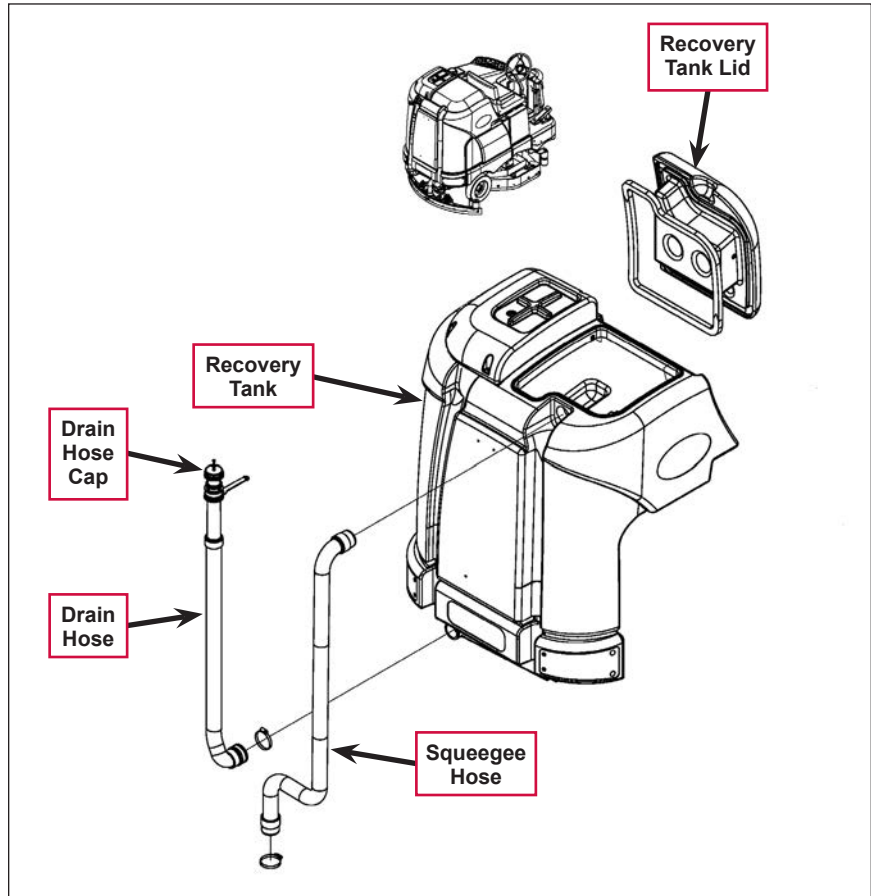

Maintenance



Warning! Before performing any machine maintenance or adjustments, make sure the key switch is off, the key is removed from the machine and the parking brake is engaged.

To Inspect and Clean the Vacuum Filter and Inlet Screen

1. Open the tethered **Vacuum Filter Lid**.
2. Remove the **Filter** and **Filter Screen** by pulling them out of the recess in the **Recovery Tank Top**.
3. Clean the **Filter** and **Filter Screen** with vacuum or by washing them in warm water.
4. When the **Filter** and **Filter Screen** are clean and dry, reinstall them into the **Recovery Tank Top**.



Service Note: The **Filter** and **Filter Screen** must be completely dry before reinstalling.

5. Replace the **Vacuum Filter Lid**.

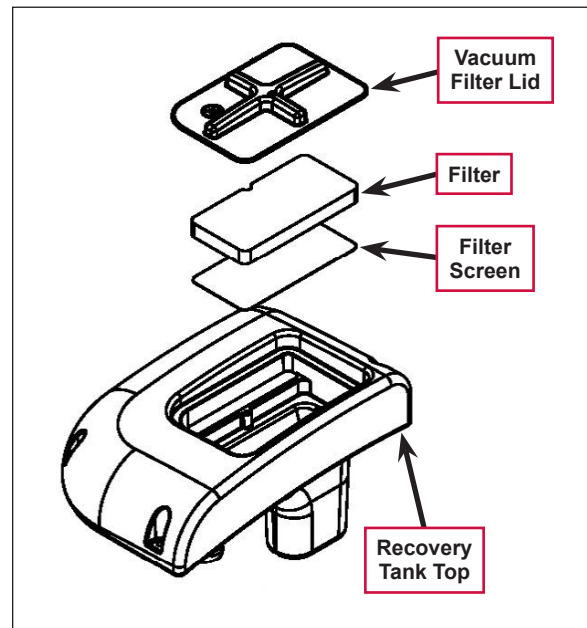

To Inspect and Clean the Vacuum Motor Float Cage

1. Lift the **Recovery Tank Lid** to access the **Float Cage** and captive float ball. The **Float Cage** is attached to the underside of the **Top Cover Assembly**.
2. Carefully remove the **Float Cage** from the **Top Cover Assembly**. Note that the **Float Cage** is a two-piece design and can be snapped apart to separate for cleaning.
3. Clean any debris from the **Float Cage** slots with a rag, or by flushing the **Float Cage** with water. The **Float Cage** slots must be kept clean to prevent any airflow restriction.
4. Reassemble the **Float Cage** and captive float ball and reinstall into the **Top Cover Assembly**.
5. Inspect the **Recovery Lid Gasket** to make sure it is not damaged and is sealing correctly.

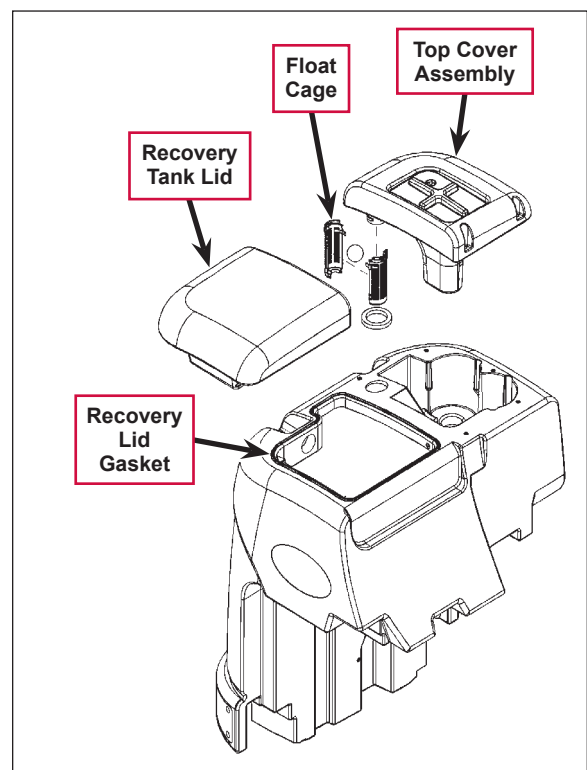

Troubleshooting

If water flows around the ends of the squeegee tool instead of being pulled into the tool, the vacuum system is not working correctly. This is usually due to either vacuum leaks, or restrictions in the squeegee tool, vacuum hoses or float cage.

Problem	Cause	Correction
Poor water pickup	* Vacuum leak(s) due to: <ul style="list-style-type: none"> • Leaky drain hose cap • Leaky hose • Bad gasket • Damaged tank 	<ul style="list-style-type: none"> • Check the drain hose cap and tighten/replace as necessary. • Check the squeegee and recovery tank hoses and tighten/replace as necessary. • Check the gaskets and replace as necessary. • Check the recovery tank for damage.
	Restrictions due to built-up debris in the squeegee tool, vacuum hoses or float cage	<ol style="list-style-type: none"> 1. Check the squeegee tool, vacuum hoses and float cage for any accumulated dirt or debris and clean as necessary. 2. Check the vacuum system airflow pathway wherever the airflow is forced to make a sharp turn for any accumulated dirt or debris and clean as necessary.
Vacuum motor(s) will not run.	Vacuum motor overload (error code 09 displayed)	<ol style="list-style-type: none"> 1. Check for debris in the vacuum motor(s). 2. Check for worn carbon brushes - replace brushes. 3. Defective motor bearings - repair or replace. 4. Check for a short circuit in the vacuum motor or wiring - repair or replace.
	Vacuum motor contactor coil overload (error code 10 displayed)	<ol style="list-style-type: none"> 1. Check for a K1 coil wiring problem or short circuit (wire colors VIO and BLU). 2. Check the coil resistance. If the coil resistance is below 80 ohms, replace the coil.
	Vacuum motor open (error code 29 displayed)	<ol style="list-style-type: none"> 1. Check for disconnected vacuum motor wiring. 2. Check for an open circuit in the vacuum motor wiring or for a defective motor. 3. Check for 36 Volts at the vacuum motor. If 0 Volts, replace the vacuum motor contactor K1.
	Vacuum motor contactor coil open (error code 30 displayed)	<ol style="list-style-type: none"> 1. Check for an open circuit in the K1 coil and wiring (wire colors VIO and BLU). 2. Test for 36V at the K1 coil. If 0 Volts, check the A2 control board assembly.
	K1 Vacuum motor contactor coil short to ground (error code 31 displayed)	<ol style="list-style-type: none"> 1. Disconnect the K1 coil wiring (wire colors VIO and BLU) and check to see if the code disappears. <ul style="list-style-type: none"> – If the code disappears, replace the motor contactor. – If the code does reappear, test the wiring for a short back to the battery ground. Repair or replace the defective wire. 2. If the above test doesn't remove the code, substitute a new A2 control board assembly.

* A vacuum leak below the waterline will create turbulence in the recovery tank, causing water to enter the vacuum motor(s).

Removal and Installation



Warning! Before removing or reinstalling any machine components, disconnect the battery pack by pushing in the emergency-stop switch/battery disconnect, and make sure the parking brake is engaged.

Recovery Tank

1. Drain the recovery tank.
2. Disconnect the squeegee hose from the squeegee tool, and from the top of the recovery tank (twist the hose to remove).



Note: Removing the squeegee tool at the mount will allow more room to maneuver when removing the recovery tank.

3. Disconnect the **Vacuum Motor Wiring Connector** located underneath the left rear bottom of the recovery tank.

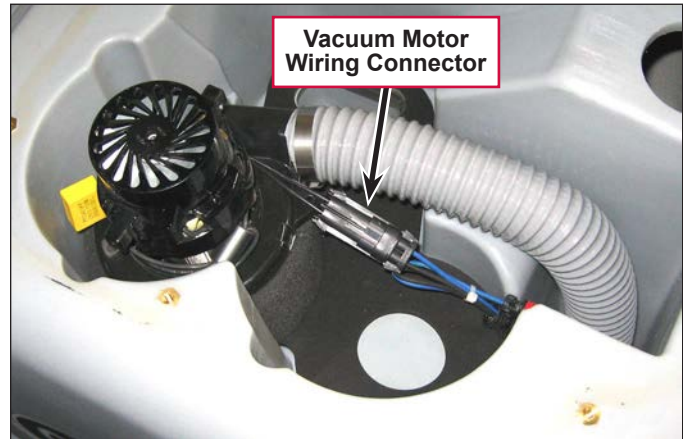

4. Release the **Tank Latch** and tilt the tank toward the rear.



5. Disconnect the **Tank Tether** from the back of the operator seat.



Caution: *Maintain a good grip on the recovery tank and control the tank as you lower it. Do not allow the tank to fall to the floor on its own.*

6. Carefully lower the tank to the floor level.
7. Note that the tank is attached to the chassis by two pins. Lift up on the tank ends to separate and pull the tank free from the machine.



Caution: *Be careful not to crush or damage the drain hose when pulling the tank from the chassis.*



8. To reinstall the tank:
 - a. Align each side of the tank bracket with the chassis pins one at a time.
 - b. Grip the opening of the tank cover at the rear and quickly lift up to set (engage) the tank in its upright position.
 - c. Reconnect the **Tank Tether** to the back of the operator seat.
 - d. Swing the tank up to the vertical position to reengage the **Tank Latch**.
 - e. Reconnect the vacuum motor wiring connector and squeegee hose.

Vacuum Motor

1. Drain the recovery tank.
2. Release the **Tank Latch** and tilt the tank to the rear.

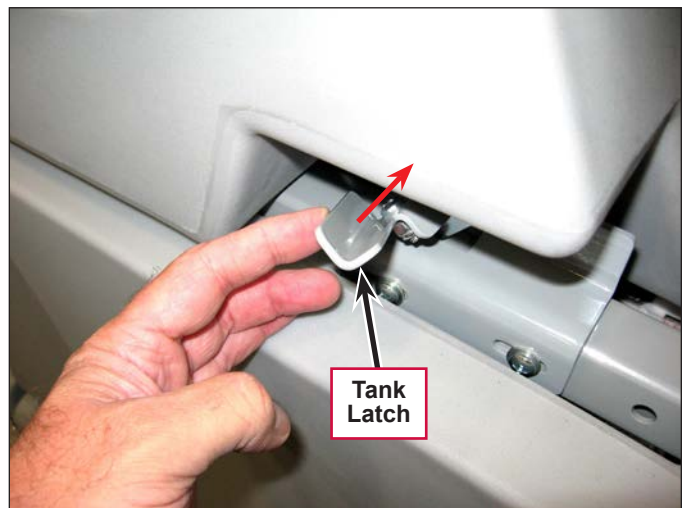

3. Remove the five **Screws** from the **Top Cover Assembly**, then lift the **Top Cover Assembly**, straight up while guiding the float cage up through the opening in the recovery tank.

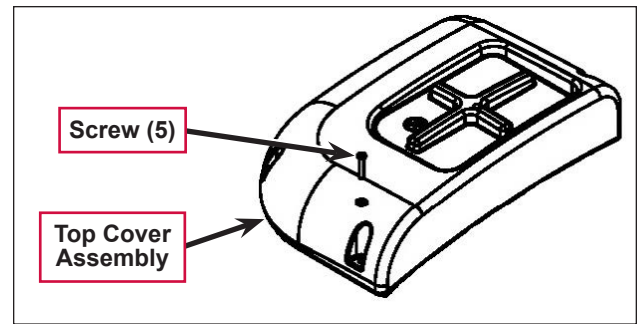

4. Disconnect the **Vacuum (exhaust) Hose** from the **Vacuum Motor**.
5. Disconnect the wiring harness connector from the **Vacuum Motor** and lift the **Vacuum Motor** out from its mounting cavity.
6. Inspect the following vacuum system gaskets and replace as necessary:

- **Vacuum Filter Lid Gasket**
- **Vacuum Fan Top Gasket**
- **RS Strip Gasket**
- **Vacuum Fan Gaskets**

7. Clean the vacuum motor **Filter**, **Filter Screen** and **Vacuum (exhaust) Hose**.
8. Inspect the carbon motor brushes. If the carbon brushes are less than 3/8" (10 mm) in length, replace the brushes.
9. Reinstall the **Vacuum Motor** by following the above steps in reverse order.

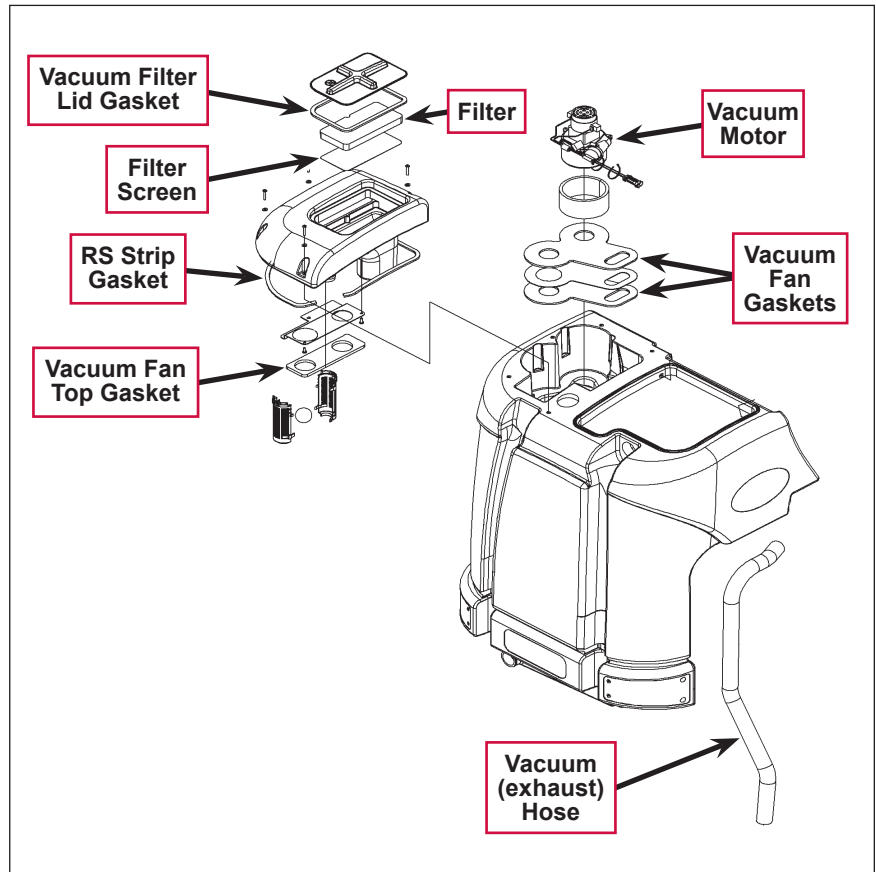

Specifications

Component	Specifications	
Vacuum Motor	36 VDC, Insulation Class: A	
Vacuum Lift	One Vacuum Motor	(Sealed) 68 in. H ₂ O
		(Open Hole Adapter 1") 14 in. H ₂ O
	Two Vacuum Motors	(Sealed) 74 in. H ₂ O
		(Open Hole Adapter 1") 27 in. H ₂ O

Special Tools

Vacuum water lift gauge, Nilfisk-Advance part number 56205281

Scrub System, Cylindrical

Functional Description

Overview

The Condor EcoFlex™ cylindrical scrub deck models use two cylindrical brushes that counter-rotate to sweep up light debris into a removable hopper, and scrub at the same time. The two scrub brushes are powered on opposing ends by 1-1/2 HP permanent-magnet motors and drive belts.

The scrub deck actuator raises and lowers the scrub deck, and automatically adjusts the deck height while scrubbing to maintain the desired scrub pressure.

Cylindrical Scrub System Wiring Diagram

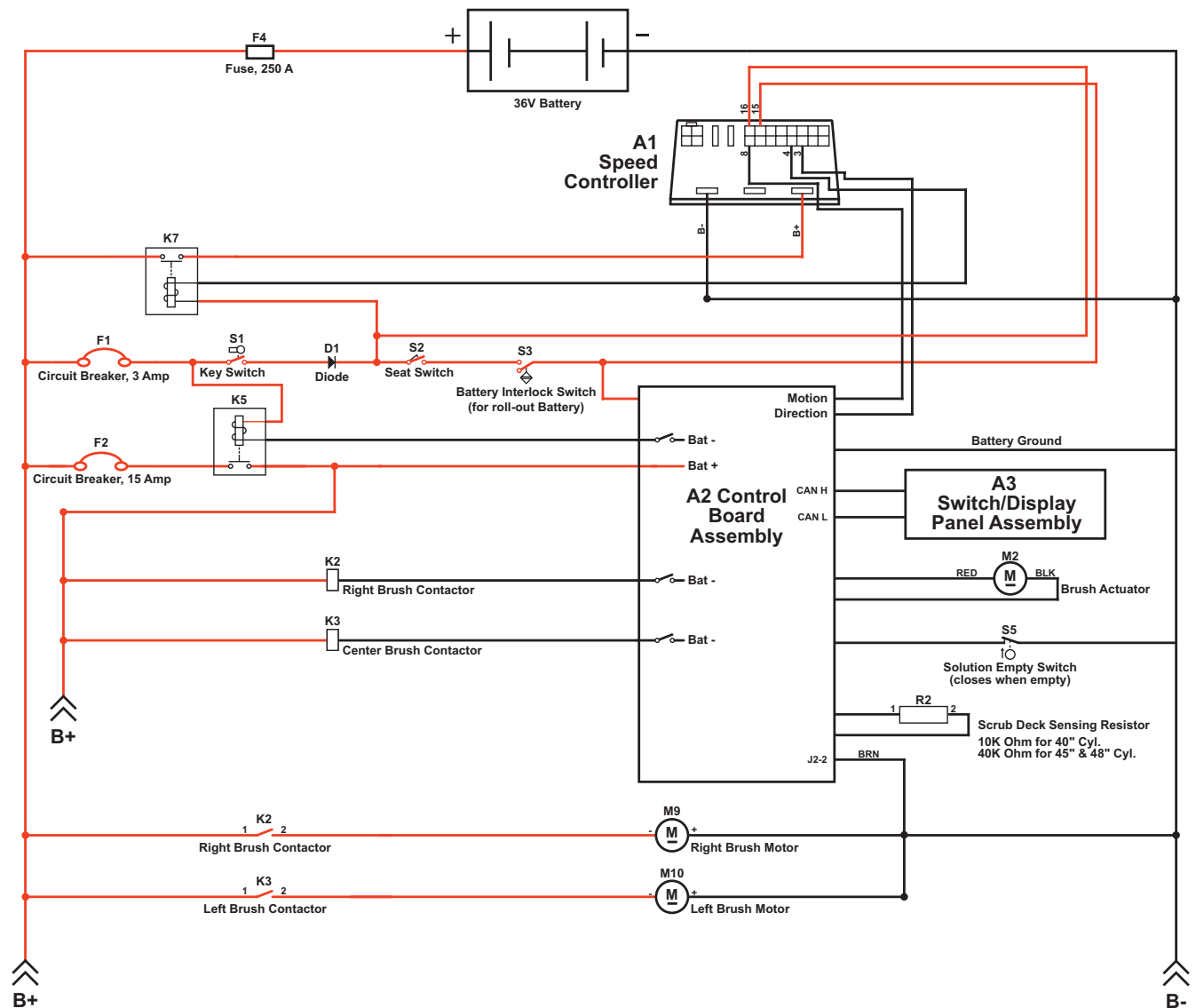

Circuit Description

The coil sides of contactors **K2** and **K3** get positive voltage from the **Battery** when the load side of contactor **K5** is closed. Contactor **K5** closes when the **A2 Control Board Assembly** connects the **K5** coil to battery ground. Contactors **K2** and **K3** are connected to battery ground through the **A2 Control Board Assembly**.

The **Right Brush Motor M9** and **Left Brush Motor M10** get positive voltage from the **Battery** when the load sides of contactors **K2** and **K3** are closed respectively. Contactors **K2** and **K3** close when the **A2 Control Board Assembly** connects the **K2** and **K3** coils to battery ground. The **Right Brush Motor M9** and **Left Brush Motor M10** are connected directly to battery ground.

The **Brush Actuator M2** gets voltage from the **A2 Control Board Assembly** which switches the polarity to move the scrub deck up or down. When the **A2 Control Board Assembly** receives a signal from the **A3 Switch/Display Panel Assembly** via the CAN BUS that the operator has pressed the scrub on switch, the **A2 Control Board Assembly** sends the appropriate voltage to the **Brush Actuator M2** to lower the scrub deck to the operating position.

The **Scrub Deck Sensing Resistor R2** senses the deck size so the operator does not need to program the deck size into the hidden menu.

As the brush motor current passes through the **BRN** current sense wire, which is in effect a low-value resistor, a small voltage drop is developed across it which is proportional to the motor current. This voltage change is inputted to pin **J2-2** on the **A2 Control Board Assembly**. Any surrounding temperature change in the **BRN** current sense wire affects its resistance, so the temperature is sensed by a thermistor built into the **A2 Control Board Assembly**. This allows error correction for the temperature resistance changes in the **BRN** current sense wire. When **A2 Control Board Assembly** senses a current draw out of the desired range it automatically turns on the **M2** actuator motor to raise or lower the scrub deck. This process is ongoing in maintaining the operator's selected scrub motor current load setting to sustain the desired brush working pressure.

Component Locations

The 1-1/2 HP permanent-magnet **Scrub Motors** drive **Poly V Sheaves** and **Drive Belts** that drive the broom drive lug assemblies coupled to the brushes.

The **Scrub Deck Actuator Assembly** raises and lowers the scrub deck and automatically adjusts the deck height during scrubbing to maintain the correct scrub pressure.

The **Hopper Assembly** holds the dust and debris swept up by the scrub brushes, and can be removed for dumping and cleaning.

The **Side Skirts** direct the waste water to the squeegee and help keep the water confined within the cleaning path. The **Side Skirt** height is adjustable, and the **Side Skirts** can be removed for cleaning or replacement.

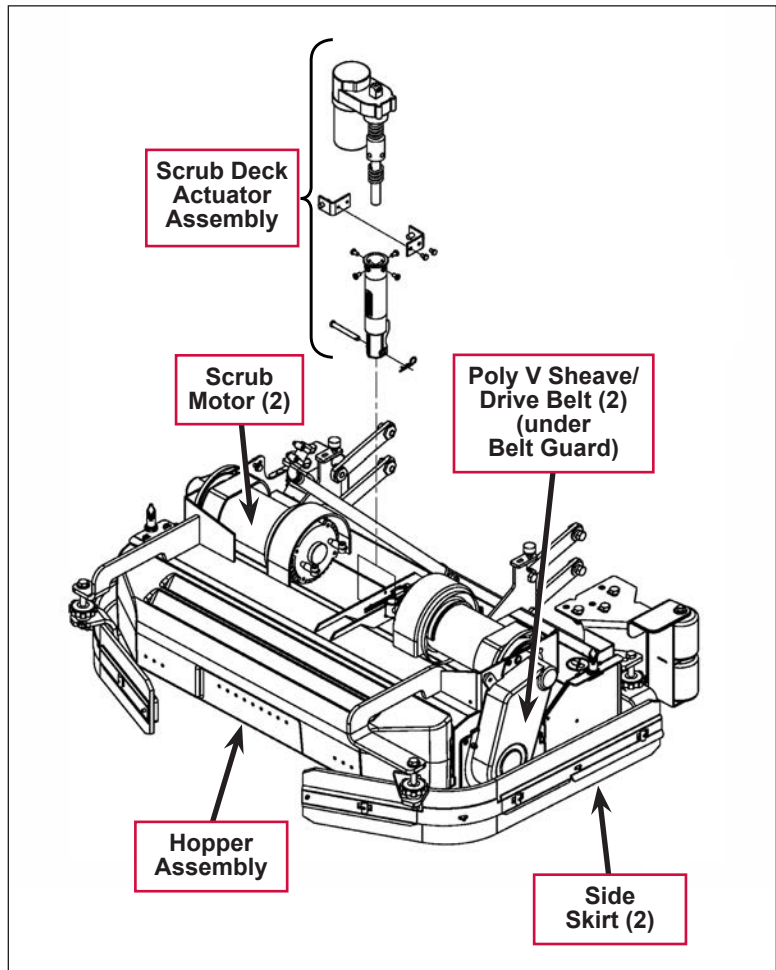

Maintenance and Adjustments



Warning! Before performing any machine maintenance or adjustments, make sure the key switch is off, the key is removed from the machine and the parking brake is engaged.

General Scrub System Maintenance

The scrubbing system must be serviced at regular intervals to maintain good scrubbing performance. Follow the maintenance steps listed below.

Daily Maintenance

- Dump the sweeping debris from the hopper.
- Rinse and clean any built-up debris from the hopper drain holes.

Weekly Maintenance

- Clean the drain holes in the solution delivery trough on top of the scrub deck.
- Clean any built-up dirt from the inside of the scrub brush housing.
- Remove any string wrapped around the scrub brushes, drive hubs and idler hubs.
- Remove both the scrub brushes and rotate end-for-end. Refer to the **Removal and Installation/Scrub Brushes** section.

Monthly Maintenance

- Inspect the scrub brush bristles for wear, the brushes should be replaced when the bristle length is 1 inch (26 mm) or less.

Scrub Brush Belt Replacement

1. Remove the **Side Skirt Assembly** on the side needing belt replacement.
2. Remove the two hex nuts (10 mm socket) and Phillips screw holding the **Belt Guard**, then remove the **Belt Guard**.
3. Loosen the **Flat Head Screw** and **Hex Screw** holding the **Belt Idler Arm Assembly** in position to release the tension on the belt, then roll the belt off the pulleys to remove.
4. Install a new belt onto the pulleys.

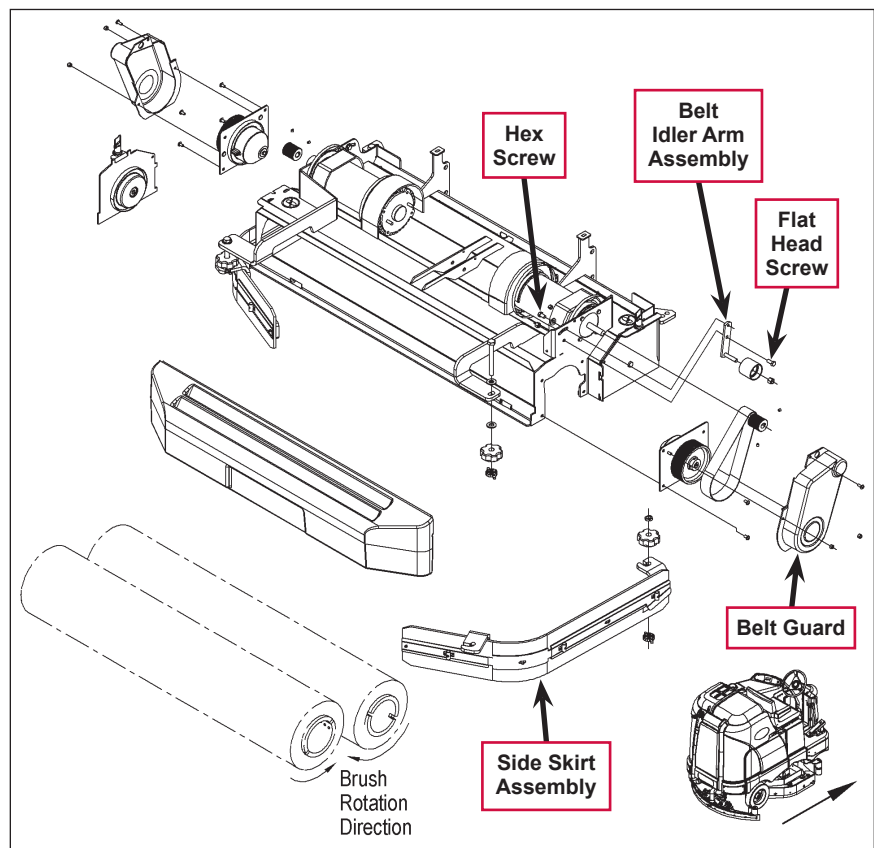

5. Rotate the 1" wide **Idler Arm** with an adjustable wrench so the **Idler Arm** is centered between the two holes drilled into the motor mount plate. This will provide a good preliminary tension setting.
6. Tighten the **Flat Head Screw**.
7. Remove the adjustable wrench from the **Idler Arm** and tighten the **Hex Screw** (shown in the figure on the preceding page).
8. Check for 1/8" deflection at the belt midpoint and make any additional belt tension adjustments as necessary. This will ensure the correct belt performance and belt/bearing life.
9. Reinstall the **Belt Guard** and **Side Skirt Assembly**, then test the scrub system for correct operation.

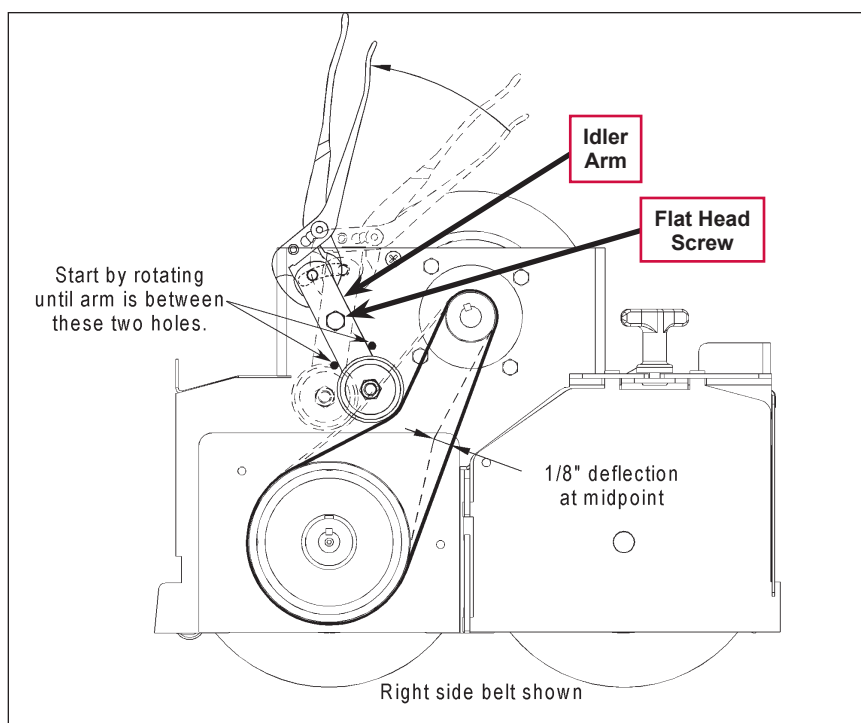

Lift Actuator Adjustment

This section explains the steps for adjusting the actuator drive nut (**Spring Housing Assembly**) setting for the scrub deck actuator motor.

Using the Actuator Power Cord Adapter

The adjacent drawing shows the special actuator power cord adapter (p/n 56407502) that is needed to connect the machine's battery pack and actuator motor for setting the actuator drive nut limit settings. To connect the actuator power cord adapter:

1. Open the machine battery compartment and disconnect the battery connector. The battery pack is needed to power the scrub deck actuator motor to correctly set the **IN** and **OUT** limit switches.
2. Connect the actuator motor to be tested to the power cord adapter end.
3. Connect the alligator clips from the cord adapter (red clip to the positive and black to negative) to battery connector or battery posts. Use the rocker switch on the actuator power cord adapter to change the motor rotation when setting the correct actuator drive nut dimensions.

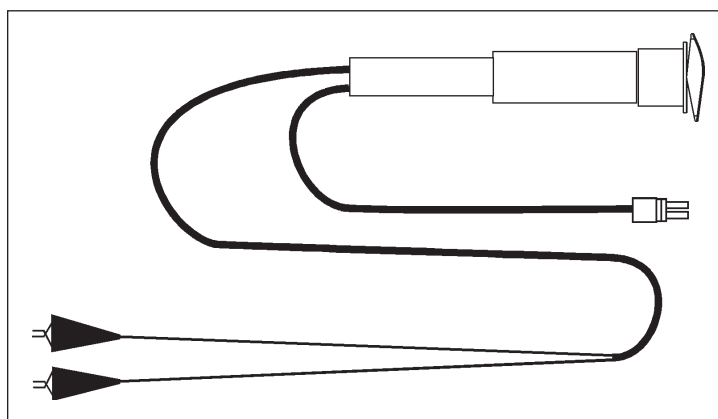



Service Note: You can also use the above actuator power cord adapter to help position the drive nut/spring housing assembly (in or out) for ease in actuator motor installations.

Drive Nut Adjustment

1. • If you're installing a new scrub deck actuator motor, begin with step 2 below.
 - If you're adjusting the **Drive Nut** on the existing scrub deck actuator, skip to step 5 on the following page.
2. Remove (spin-off) the plastic **Drive Nut** and install the **Upper Housing Spring** onto the actuator lead screw shaft.
3. Reinstall the **Drive Nut** as shown with the nut pin pocket away from the motor.
4. Assemble the **Lower Housing Spring**, **Spring Housing**, **Nut Retainer** (two-piece) and mounting hardware.

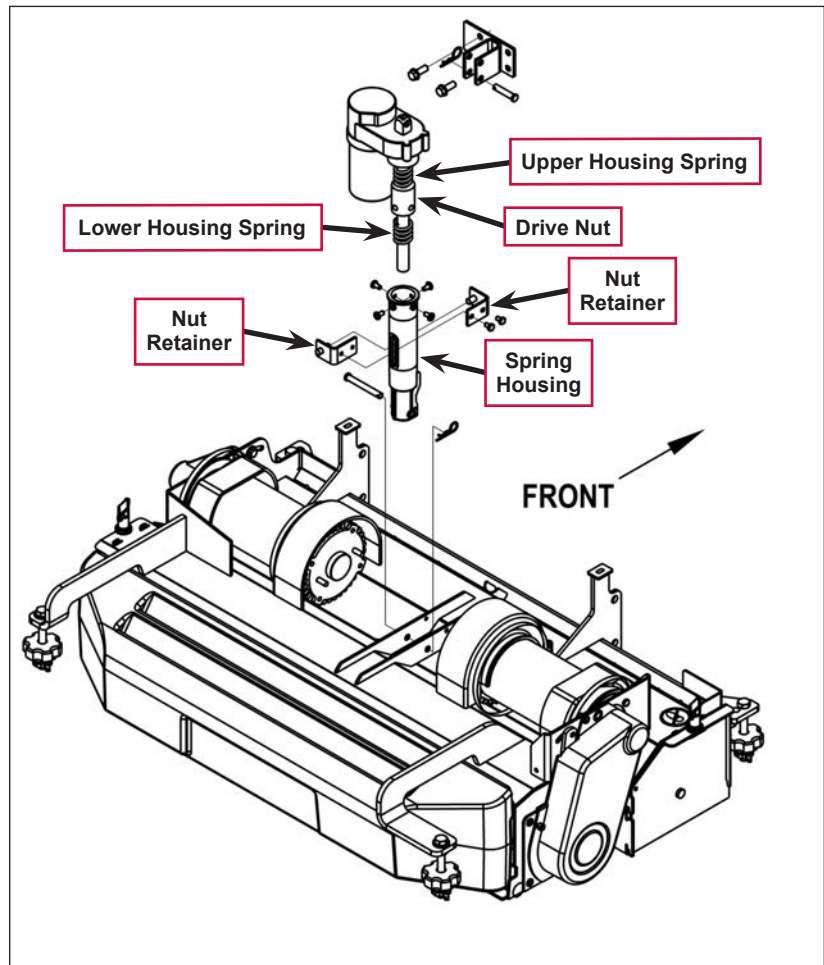

5. Hold onto the **Spring Housing Assembly** and press the rocker switch on the actuator power cord adapter to run the drive motor and retract the **Spring Housing Assembly** toward the motor housing (its **Retracted** limit).
6. Measure the position of the **Spring Housing Assembly** on the actuator shaft. Manually turn the **Spring Housing Assembly** to the appropriate **Retracted** position shown in the table below.

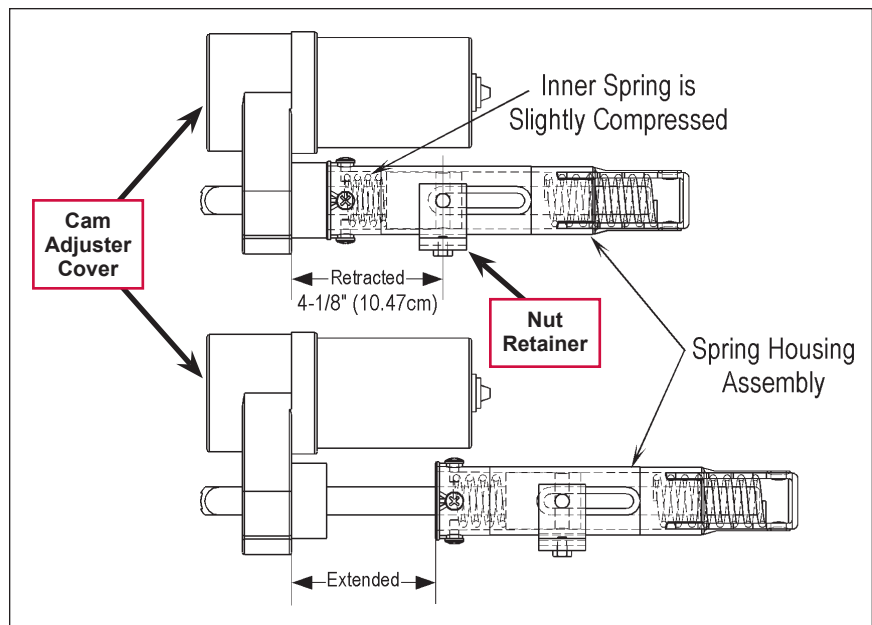

Service Note: The **Inner Spring** (upper housing spring) is set at a pre-loaded compressed setting. It will be necessary to slightly override the manual adjustment after running the **Spring Housing Assembly** in and turning it by hand. A small problem is observed in the retracted position as the pin mounting bracket interferes with the motor.

Part #	Actuator Motor	Spring Housing Retracted Position	Spring Housing Extended Position	Models
56413700	Scrub Brush Lift*	4-1/8" [10.48cm]	4" [10.16cm]	All

* The **Retracted** dimension reference point is the edge of the gearbox case to the center pin weldment of the assembled **Nut Retainer**. The **Extended** dimension reference point is the edge of the gearbox to the edge of the plastic **Spring Housing Assembly** as shown in the above drawing.



Note: All adjustment settings are measured out of the machine (not attached).

7. After making the initial adjustment, hold the **Spring Housing Assembly** and run it out enough so that the **Nut Retainer** can be turned in to make up difference from the dimension targeted. For example: the first **Retracted** dimension measures 4-1/2" minus the 4-1/8 target dimension the difference is 3/8". Turn the **Spring Housing Assembly** manually 3/8", then run the **Spring Housing Assembly** in under power until the inner limit stops the motor. Readjust until the **Retracted Position** is as shown in the above table.
8. Hold the **Spring Housing Assembly**, then press the rocker switch on the actuator power cord adapter to run the drive motor to the **Extended** position (wait until the motor stops).
9. Measure the position of the **Spring Housing Assembly** on the shaft and compare the measurement with the **Extended** position shown in the above table.
10. If the measurement doesn't match the dimension shown in the table, remove the **Cam Adjuster Cover** and adjust the **Extended** position as follows:
 - To *increase* the travel of the spring housing assembly, turn the adjuster *clockwise*.
 - To *decrease* the travel of the assembly, turn the adjuster *counterclockwise*.



Note: Use a 1/2" (13mm) socket to turn the adjuster. Each click of the adjuster will change the spring housing assembly travel 1/16 inch (1.6mm).

11. After each adjustment, hold the **Spring Housing Assembly**, run the actuator in and out and check both dimensions.
12. After checking that the **Spring Housing Assembly** limits are set correctly, replace the **Cam Adjuster Cover**.
13. After adjusting the actuator **Spring Housing Assembly** dimensions, refer to the **Removal and Installation/Scrub Deck Lift Actuator** section to reassemble it in the machine. Refer to the adjacent drawing to correctly mount the top of actuator motor to the chassis by model size.

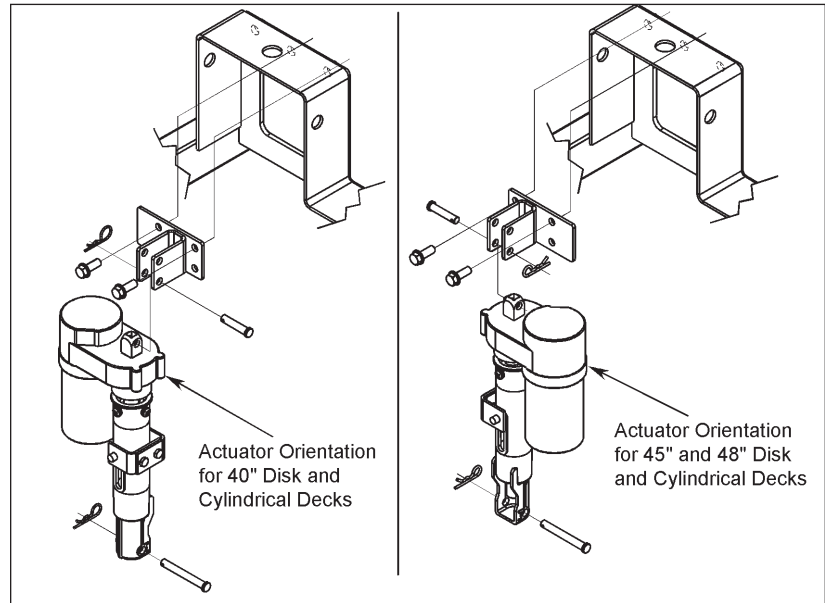

Service Note: Note the correct orientation of the **Spring Housing Assembly** when installing the complete motor assembly and also run the **Spring Housing Assembly** to the **Retracted (in)** position before you install it in the machine.

Side Skirt Replacement and Adjustment

During normal use the side skirt blades will wear in time. The operator will notice a small amount of water leaking out underneath the side skirts. You can easily adjust the side skirt height to lower the blades to allow the squeegee to pick up the water more effectively.

To reverse or replace the scrub system side skirt blade(s):

1. Loosen the two side skirt **Retainer Knobs** (two per side) and remove the **Side Skirt Assemblies** from the scrub deck. Remove the **Side Skirt Assemblies** by first sliding them forward, then pulling them off.
2. Remove all the hardware that holds the **Skirt Blades** to the **Bracket Weldments**. Note that the **Skirt Blade** is held on with tool-less retainers. Simply loosen the large **Thumb Nuts**, then turn the **Knobs** on the outside of the **Skirt Strap** until they are horizontal, then push them through the slots.
3. The main **Skirt Blade** has four working edges as shown. Turn the **Skirt Blade** so a clean, undamaged edge faces toward the center of the machine. Replace the **Skirt Blades** as a set if all four edges are nicked, torn or worn beyond their ability to be adjusted.
4. Reinstall the **Side Skirt Assemblies** onto the machine and check the height of the **Skirt Blades** for correct contact on the floor when the brush deck is lowered to the scrub position. The **Skirt Blades** should fold over just enough when scrubbing that all the waste water is contained inside the skirting. If necessary, adjust the height of the **Side Skirt Assemblies** as follows:

- a. Loosen the **Retainer Knobs**.
- b. Rotate the **Height Adjusting Knobs** to raise or lower the **Side Skirt Assembly** as necessary.

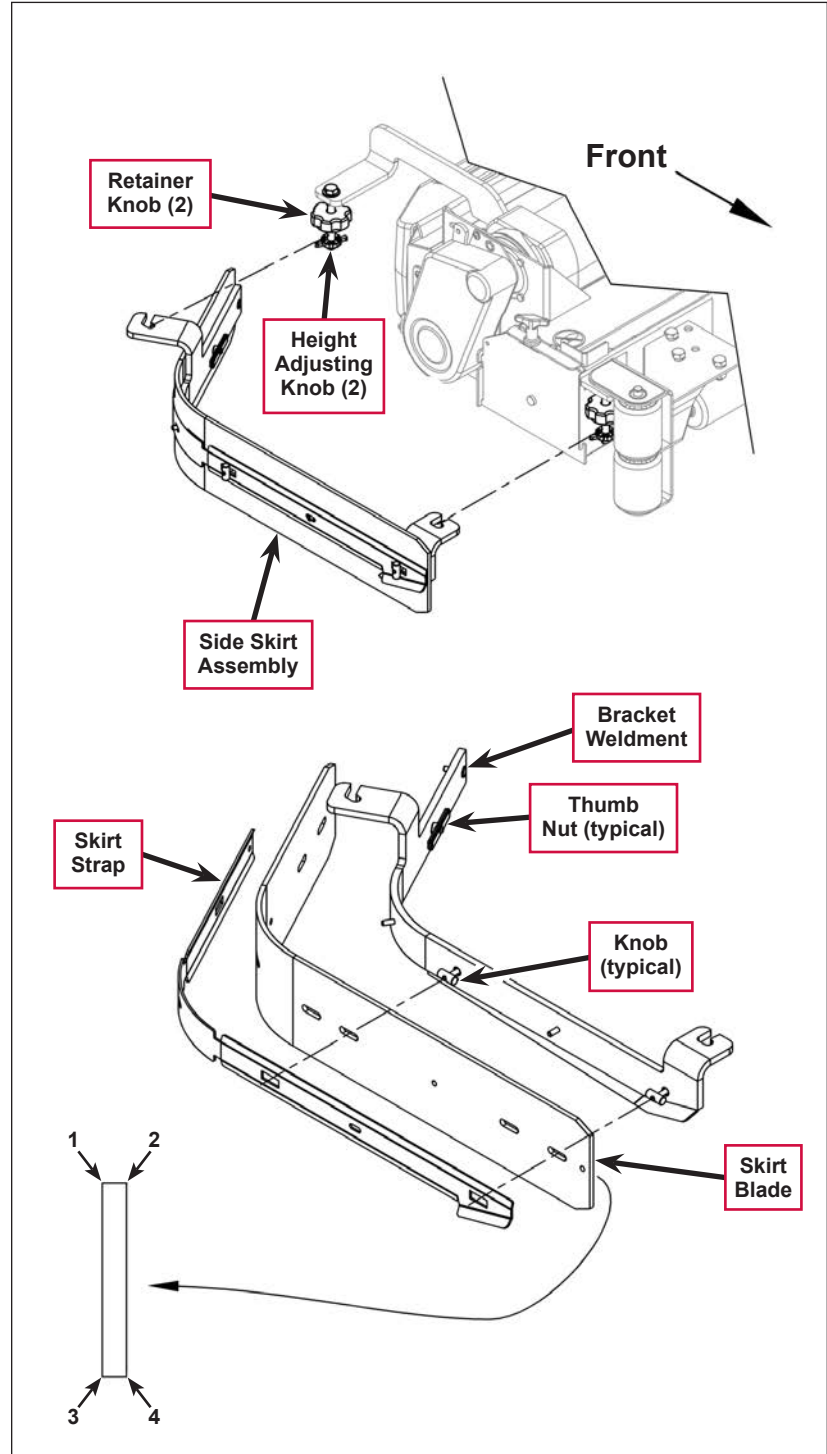

Note: Make small adjustments to obtain good blade wiping. Do not lower the blades too much to where they fold over excessively as this can cause excessive blade wear.

- c. When the **Skirt Blade** contact is correct, tighten the **Retainer Knobs**.

Troubleshooting

Problem	Cause	Correction
The scrub system will not operate	Scrub deck sense R2 resistor fault (error code 01 displayed)	<p>Scrub deck sensor resistor is unplugged or damaged.</p> <ol style="list-style-type: none"> 1. Check the resistor wiring for an open. 2. Substitute a new resistor and test the scrub deck for correct operation. <p>Note that there are four different resistor values used on the different deck types. See the electrical diagram decal for the correct specification of the resistor to replace.</p>
	Scrub motor overload (error code 04 displayed)	<ol style="list-style-type: none"> 1. Check for binding in the rotation of the brushes and incorrect brush deck lift actuator operation. 2. Check the negative supply cable at the brush motor for a wiring problem, and also the small BRN current sense wire in the harness and A2 pin J2-2. 3. Check for a short circuit in the brush motor or wiring. Check for excessive belt tension and the condition of the idler bearing.
	Center brush motor contactor coil overload (error code 06 displayed)	<ol style="list-style-type: none"> 1. Check for a K3 coil wiring problem or a short circuit (wire colors VIO and WHT/VIO). 2. Check the coil resistance. If the resistance is below 75 ohms, replace the coil. <p>Note that the nominal coil resistance is 94 ohms for both motor contactors.</p>
	Right brush motor contactor coil overload (error code 07 displayed)	<ol style="list-style-type: none"> 1. Check for a K2 coil wiring problem or a short circuit* (wire colors VIO & YEL/BLU). 2. Check the coil resistance. If the resistance is below 75 ohms, replace the coil.
	Scrub motor open (error code 21 displayed)	<ol style="list-style-type: none"> 1. Check for an open circuit in the motor wiring or for a defective motor. 2. Check for 36 volts at the scrub motor that is not running. If you get 0 Volts, replace the brush motor contactor.
	Center brush motor contactor coil open (error code 24 displayed)	<ol style="list-style-type: none"> 1. Check for an open circuit in the K3 coil and wiring (wire colors VIO and WHT/VIO). 2. Test for 36V at the K3 coil. If you get 0 Volts, check the A2 control board assembly.
	Center brush motor contactor coil short to ground (error code 25 displayed)	<ol style="list-style-type: none"> 1. Disconnect the K3 coil wiring (wire colors VIO and WHT/VIO) and check to see if the code disappears. <ul style="list-style-type: none"> – If the code disappears, replace the brush contactor. – If the code does reappear, test the wiring for a short back to the battery ground. Repair or replace the defective wire. 2. If the above test doesn't remove the code, substitute a new A2 control board assembly.

Problem	Cause	Correction
The scrub system will not operate (continued)	Right brush motor contactor coil open (error code 26 displayed)	<ol style="list-style-type: none"> 1. Check for an open circuit in the K2 coil and wiring (wire colors VIO and YEL/BLU). 2. Test for 36V at the K2 coil. If you get 0 Volts, check the A2 control board assembly.
	Right brush motor contactor coil short to ground (error code 27 displayed)	<ol style="list-style-type: none"> 1. Disconnect the K2 coil wiring (wire colors VIO and YEL/BLU) and check to see if the code disappears. <ul style="list-style-type: none"> – If the code disappears, replace the brush contactor. – If the code does reappear, test the wiring for a short back to the battery ground. Repair or replace the defective wire. 2. If the above test doesn't remove the code, substitute a new A2 control board assembly.
The scrub deck actuator doesn't raise or lower the scrub deck	<p>Scrub deck actuator overload (error code 08 displayed)</p> <ul style="list-style-type: none"> • Normal current load is 1-3 amps. • Max current load is 6 amps. • Max current with no load is 1.4 amps. 	<ol style="list-style-type: none"> 1. Check for binding or a frozen brush lift linkage and excessive weight on the brush deck. 2. Check for a short circuit in the actuator motor and wiring. Repair or replace. <p>To test the actuator, disconnect the motor plug and attach the actuator power cord adapter (p/n 56407502) and perform an amp draw test. Compare readings to the current load specifications to the left.</p>
	Scrub deck actuator open (error code 28 displayed)	<ol style="list-style-type: none"> 1. Check for disconnected lift actuator wiring. 2. Check for an open circuit in the motor wiring or for a defective motor. 3. Check for output voltage from the A2 control board assembly at the actuator wiring plug. It should be 36 volts. If 0 Volts, check the A2 control board assembly.

Removal and Installation



Warning! Before removing or reinstalling any machine components, make sure the key switch is off, key is removed from the machine and the parking brake is engaged.

Scrub Brushes

1. Make sure the scrub deck is in the *raised* position and the key switch is off.
2. Loosen the **Retainer Knobs**, then slide the **Side Skirt Assembly** forward slightly, then off of the scrub deck.
3. Loosen the **Thumb Nut** on top of the **Broom Idler Assembly** until the **Broom Idler Assembly** drops down far enough to disengage it from the **Notches**, then remove the **Broom Idler Assembly**.
4. Remove the **Brush** from the housing.
5. To reinstall a **Brush**, slide it into the housing, lift it slightly, then push and turn the **Brush** until it seats.
6. Reinstall the **Broom Idler Assembly** and **Side Skirt Assembly**.

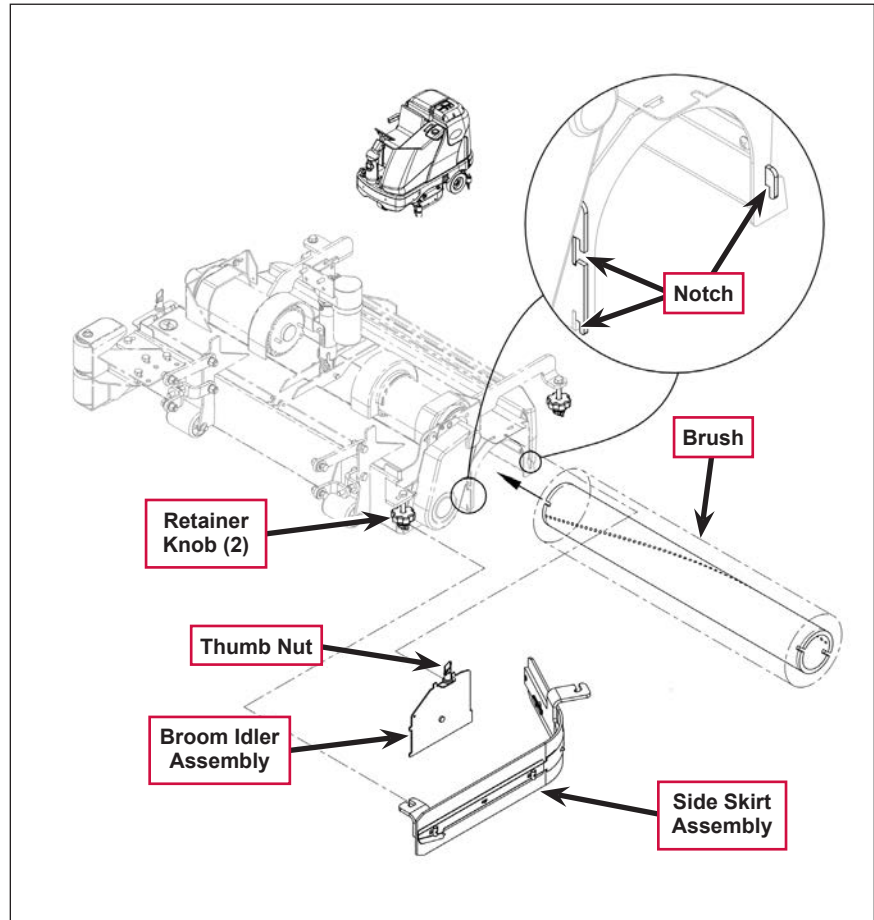

Scrub Brush Deck



Warning! Engage the parking brake and chock both rear wheels so the machine can't roll.

1. Loosen the four side skirt **Retainer Knobs** (two per side) and remove the **Side Skirt Assemblies** from the deck.
2. Slide out the **Hopper**.
3. With the scrub brushes installed in the deck, press the Scrub On button to lower the deck to the floor.

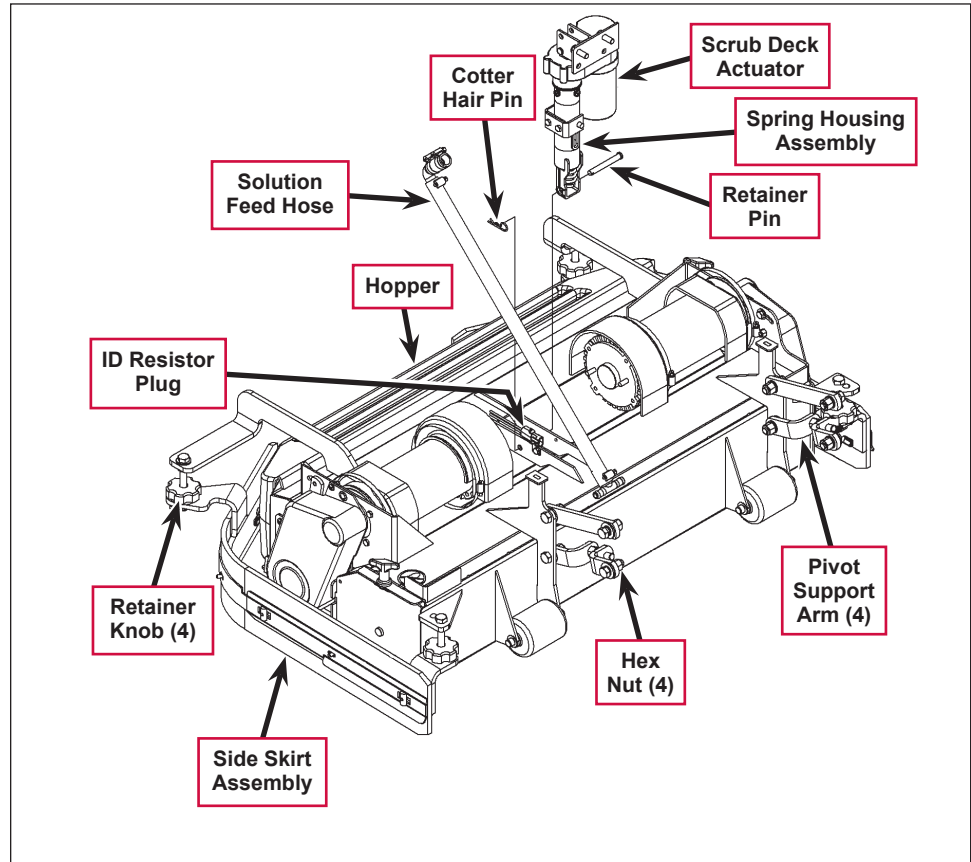

Service Note: Once the brush deck is in the lowered position, don't turn the key switch off until you disconnect the battery pack (push in the Emergency Disconnect). This will prevent the scrub deck from automatically rising when the key is turned off.

4. Turn the key switch off.
5. Remove the **Solution Feed Hose** at the solution solenoid valve located underneath the left side of the machine ahead of the rear wheel.
6. Remove bottom lift actuator **Cotter Hair Pin**, then push the **Retainer Pin** from its housing and mount bracket holes.
7. Disconnect the actuator wire harness connector. Note that this will prevent the actuator from being switched on and rising when it is disconnected from its deck mount.



Service Note: Connect the Advance power cord adapter (p/n 56407502) to the lift motor harness, then position (relieve the pressure on) the **Retainer Pin** for ease of removal.

8. Note the correct brush motor wire connections at each individual motor, then remove all the wiring from the motor terminals.
9. Locate the **ID** (identification) **Resistor Plug** on the scrub brush deck and separate its connector.

10. Remove the four **Hex Nuts**, hex screws and bushings from the left and right front deck supports, then swing the **Pivot Support Arms** away from their mounting holes.



Service Note: Removing both the left and right side brooms and both front chassis corner rollers will allow easier access to the mounting hardware on the four front scrub deck support arms.



Warning! Safely jack up the front of the machine 1-1/2 to 2 inches (38-50 mm) and put a wood block (2 x 4) underneath the drive wheel for a safety support.

11. Run the **Scrub Deck Actuator** to its retracted (up) position to get the clearance needed to pull the scrub deck assembly out from underneath the machine.



Service Note: Connect the power cord adapter (p/n 56407502) to the actuator motor and use the adapter to shorten the **Scrub Deck Actuator** length. Hold the **Spring Housing Assembly** when you run the **Scrub Deck Actuator** motor to maintain the correct retracted and extended position settings. See the **Lift Actuator Adjustment** section in this manual for additional details.

An alternate method to get the needed actuator clearance to slide the deck out from under the machine would be to safely jack up the front of the machine.



Warning! Support both front corners with adequate jack stands or blocking before working underneath the machine.

12. Carefully slide the complete deck assembly out from underneath the machine from either side.



Note: Observe the position of the disconnected lift actuator housing and swing it to the rear to clear its mount bracket pocket.

Scrub Deck Lift Actuator



Note: All new replacement actuator motors are not shipped with the lift nut pre-adjusted for any specific machine model application.



Note: The scrub deck must be removed to access the top mount bracket on the scrub deck lift motor.

1. Remove the scrub deck by following the steps in the **Scrub Brush Deck** section.
2. Locate and remove the upper **Cotter Hair Pin** from underneath the middle of the machine.
3. Slide the actuator **Mount Pin** from the housing and frame mounting bracket holes allowing the motor to drop down completing its removal.
4. Refer to the **Drive Nut Adjustment** section for instructions on how to install a new drive nut and set the extended and retracted positions.
5. Install the scrub deck actuator by following the above steps in reverse order.

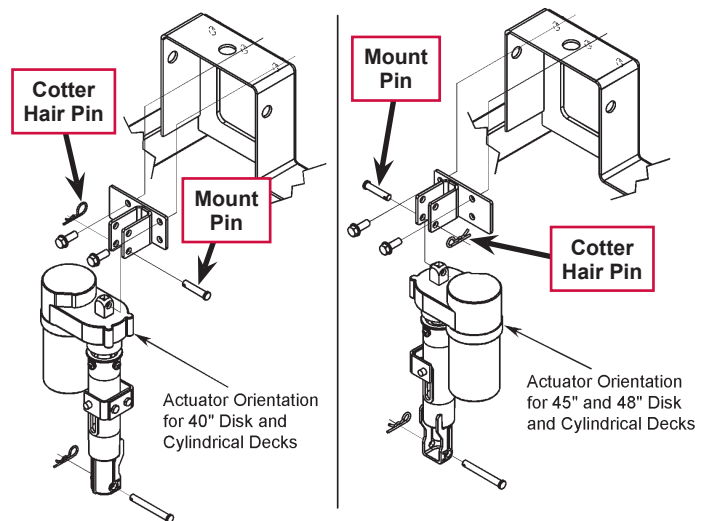

Service Note: You can use the actuator power cord adapter (p/n 56407502) to help position (extend or retract) the lift actuator housing for ease in installing the bottom **Mount (clevis) Pin**.

Scrub Brush Motor



Note: It is not necessary to remove the complete scrub deck assembly from the machine to service an individual scrub brush motor.

1. Remove the **Side Skirt Assembly** on the side of the deck that needs the scrub motor replaced.
2. Slide out the **Hopper**.
3. With the scrub brushes installed in the deck, press the Scrub On button to lower the deck to the floor.



Service Note: Once the brush deck is in the lowered position, don't turn the key switch off until you disconnect the battery pack (push in the Emergency Disconnect). This will prevent the scrub deck from automatically rising when the key is turned off.

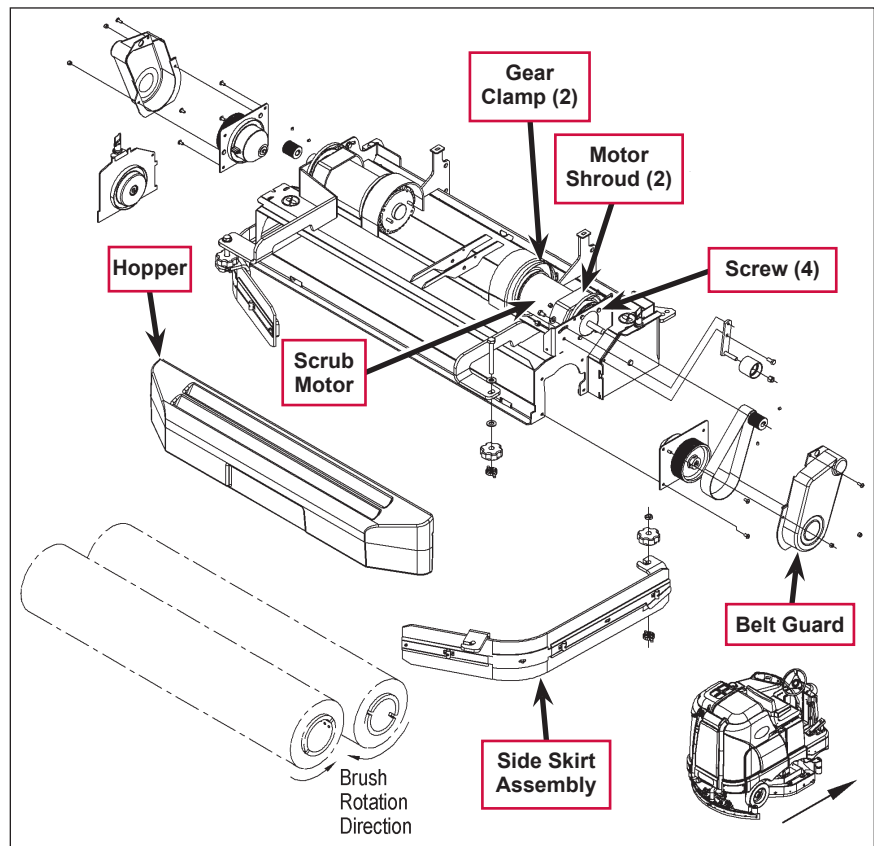

4. Turn the key switch off.
5. Loosen both worm **Gear Clamps** that fasten the inboard and outboard **Motor Shrouds** to the motor housing, then remove both **Motor Shrouds** from the motor.
6. Remove the two hex nuts (10 mm socket) and Phillips screw holding the **Belt Guard** and remove the **Belt Guard**.
7. Remove the four motor mount **Screws** holding the **Scrub Motor** to its deck mount. Also note that the **Scrub Motor** may stick to the motor mount, so be careful and watch your fingers as the motor will drop.
8. Turn the **Scrub Motor** clockwise to access the motor terminal studs. Note the wire connections for correct reassembly, then remove both motor wires.
9. Lower the deck assembly to the deck actuator's maximum down position (travel) to get the clearance needed to remove the motor from the machine. You can do this either of two ways:
 - Reconnect the battery, then lower the scrub deck in the service test mode. (Refer to the **Control System/Service Test Mode** section.)
 - Connect the actuator power cord adapter to the deck actuator motor and run (lower) the deck housing. (Refer to the **Drive Nut Adjustment** section for details.)
10. Pull and push the **Scrub Motor** back toward the rear of the machine to clear the chassis supports and remove it at the **Hopper**.

11. To install a Scrub Brush Motor:

- a. Follow the above steps in reverse order with the exception that the drive belt tension must be reduced to allow the installation of the four motor mount **Screws**.
- b. Refer to the **Scrub Brush Belt Replacement** section and follow the instructions on how to replace or tension the belt.

Specifications

Component	Specifications
Scrub Brush Motor	Voltage – 36 VDC
	Power – 1100 Watt
	Speed – 2200 RPM
	Current – 30 Amps
	UP Rating – 55
Deck Actuator Motor	Type – permanent magnet, 36 VDC, 1/5 HP, reversible
	Motor-to-drive-screw ratio – 19.1:1
	Performance Data
	No Load – Thrust 0 lbs., Speed 36 ±4 in/min, 1.0 ±0.5 Amps
	Full Load – Thrust 600 lbs., Speed 29 ±3 in/min, 5.0 ±1 Amps
	Stall Current – 25 Amps max.
	Start Thrust – 600 lbs. min.

Special Tools

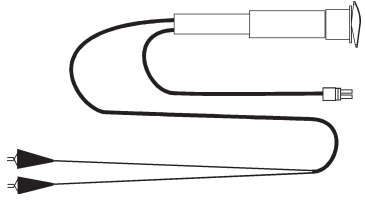
Actuator Power Cord Adapter, p/n 56407502	
---	---

Scrub System, Disc

Functional Description

Overview

The Condor EcoFlex™ disc models use rotary brushes powered by permanent-magnet motors and gearbox assemblies. The 40" decks have two scrub brushes that are both powered by one 3 HP motor/gearbox assembly. The 45" and 48" decks have three brushes, each powered by a separate 1-1/2 HP motor/gearbox assembly.

The scrub deck lift actuator raises and lowers the scrub deck, and automatically adjusts the deck height while scrubbing to maintain the desired scrub pressure.

Disc Scrub System Wiring Diagram

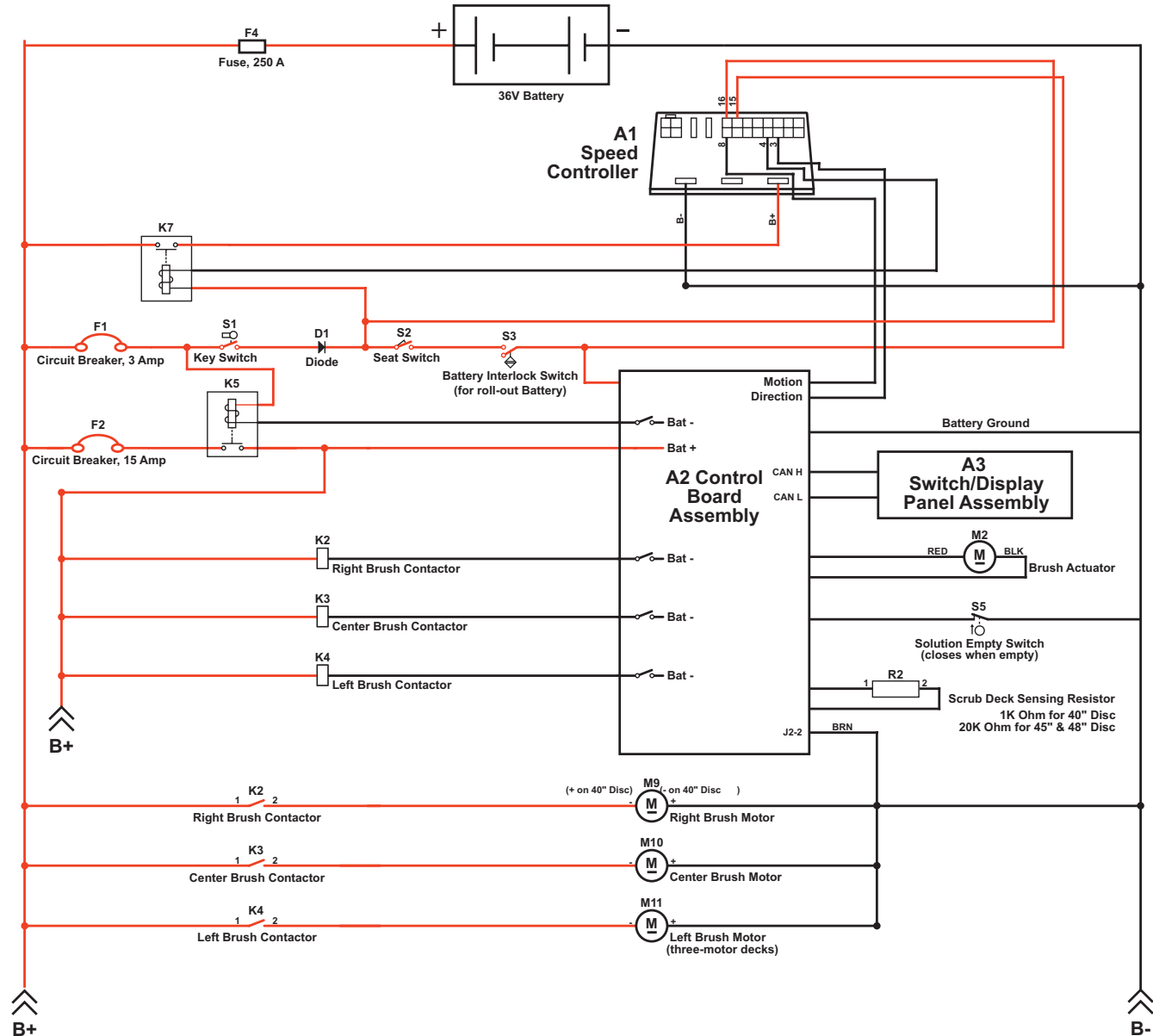

Circuit Description

The coil sides of contactors **K2, K3 and K4** get positive voltage from the **Battery** when the load side of contactor **K5** is closed. Contactor **K5** closes when the **A2 Control Board Assembly** connects the **K5** coil to battery ground. Contactors **K2, K3 and K4** are connected to battery ground through the **A2 Control Board Assembly**.

The **Right Brush Motor M9, Center Brush Motor M10** and **Left Brush Motor M11** get positive voltage from the **Battery** when the load sides of contactors **K2, K3 and K4** are closed respectively. Contactors **K2, K3 and K4** close when the **A2 Control Board Assembly** connects the **K2, K3 and K4** coils to battery ground. The **Right Brush Motor M9, Center Brush Motor M10** and **Left Brush Motor M11** are connected directly to battery ground.

The **Brush Actuator M2** gets voltage from the **A2 Control Board Assembly** which switches the polarity to move the scrub deck up or down. When the **A2 Control Board Assembly** receives a signal from the **A3 Switch/Display Panel Assembly** via the CAN BUS that the operator has pressed the scrub on switch, the **A2 Control Board Assembly** sends the appropriate voltage to the **Brush Actuator M2** to lower the scrub deck to the operating position.

The **Scrub Deck Sensing Resistor R2** senses the deck size so the operator does not need to program the deck size into the hidden menu.

As the brush motor current passes through the **BRN** current sense wire, which is in effect a low-value resistor, a small voltage drop is developed across it which is proportional to the motor current. This voltage change is inputted to pin **J2-2** on the **A2 Control Board Assembly**. Any surrounding temperature change in the **BRN** current sense wire affects its resistance, so the temperature is sensed by a thermistor built into the **A2 Control Board Assembly**. This allows error correction for the temperature resistance changes in the **BRN** current sense wire. When **A2 Control Board Assembly** senses a current draw out of the desired range it automatically turns on the **M2** actuator motor to raise or lower the scrub deck. This process is ongoing in maintaining the operator's selected scrub motor current load setting to sustain the desired brush working pressure.

Component Locations

On the 45” and 48” decks, three 1-1/2 HP **Gearmotors** drive the scrub brushes directly. The 40” decks have a single 3 HP **Gearmotor** with two gearboxes (one on either end) that power the two scrub brushes.

The **Scrub Deck Actuator Assembly** raises and lowers the scrub deck, and automatically adjusts the deck height during scrubbing to maintain the correct scrub pressure.

The **Side Skirts** direct the waste water to the squeegee and help keep the water confined within the cleaning path. The **Side Skirt** height is adjustable and the **Side Skirts** can be removed for cleaning or replacement.

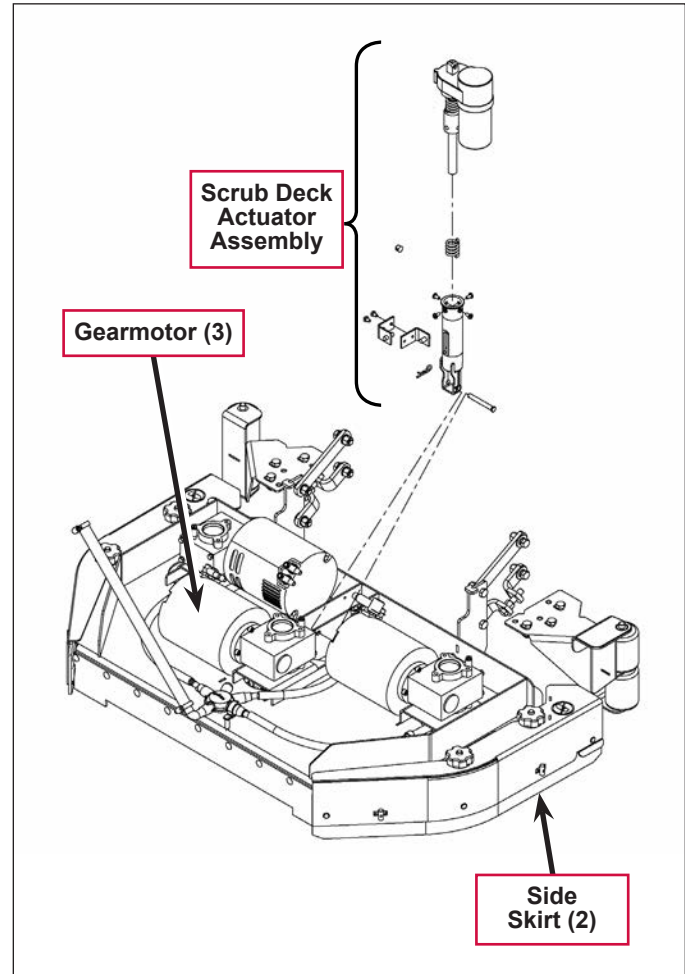

Maintenance and Adjustments



Warning! Before performing any machine maintenance or adjustments, make sure the key switch is off, the key is removed from the machine and the parking brake is engaged.

Lift Actuator Adjustment

This section explains the steps for adjusting the actuator drive nut (**Spring Housing Assembly**) setting for the lift actuator motor.

Using the Actuator Power Cord Adapter

The adjacent drawing shows the special actuator power cord adapter (p/n 56407502) that is needed to connect the machine's battery pack and actuator motor for setting the actuator drive nut limit settings. To connect the actuator power cord adapter:

1. Open the machine battery compartment and disconnect the battery connector. The battery pack is needed to power the lift actuator motor to correctly set the **IN** and **OUT** limit switches.
2. Connect the actuator motor to be tested to the power cord adapter end.
3. Connect the alligator clips from the cord adapter (red clip to the positive and black to negative) to battery connector or battery posts. Use the rocker switch on the actuator power cord adapter to change the motor rotation when setting the correct actuator drive nut dimensions.

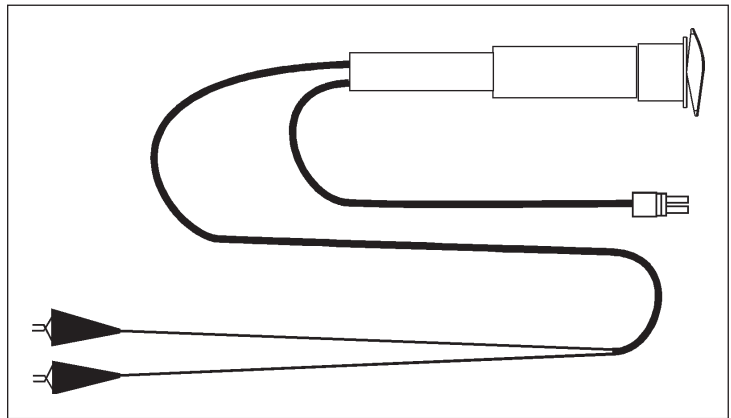

Service Note: You can use the above actuator power cord adapter to help position the drive nut/spring housing assembly (in or out) for ease in actuator motor installations.

Drive Nut Adjustment

- If you're installing a new scrub deck lift actuator motor, begin with step 2 below.
 - If you're adjusting the **Drive Nut** on the existing scrub deck lift actuator, skip to step 5 on the following page.
- Remove (spin-off) the plastic **Drive Nut** and install the **Upper Housing Spring** onto the actuator lead screw shaft.
- Reinstall the **Drive Nut** as shown with the nut pin pocket away from the motor.
- Assemble the **Lower Housing Spring, Spring Housing, Nut Retainer** (two-piece) and mounting hardware.

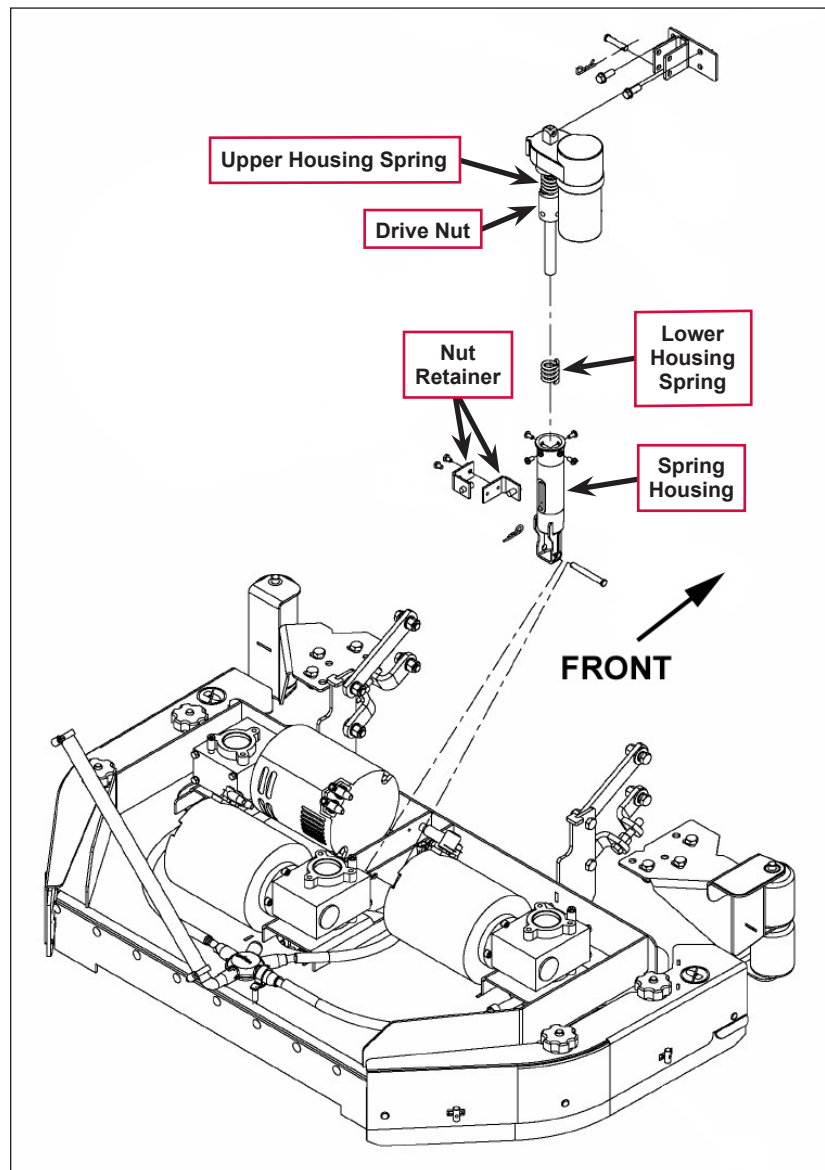

5. Hold onto the **Spring Housing Assembly** and press the rocker switch on the actuator power cord adapter to run the drive motor and retract the **Spring Housing Assembly** toward the motor housing (its **Retracted** limit).
6. Measure the position of the **Spring Housing Assembly** on the actuator shaft. Manually turn the **Spring Housing Assembly** to the appropriate **Retracted** position shown in the table below.

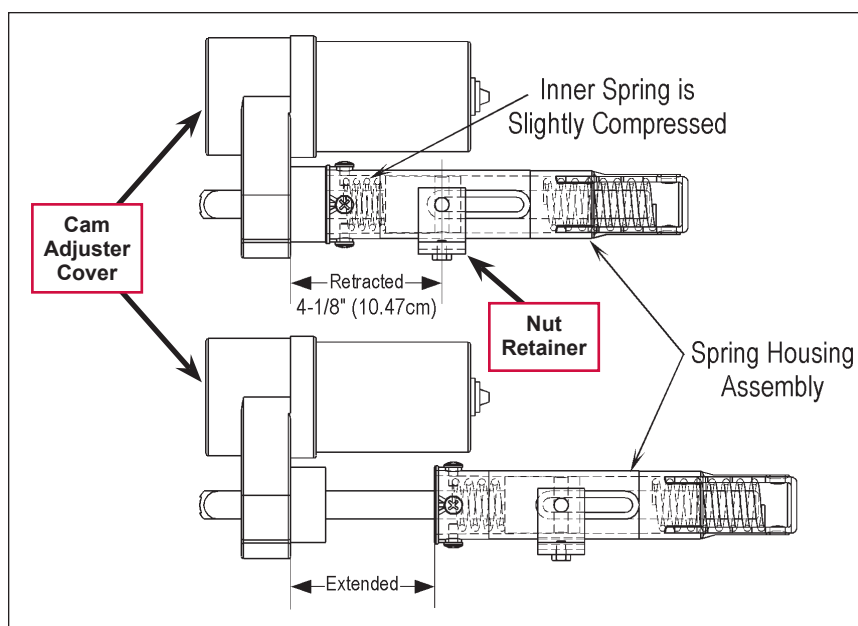

Service Note: The **Inner Spring** (upper housing spring) is set at a pre-loaded compressed setting. It will be necessary to slightly override the manual adjustment after running the **Spring Housing Assembly** in and turning it by hand. A small problem is observed in the retracted position as the pin mounting bracket interferes with the motor.

Part #	Actuator Motor	Spring Housing Retracted Position	Spring Housing Extended Position	Models
56413700	Scrub Brush Lift*	4-1/8" [10.48cm]	4" [10.16cm]	All

* The **Retracted** dimension reference point is the edge of the gearbox case to the center pin weldment of the assembled **Nut Retainer**. The **Extended** dimension reference point is the edge of the gearbox to the edge of the plastic **Spring Housing Assembly** as shown in the above drawing.



Note: All adjustment settings are measured out of the machine (not attached).

7. After making the initial adjustment hold the **Spring Housing Assembly** and run it out enough so that the **Nut Retainer** can be turned in to make up difference from the dimension targeted. For example: the first **Retracted** dimension measures 4-1/2" minus the 4-1/8 target dimension the difference is 3/8". Turn the **Spring Housing Assembly** manually 3/8", then run the **Spring Housing Assembly** in under power until the inner limit stops the motor. Readjust until the **Retracted Position** is as shown in the above table.
8. Hold the **Spring Housing Assembly**, then press the rocker switch on the actuator power cord adapter to run the drive motor to the **Extended** position (wait until the motor stops).
9. Measure the position of the **Spring Housing Assembly** on the shaft and compare the measurement with the **Extended** position shown in the above table.
10. If the measurement doesn't match the dimension shown in the table, remove the **Cam Adjuster Cover** and adjust the **Extended** position as follows:
 - To *increase* the travel of the spring housing assembly, turn the adjuster *clockwise*.
 - To *decrease* the travel of the assembly, turn the adjuster *counterclockwise*.



Note: Use a 1/2" (13mm) socket to turn the adjuster. Each click of the adjuster will change the spring housing assembly travel 1/16 inch (1.6mm).

11. After each adjustment, hold the **Spring Housing Assembly**, run the actuator in and out and check both dimensions.
12. After checking that the **Spring Housing Assembly** limits are set correctly, replace the **Cam Adjuster Cover**.
13. After adjusting the actuator **Spring Housing Assembly** dimensions, refer to the **Removal and Installation/Scrub Brush Lift Actuator** section to reassemble it in the machine. Refer to the adjacent drawing to correctly mount the top of lift motor to the chassis by model size.

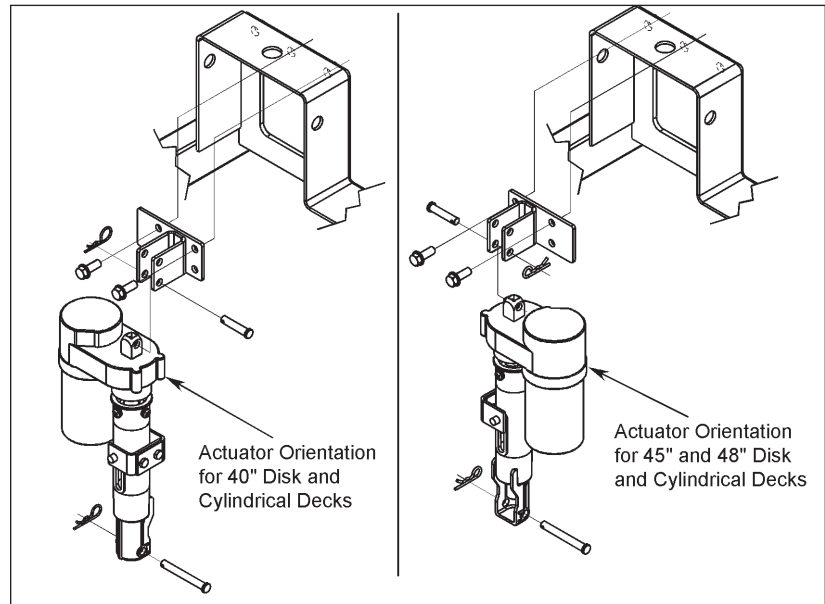

Service Note: Note the correct orientation of the **Spring Housing Assembly** when installing the complete motor assembly and also run the **Spring Housing Assembly** to the **Retracted** (in) position before you install it in the machine.

Side Skirt Replacement and Adjustment

During normal use the side skirt blades will wear in time. The operator will notice a small amount of water leaking out underneath the side skirts. You can easily adjust the side skirt height to lower the blades to allow the squeegee to pick up the water more effectively.

To reverse or replace the scrub system side skirt blade(s):

1. Loosen the two side skirt **Retainer Knobs** (two per side) and remove the **Side Skirt Assemblies** from the scrub deck. Remove the **Side Skirt Assemblies** by first sliding them forward, then pulling them off.
2. Remove all the hardware that holds the **Skirt Blades** to the **Skirt Weldments**. Note that the **Skirt Blade** is held on with tool-less retainers. Simply loosen the large **Thumb Nuts**, then turn the **Knobs** on the outside of the **Skirt Strap** until they are horizontal, then push them through the slots. The small **Inside Blade** is held on by two screws and nuts and has two working edges.
3. The main **Skirt Blade** has four working edges as shown. Turn the **Skirt Blade** so a clean, undamaged edge faces toward the center of the machine. Replace the **Skirt Blades** as a set if all four edges are nicked, torn or worn beyond their ability to be adjusted.
4. Reinstall the **Side Skirt Assemblies** onto the machine and check the height of the **Skirt Blades** for correct contact on the floor when the brush deck is lowered to the scrub position. The **Skirt Blades** should fold over just enough when scrubbing that all the waste water is contained inside the skirting. If necessary, adjust the height of the **Side Skirt Assemblies** as follows:

- a. Loosen the **Retainer Knobs**.
- b. Rotate the **Height Adjusting Knobs** to raise or lower the **Side Skirt Assembly** as necessary.

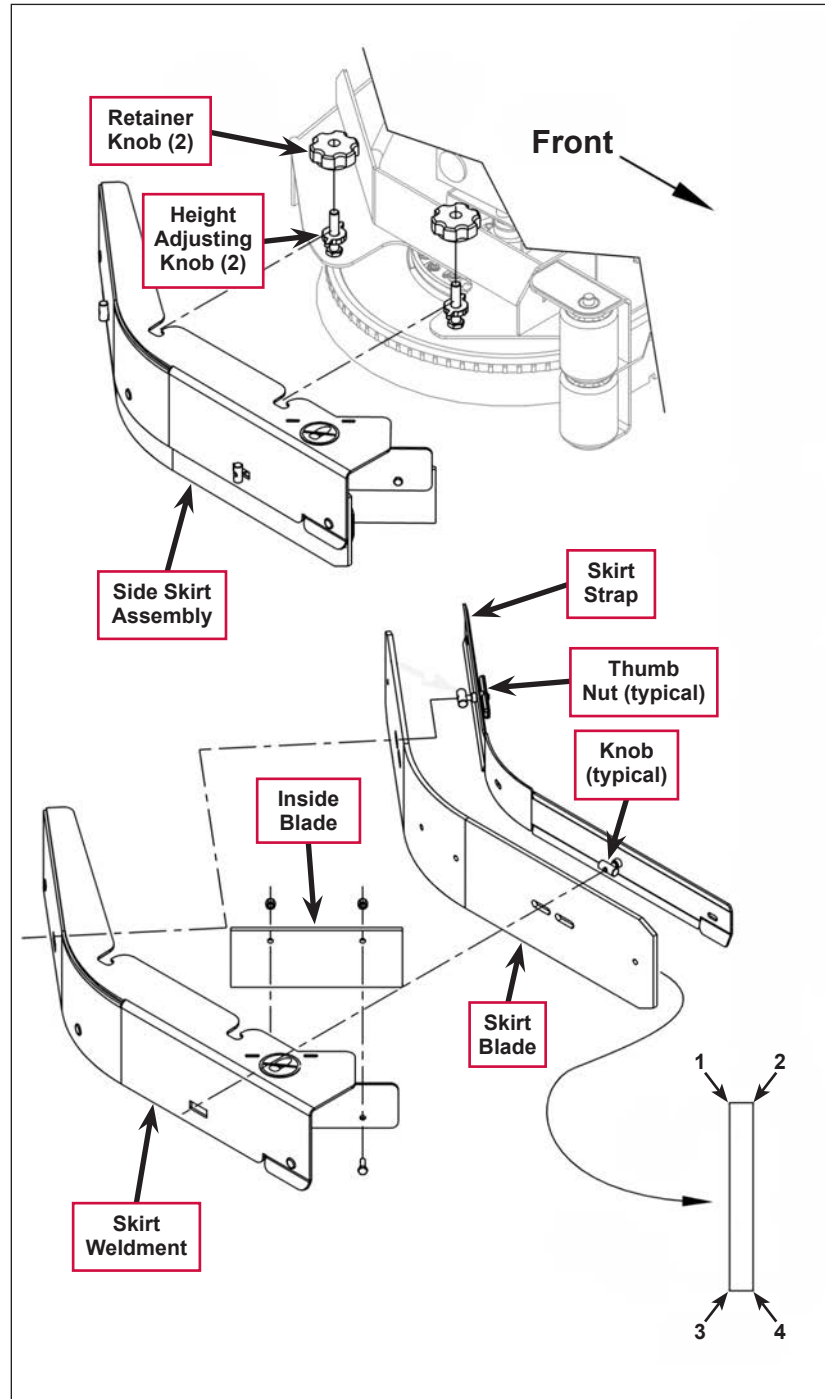

Note: Make small adjustments to obtain good blade wiping. Do not lower the blades too much to where they fold over excessively as this can cause excessive blade wear.

- c. When the **Skirt Blade** contact is correct, tighten the **Retainer Knobs**.

Troubleshooting

Problem	Cause	Correction
The scrub system will not operate	Scrub deck sense R2 resistor fault (error code 01 displayed)	<p>Scrub deck sensor resistor is unplugged or damaged.</p> <ol style="list-style-type: none"> 1. Check the resistor wiring for an open. 2. Substitute a new resistor and test the scrub deck for correct operation. <p>Note that there are four different resistor values used on the different deck types. See the electrical diagram decal for the correct specification of the resistor to replace.</p>
	Scrub motor overload (error code 04 displayed)	<ol style="list-style-type: none"> 1. Check for binding in the rotation of the brushes and incorrect brush deck lift actuator operation. 2. Check the negative supply cable at the brush motor for a wiring problem, and also the small BRN current sense wire in the harness and A2 pin J2-2. 3. Check for a short circuit in the brush motor or wiring. Check for excessive belt tension and the condition of the idler bearing.
	<p>Left brush motor contactor coil overload (error code 05 displayed)</p> <p>Contactor K4 is for the left motor on the three-motor decks.</p>	<ol style="list-style-type: none"> 1. Check for a K4 coil wiring problem or a short circuit* (wire colors VIO and GRA/RED). 2. Check the coil resistance. If the resistance is below 75 ohms, replace the coil. <p>Note that the nominal coil resistance is 94 ohms for all three motor contactors.</p>
	Center brush motor contactor coil overload (error code 06 displayed)	<ol style="list-style-type: none"> 1. Check for a K3 coil wiring problem or a short circuit (wire colors VIO and WHT/VIO). 2. Check the coil resistance. If the resistance is below 75 ohms, replace the coil.
	Right brush motor contactor coil overload (error code 07 displayed)	<ol style="list-style-type: none"> 1. Check for a K2 coil wiring problem or a short circuit* (wire colors VIO & YEL/BLU). 2. Check the coil resistance. If the resistance is below 75 ohms, replace the coil.
	Scrub motor open (error code 21 displayed)	<ol style="list-style-type: none"> 1. Check for an open circuit in the motor wiring or for a defective motor. 2. Check for 36 volts at the scrub motor that is not running. If you get 0 Volts, replace the brush motor contactor.

Problem	Cause	Correction
The scrub system will not operate (continued)	Left brush motor contactor coil open (error code 22 displayed)	<ol style="list-style-type: none"> 1. Check for an open circuit in the K4 coil and wiring (wire colors VIO and GRA/RED) 2. Test for 36V at the K4 coil. If you get 0 Volts, check the A2 control board assembly.
	Left brush motor contactor coil short to ground (error code 23 displayed)	<ol style="list-style-type: none"> 1. Disconnect the K4 coil wiring (wire colors VIO and GRA/RED) and check to see if the code disappears. <ul style="list-style-type: none"> – If the code disappears, replace the brush contactor. – If the code does reappear, test the wiring for a short back to the battery ground. Repair or replace the defective wire. 2. If the above test doesn't remove the code, substitute a new A2 control board assembly.
	Center brush motor contactor coil open (error code 24 displayed)	<ol style="list-style-type: none"> 1. Check for an open circuit in the K3 coil and wiring (wire colors VIO and WHT/VIO) 2. Test for 36V at the K3 coil. If you get 0 Volts, check the A2 control board assembly.
	Center brush motor contactor coil short to ground (error code 25 displayed)	<ol style="list-style-type: none"> 1. Disconnect the K3 coil wiring (wire colors VIO and WHT/VIO) and check to see if the code disappears. <ul style="list-style-type: none"> – If the code disappears, replace the brush contactor. – If the code does reappear, test the wiring for a short back to the battery ground. Repair or replace the defective wire. 2. If the above test doesn't remove the code, substitute a new A2 control board assembly.
	Right brush motor contactor coil open (error code 26 displayed)	<ol style="list-style-type: none"> 1. Check for an open circuit in the K2 coil and wiring (wire colors VIO and YEL/BLU) 2. Test for 36V at the K2 coil. If you get 0 Volts, check the A2 control board assembly.
	Right brush motor contactor coil short to ground (error code 27 displayed)	<ol style="list-style-type: none"> 1. Disconnect the K2 coil wiring (wire colors VIO and YEL/BLU) and check to see if the code disappears. <ul style="list-style-type: none"> – If the code disappears, replace the brush contactor. – If the code does reappear, test the wiring for a short back to the battery ground. Repair or replace the defective wire. 2. If the above test doesn't remove the code, substitute a new A2 control board assembly.

Problem	Cause	Correction
The scrub deck actuator doesn't raise or lower the scrub deck	Scrub deck actuator overload (error code 08 displayed) <ul style="list-style-type: none"> • Normal current load is 1-3 amps. • Max current load is 6 amps. • Max current with no load is 1.4 amps. 	<ol style="list-style-type: none"> 1. Check for binding or a frozen brush lift linkage and excessive weight on the brush deck. 2. Check for a short circuit in the actuator motor and wiring. Repair or replace. <p>To test the actuator, disconnect the motor plug and attach the actuator power cord adapter (p/n 56407502) and perform an amp draw test. Compare readings to the current load specifications to the left.</p>
	Scrub deck actuator open (error code 28 displayed)	<ol style="list-style-type: none"> 1. Check for disconnected lift actuator wiring. 2. Check for an open circuit in the motor wiring or for a defective motor. 3. Check for output voltage from the A2 control board assembly at the actuator wiring plug. It should be 36 volts. If 0 Volts, check the A2 control board assembly.

Removal and Installation



Warning! Before removing or reinstalling any machine components, make sure the key switch is off and the key is removed from the machine.

Scrub Brush Deck



Warning! Engage the parking brake and chock both rear wheels so the machine can't roll.

1. Loosen the four side skirt **Retainer Knobs** (two per side) and remove the **Side Skirt Assemblies** from the deck.
2. Remove the scrub brushes from the brush holders.
3. Place wood blocking (2x4) under both outside brush drive discs (brush holders) and lower the deck to the floor by pressing the Scrub On button.

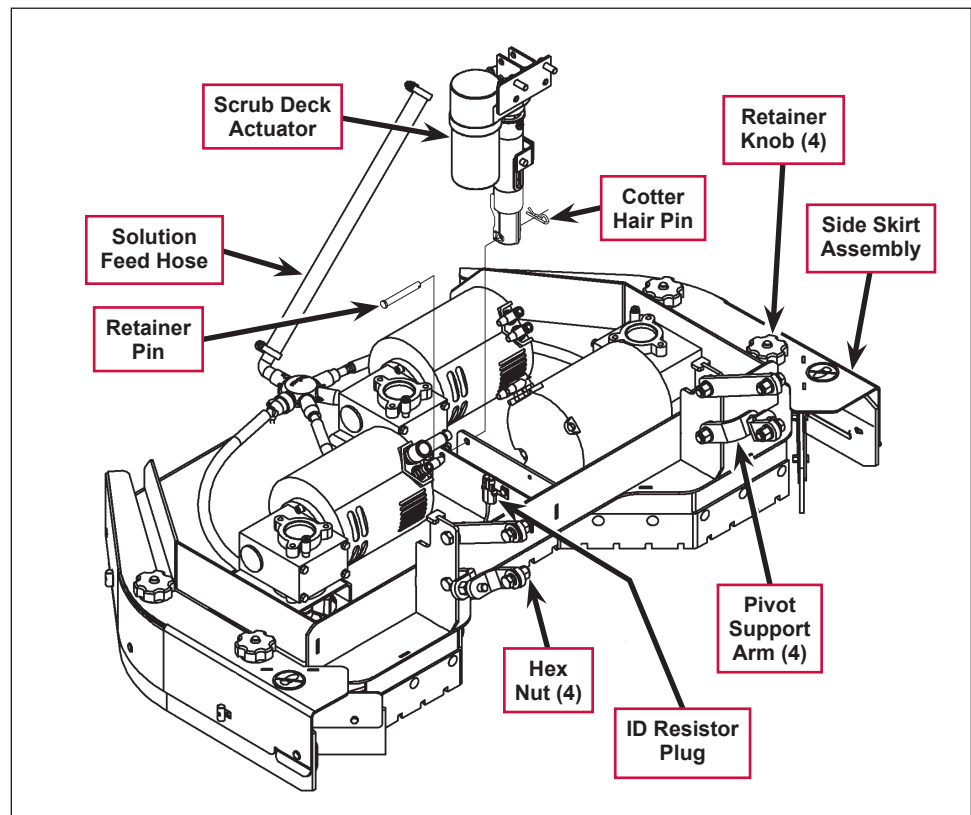

Service Note: Once the brush deck is in the lowered position, don't turn the key switch off until you disconnect the battery pack (push in the Emergency Disconnect). This will prevent the scrub deck from automatically rising when the key is turned off.

4. Turn the key switch off.
5. Remove the **Solution Feed Hose** at solution distribution bladder located on the scrub deck.
6. Remove bottom **Scrub Deck Actuator Cotter Hair Pin**, then push the **Retainer Pin** from its housing and mount bracket holes.
7. Disconnect the **Scrub Deck Actuator** wire harness connector. Note that this will prevent the **Scrub Deck Actuator** from being switched on and rising when it is disconnected from its deck mount.
8. Note the correct brush motor wire connections at each individual motor, then remove all the wiring from the motor terminals.
9. Locate the **ID (identification) Resistor Plug** on the scrub brush deck and separate its connector.

10. Remove the four **Hex Nuts**, hex screws and bushings from the left and right front deck supports, then swing the **Pivot Support Arms** away from their mounting holes.
11. Remove the previously-installed wood blocking from underneath the drive discs. Note that this must be done to get the needed clearance to remove the scrub deck.
12. Carefully slide the complete deck assembly out from underneath the machine from its left side.



Note: Observe the position of the disconnected lift actuator housing and swing it to the rear to clear its mount bracket pocket.

Scrub Deck Lift Actuator



Note: All new replacement actuator motors are not shipped with the lift nut pre-adjusted for any specific machine model application.



Note: The scrub deck must be removed to access the top mount bracket on the scrub deck lift motor.

1. Remove the scrub deck by following the steps in the **Scrub Brush Deck** section.
2. Locate and remove the upper **Cotter Hair Pin** from underneath the middle of the machine.
3. Slide the actuator **Mount Pin** from the housing and frame mounting bracket holes allowing the motor to drop down completing its removal.
4. Refer to the **Drive Nut Adjustment** section for instructions on how to install a new drive nut and set the extended and retracted positions.
5. Follow the above steps in reverse order to install the scrub deck actuator.

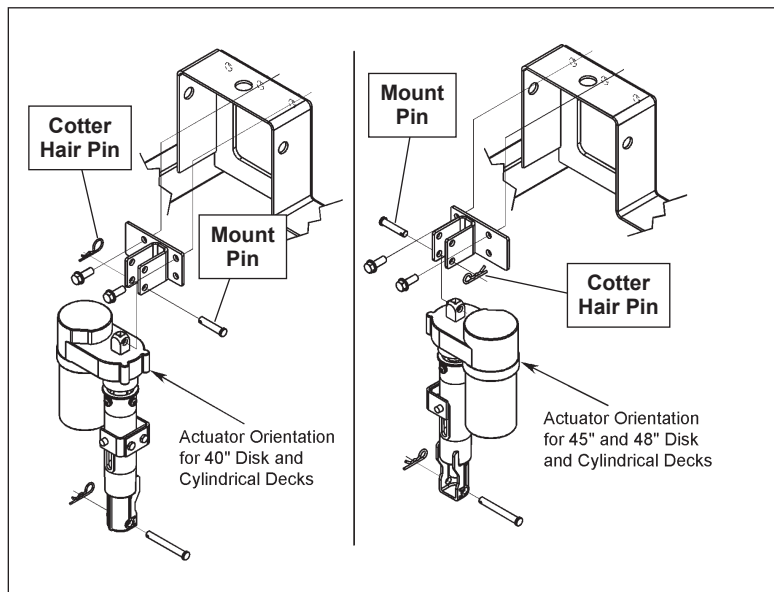

Scrub Brush Motor and Gearbox

To Remove and Install a Gearbox Assembly

1. Remove the scrub brushes from the **Brush Holder(s)**.
2. Use a 13mm socket wrench to remove the three **Screws** from each **Thermoid Disk** (flexible coupler), then remove the **Brush Holder(s)** from the **Drive Hub(s)**.
3. Remove the hex screw and hardened washer holding the **Drive Hub** onto the **Gearbox Assembly**, then pull the **Drive Hub** off of the **Gearbox Output Shaft**. Make sure you save the key stock.
4. Remove the three **Hex Screws** that secure each **Gearbox Assembly** to the deck mounting plate.
5. Separate the **Gearbox Assembly** from the **Deck Weldment** by pulling it straight up.
6. Reassemble the **Gearbox Assembly** to the **Deck Weldment** by following the above steps in reverse order. Make sure to reinstall the key stock.

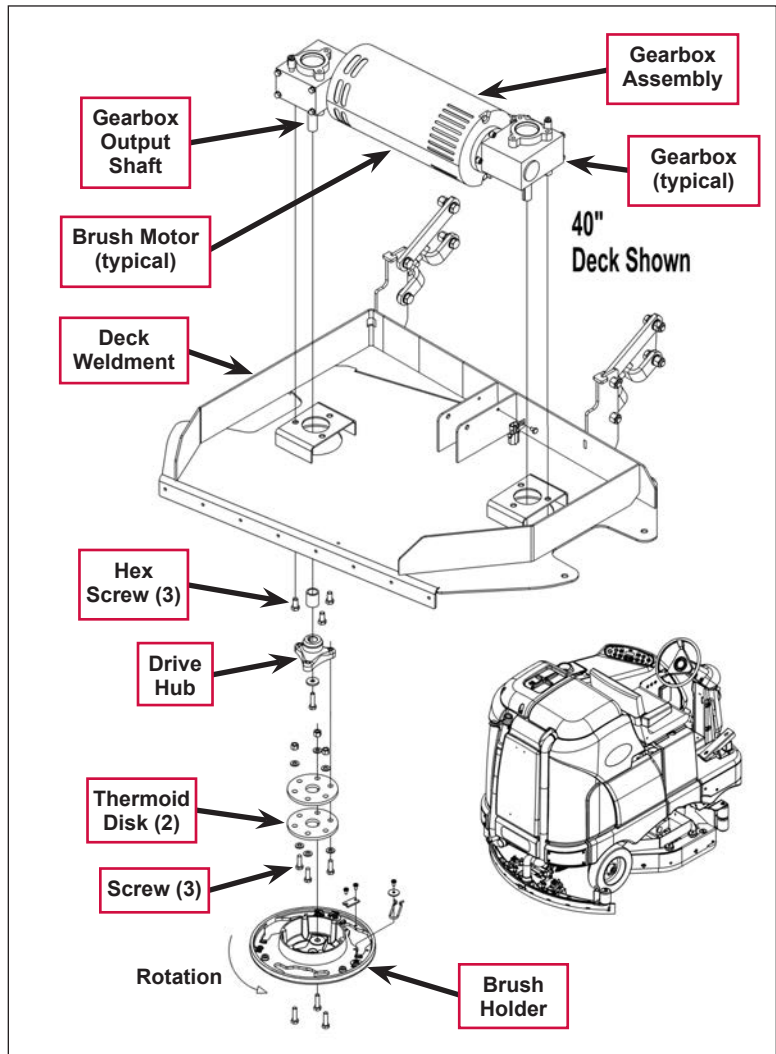

To Disassemble and Reassemble a Gearbox Assembly

1. Remove the three socket head cap screws securing the **Gearbox** to the **Brush Motor**, then separate the **Gearbox** from the **Brush Motor**. Make sure to save the internal **Gearbox** key stock for reassembly.
2. Reassemble the **Gearbox and Brush Motor** by following the above steps in reverse order.



Service Note: Apply a small amount of grease or Never-Seez® anti-seize compound to the **Gearbox** input and output shafts when you reassemble or install a **Gearbox Assembly**. This will aid future disassembly and **Drive Hub** removal.

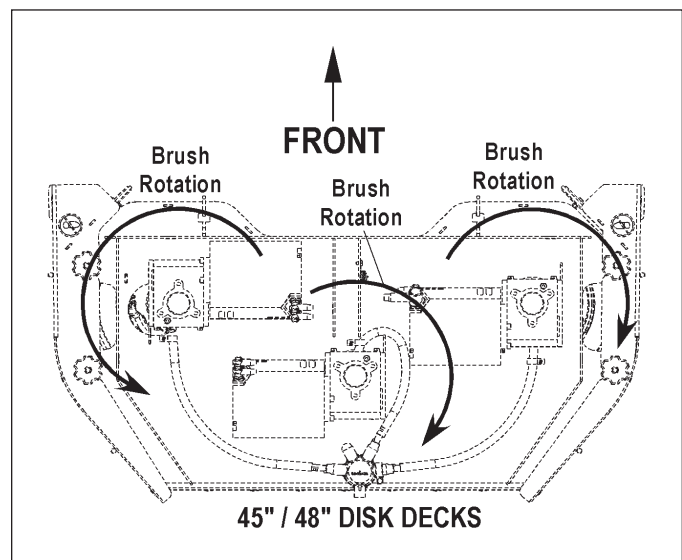

Specifications

Component	Specifications	
Scrub Brush Motors	40" deck	Type – Permanent Magnet
		Voltage – 36 VDC
		Power – 3 HP
		Speed – 2400 RPM
	Current – 75 Amps	
	45" and 48" decks	Voltage – 36 VDC
		Power – 1.5 HP
		Speed – 4000 RPM
Current – 45 Amps		
Deck Actuator Motor	Type – permanent magnet, 36 VDC, 1/5 HP, reversible	
	Motor-to-drive-screw ratio – 19.1:1	
	Performance Data	
	No Load – Thrust 0 lbs., Speed 36 ±4 in/min, 1.0 ±0.5 Amps	
	Full Load – Thrust 600 lbs., Speed 29 ±3 in/min, 5.0 ±1 Amps	
	Stall Current – 25 Amps max.	
	Start Thrust – 600 lbs. min.	

Special Tools

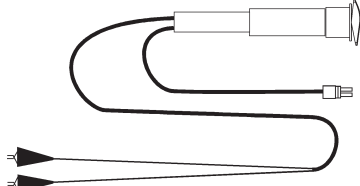
<p>Actuator Power Cord Adapter, p/n 56407502</p>	
--	---

Solution System

Functional Description

Overview

The solution system provides the solution and detergent to the scrub brushes. The solution travels from the **Solution Tank**, through the **Shutoff Valve** and **In-line Solution Filter** to the **Solution Control Pump**. The A2 Control Board provides pulsed-width-modulated (PWM) voltage to the **Solution Control Pump** to regulate the solution flow. The solution flows through the **Solution Solenoid Valve**, through the **Solution Manifold** (disc desks only), then through the various fittings and hoses to the **Scrub Brushes**. Note that the **Solution Solenoid Valve** is full-open whenever the solution system is switched on. The **Drain Hose** allows you to drain the **Solution Tank** by removing the **Drain Plug**.

When the detergent system is switched on, the **Detergent Pumps** pump the detergent from the **Detergent Tank** to a tee fitting upstream of the **Solution Control Pump**. The A2 Control Board provides PWM voltage to the **Detergent Pumps** to regulate the detergent flow.

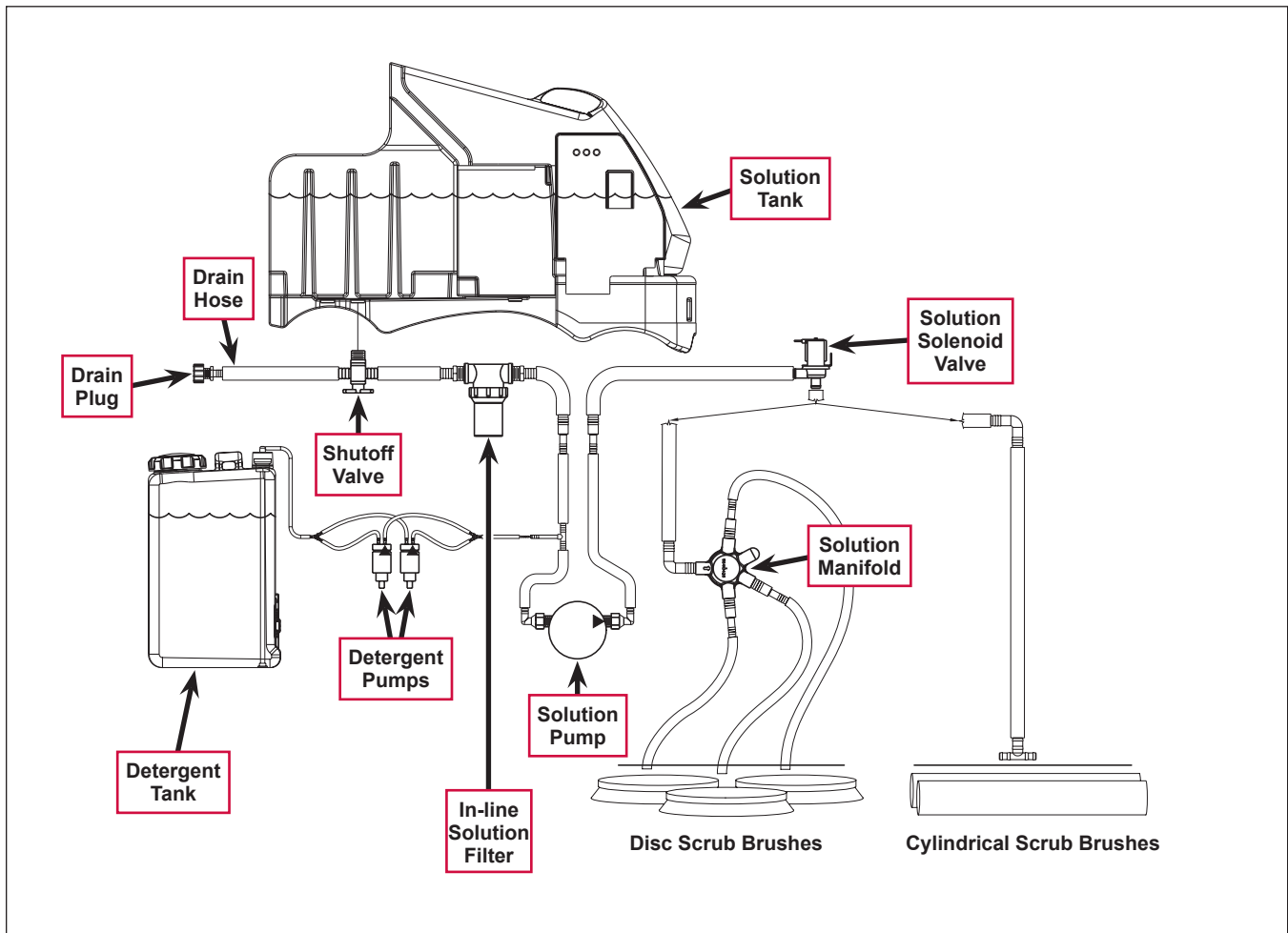

Solution Tank

The **Solution Tank** holds 70 gallons (265 l) of solution. The solution fill cover opens to allow you to fill the **Solution Tank**. The solution empty switch is a float switch that closes and sends a signal to the A2 Control Board Assembly when the solution level in the **Solution Tank** falls to two to three inches from the bottom of the tank. The solution system indicator will flash to remind the operator of the low-solution condition, but the machine will continue to function.

Shutoff Valve

The **Shutoff Valve** allows you to shut off the solution flow from the **Solution Tank** for cleaning and maintenance.

Drain Hose and Hose Cap

The **Drain Hose** allows you to drain the solution tank. To drain the tank, remove the **Drain Hose Cap**.

Solution Filter

The in-line **Solution Filter** prevents any sediment or debris from reaching the solution control pump and solution solenoid valve. The **Solution Filter** can be disassembled for cleaning.

Solution Control Pump

The **Solution Control Pump** pumps the solution through the solution solenoid valve to the nozzles adjacent to the scrub brushes. The **Solution Control Pump** gets PWM voltage from the A2 Control Board to regulate the **Solution Control Pump** speed and the corresponding solution flow.

Solution Solenoid Valve

The **Solution Solenoid Valve** opens to allow solution flow to the scrub brushes. Although the **Solution Solenoid Valve** gets PWM voltage from the A2 Control Board, it remains full-open when the solution pump is switched on.

Solution Manifold (disc decks only)

The **Solution Manifold** distributes the solution from the solution pump to the nozzles adjacent to the scrub brushes.

Accessory Pump

The accessory pump is included in the optional Spray Wand Kit and pumps solution to the spray wand. The pump has its own pressure switch that switches the pump on or off automatically when the wand trigger is pressed or released.

Detergent Tank and Pumps

The **Detergent Pumps** pump detergent from the **Detergent Tank** to the tee fitting upstream of the solution pump. The **Detergent Pumps** get PWM voltage from the A2 Control Board to regulate the speed of the **Detergent Pumps** and the subsequent detergent flow.

Solution System Wiring Diagram

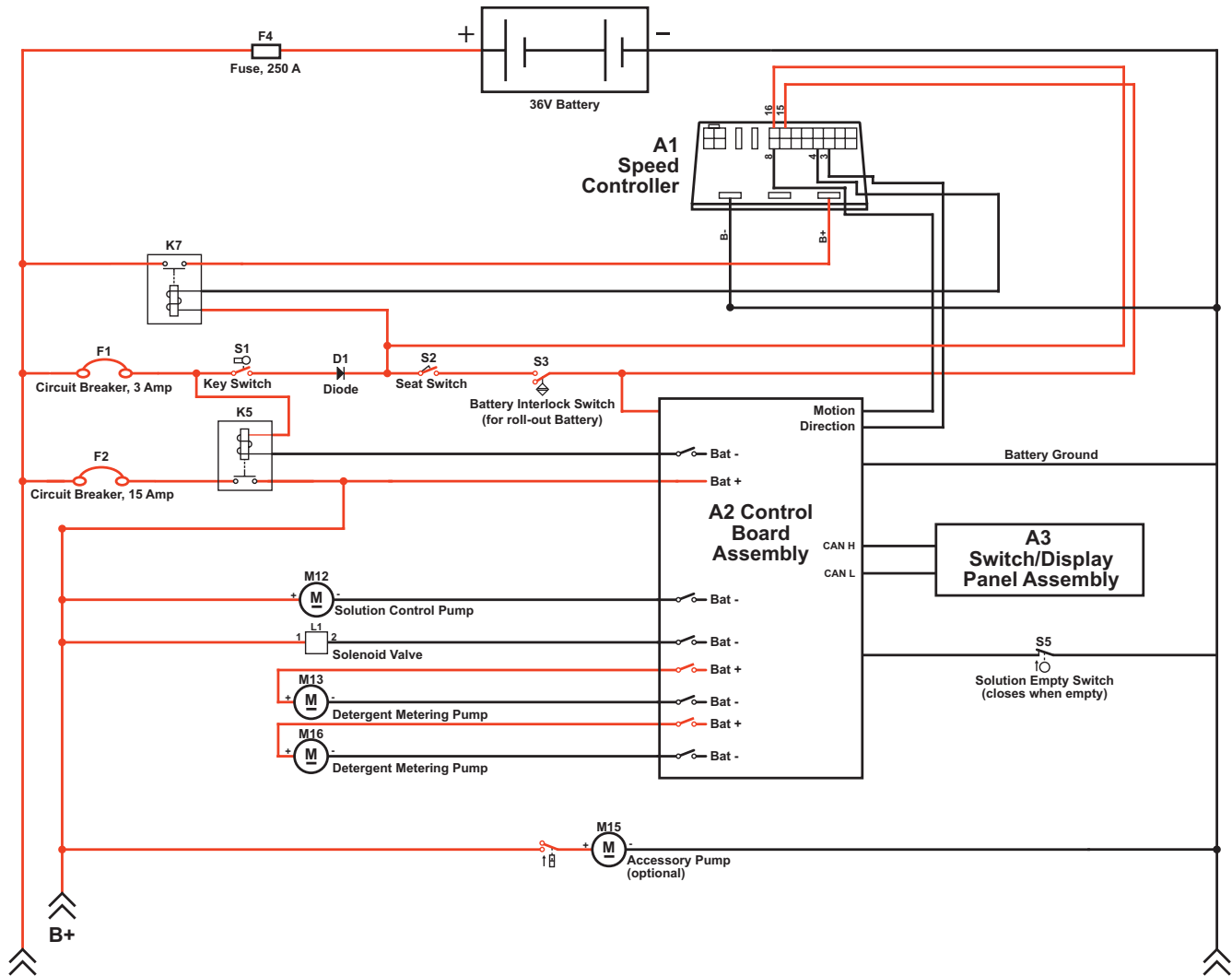

Circuit Description

Solution System

The **Solution Control Pump M12** and solution **Solenoid Valve L1** get positive voltage from the **Battery** when the load side of contactor **K5** is closed. The contactor **K5** closes when the **A2 Control Board Assembly** connects the **K5** coil to battery ground.

The **Solution Control Pump M12** and solution **Solenoid Valve L1** are connected to battery ground through the **A2 Control Board Assembly**. The **A2 Control Board Assembly** connects the **Solution Control Pump M12** and solution **Solenoid Valve L1** to ground to run the **Solution Control Pump M12** and switch on the **Solenoid Valve L1** when:

- The **A3 Switch/Display Panel Assembly** sends the **A2 Control Board Assembly** a signal via the CAN BUS that the solution system has been enabled, and,
- The **A1 Speed Controller** sends the **A2 Control Board Assembly** a signal that the wheel drive is switched on. Note that you can select whether the solution system will switch on when the machine is moving in both forward and reverse, or when moving forward only. This option is described in the **Control System/Main Control Programming Options** section.

Note that the ground voltage from the **A2 Control Board Assembly** to the **Solution Control Pump M12** is pulse-width-modulated (PWM) voltage that varies in frequency to control the solution flow from the **Solution Control Pump M12**. The ground voltage from the **A2 Control Board Assembly** to the **Solenoid Valve L1** is also PWM voltage, but is always at full voltage when the **Solution Control Pump M12** is on.

Detergent System

The **Detergent Metering Pumps M13** and **M16** are powered directly by the **A2 Control Board Assembly**. The **A2 Control Board Assembly** sends the **Detergent Metering Pumps** voltage to run the **Detergent Metering Pumps** when:

- The **A3 Switch/Display Panel Assembly** sends the **A2 Control Board Assembly** a signal via the CAN BUS that the detergent system has been enabled, and,
- The solution system is switched on.

Note that the voltage from the **A2 Control Board Assembly** to the **Detergent Metering Pumps** is PWM voltage that varies in frequency to control the detergent flow from the **Detergent Metering Pumps** into the solution system.

Accessory Pump

The **Accessory Pump M15** gets positive voltage from the **Battery** when the load side of contactor **K5** is closed. When the internal **Accessory Pump** pressure switch is closed, it connects the negative side of the **Pump** motor to battery ground. The pressure switch works as follows:

- When the wand trigger is pressed and the pressure in the wand solution hose drops to a predetermined level, the pressure switch switches on the **Accessory Pump**.
- When the wand trigger is released, the **Accessory Pump** will continue to run momentarily. When the pressure in the wand solution hose increases to a predetermined level, the pressure switch switches off the **Accessory Pump**.

Component Locations

Shutoff Valve

The **Shutoff Valve** is located underneath the solution tank on the left rear side of the machine.

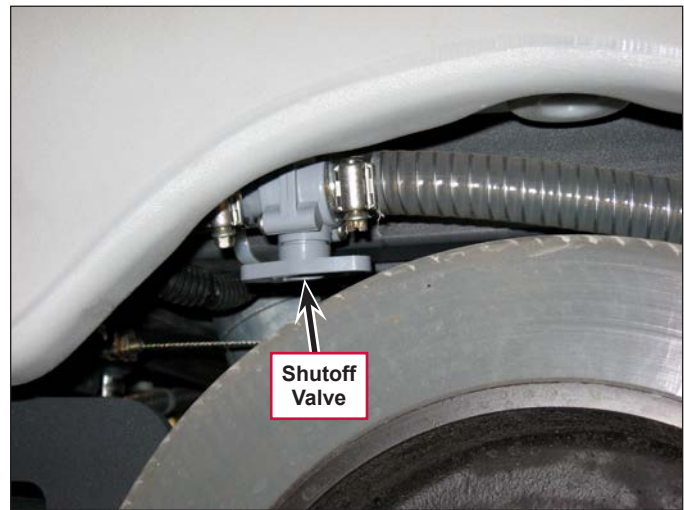

Drain Hose and Hose Cap

The **Drain Hose** and **Drain Hose Cap** are attached to the shutoff valve and are located above the left rear tire.

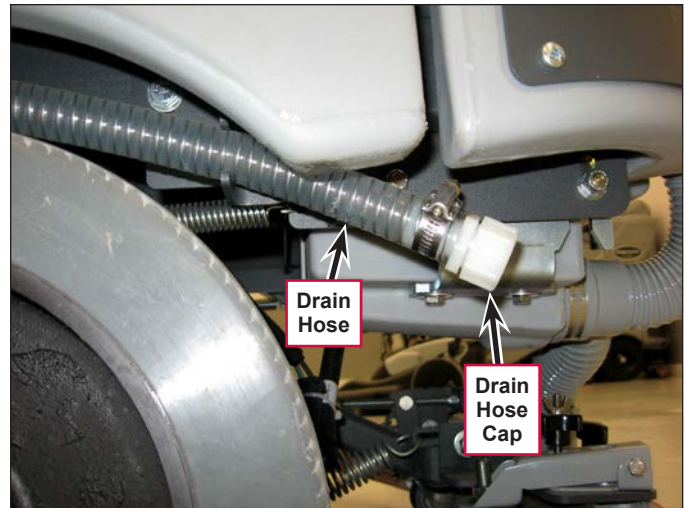

Solution Filter

The in-line **Solution Filter** is located between the shutoff valve and the solution pump underneath the left side of the machine. The **Solution Filter** is below the **FILTER** location arrow  molded into the machine body panel.



Solution Control Pump

The **Solution Control Pump** pumps the solution through the solution solenoid valve to the nozzles adjacent to the scrub brushes. The **Solution Control Pump** gets PWM voltage from the A2 Control Board to regulate the **Solution Control Pump** speed and the subsequent solution flow.



Solution Solenoid Valve

The **Solution Solenoid Valve** opens to allow solution flow to the scrub brushes. Although the **Solution Solenoid Valve** gets PWM voltage from the A2 Control Board, it remains full-open when the solution pump is switched on.



Solution Manifold (disc decks only)

The **Solution Manifold** distributes the solution from the solution pump and solenoid valve to the nozzles adjacent to the scrub brushes.

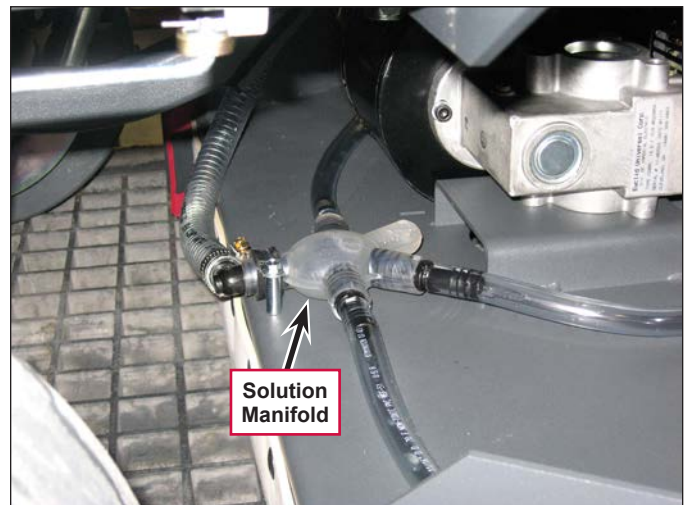

Accessory Pump

The **Accessory Pump** is included in the optional Spray Wand Kit. The pump mounts on the underside of the chassis,

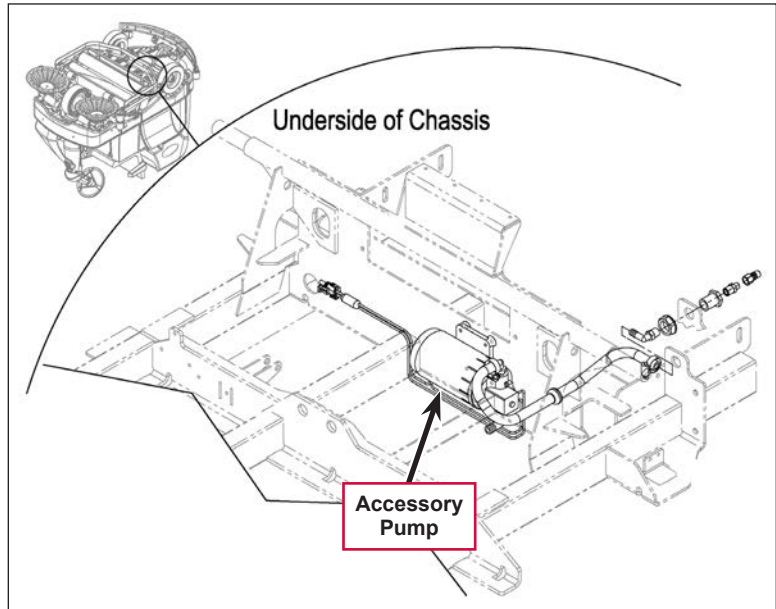

Detergent Tank and Pumps

The **Detergent Tank** and **Detergent Pumps** are located behind the side access panel on the right-hand side of the machine.

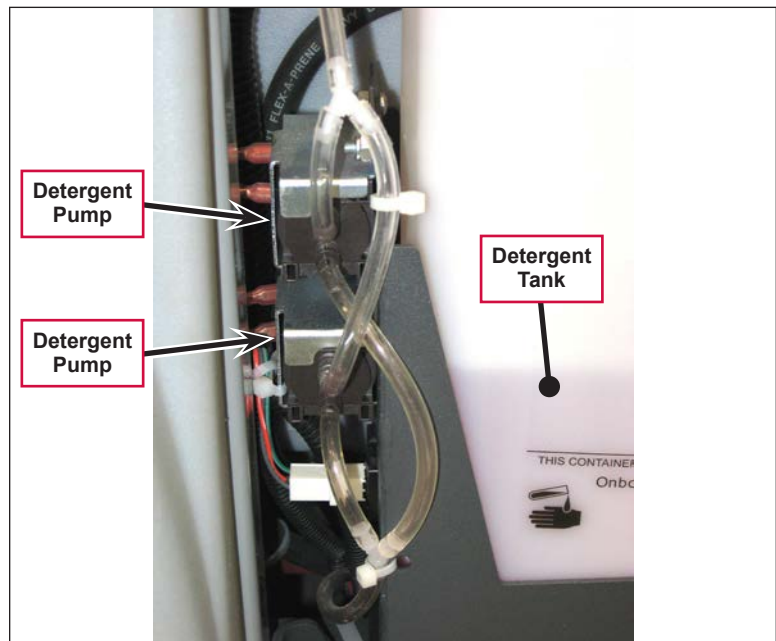

Maintenance and Adjustments



Warning! Before performing any machine maintenance or adjustments, make sure the key switch is off, the key is removed from the machine and the parking brake is engaged.

To Disassemble and Clean the Solution Solenoid Valve

1. Remove the solution solenoid valve from the machine. (Refer to the **Removal and Installation/Solution Solenoid Valve** section.)
2. Remove the four **Screws** and disassemble the solenoid valve. Be careful not to lose any internal parts.
3. Thoroughly wash any dirt or sediment from the **Block** and **Diaphragm**.
4. After you reassemble the solenoid valve, check the valve for correct operation.

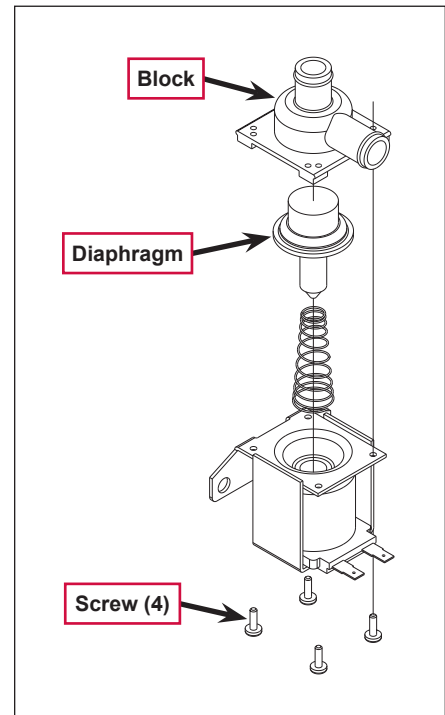

Weekly Maintenance

To Empty and Rinse the Solution Tank

1. Remove the solution drain hose from its storage area (located above the left rear tire).
2. Remove the drain hose cap and direct the hose to a designated disposal site and flush the tank with clean water.
3. Replace the drain hose cap and replace the drain hose in its storage area.

To Clean the Solution Filter

1. Close the solution shutoff valve to prevent solution from draining from the solution tank when servicing the filter with a partial or full solution tank.



Note: Place a suitable container underneath the filter to catch any solution that may leak from the hoses.

The adjacent photo shows the Solution Filter removed from the machine to more clearly show the individual components.

2. Unscrew the **Filter Cover** and remove the **Filter Cover** and **Screen** from the **Filter Base**.
3. Clean any accumulated dirt or debris from the **Screen**.
4. Reinstall the **Screen** into the **Filter Base**.
5. Make sure the **Rubber Washer** is installed correctly in the **Filter Cover**, then reinstall and hand-tighten the **Filter Cover**.

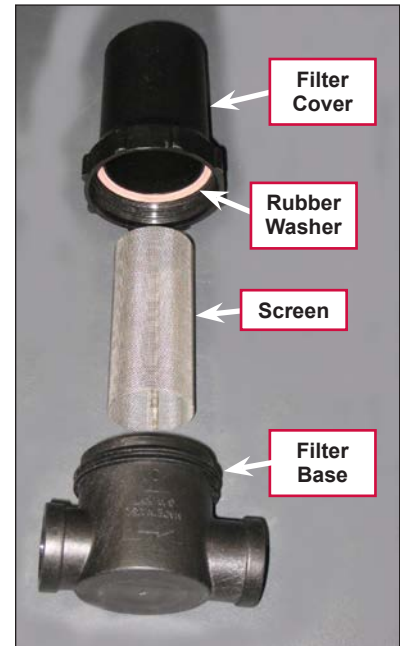

To Clean the Solution Delivery Trough (cylindrical scrub decks only)

Clean the holes in the **Delivery Trough** to ensure even solution distribution.



To Purge the Detergent System

1. Disconnect and remove the detergent tank.
2. Install and connect a tank filled with clean water.
3. Turn the key switch off.
4. Press and hold both the detergent and solution switches.
5. While holding the switches, turn the key switch on. The display will show the purge icon, the detergent and solution pumps will run for 20 seconds, then the pumps will shut off.
6. When the purge cycle is complete, turn the key switch off. Normally one purge cycle is adequate to purge the system.

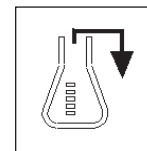

To Purge the Detergent System When Changing Detergents

1. Disconnect and remove the detergent tank.
2. Turn the key switch off.
3. Press and hold both the detergent and solution switches.
4. While holding the switches, turn the key switch on. The display will show the purge icon, the detergent and solution pumps will run for 20 seconds, then shut off.
5. When the purge cycle is complete, turn the key switch off.
6. Install and connect the new detergent tank.

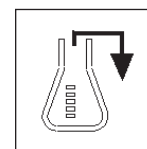

To Program the Detergent Ratio

There are 10 available detergent ratios. Select the desired detergent ratio as follows:

1. Press the detergent switch to turn the detergent system off (if not already off).
2. Press and hold the detergent switch for two seconds to enter the ratio programming mode. The detergent system indicator will blink while in the programming mode.
3. Press the detergent switch to cycle through the available detergent ratios as follows:
 - US Display: 1:32, 1:50, 1:64, 1:100, 1:128, 1:150, 1:200 (shown here), 1:256, 1:300 and 1:400.
 - EU Display: 3%, 2%, 1.5%, 1%, 0.8%, 0.66%, 0.5%, 0.4%, 0.3% and 0.25%.
4. When the desired ratio is displayed, stop pressing the detergent switch. After five seconds the machine will lock in the displayed detergent ratio setting.

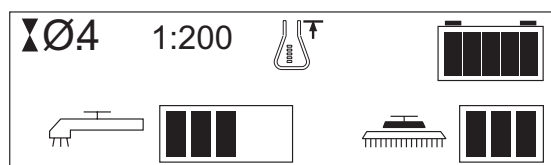

Troubleshooting



Note: You can use the Service Test Mode to toggle the various system components on and off to check for function. Refer to the **Control System/Service Mode** section for information on how to enter and use the Service Test Mode.

Problem	Cause	Correction
Inadequate or no solution flow	The solution shutoff valve is in the off position.	Open the solution shutoff valve.
	Clogged solution filter, solenoid valve, hoses. Clogged solution delivery trough (cylindrical decks only)	<ul style="list-style-type: none"> • Check the solution filter for obstructions and clean as necessary. • Check the solenoid valve for obstructions and clear as necessary. • Check the solution hoses for obstructions and clear as necessary. • Check the solution manifold and solution delivery trough and clear/clean as necessary (disc decks only).
	L1 Solution solenoid open (Main Controller Error Code 33)	<ul style="list-style-type: none"> • Check for open circuit in the L1 coil and wiring (wire colors VIO and YEL/GRN). • Check for 36V at the L1 coil.
	L1 Solution solenoid short to ground (Main Controller Error Code 34)	<ul style="list-style-type: none"> • Disconnect the L1 solenoid coil wiring and check to see if the code disappears. <ul style="list-style-type: none"> – If the code disappears, replace the solenoid. – If the code reappears, test the wiring for a short back to the battery ground. Repair or replace the defective wire. • Substitute a new A1 control board.
	Solution solenoid L1 overload (Main Controller Error Code 12)	<ul style="list-style-type: none"> • Check for a short in the solenoid wiring and repair as necessary. • Check the solenoid coil resistance. The nominal coil resistance is 74 ohms. If the coil resistance is lower than 58 ohms, replace the solution solenoid.
	Solution pump open (Main Controller Error Code 35)	<ul style="list-style-type: none"> • Check for an open circuit in the M12 pump motor and wiring (wire colors VIO and BLU/ORN). • Check for 36V at the pump motor.
	Solution pump overload (Main Controller Error Code 13)	<ul style="list-style-type: none"> • Check for a short in the solution pump wiring and solution pump M12 and repair as necessary. • Disconnect the pump motor and run the machine to see if the wiring is shorted. • Check the pump motor current draw. The normal current load is 0.8 to 1.8 amps. A current load of 3.2 amps or over will cause a pump motor overload error code 13. If the pump motor draws excessive current, replace the pump motor.

Problem	Cause	Correction
Inadequate or no detergent flow	The detergent system has not been selected in the main control programming.	Check that the detergent system has been selected in the main control programming.
	Blockage in or damage to the detergent lines	Check detergent lines for blockage or damage and repair/replace as necessary.
	The detergent tank cap is not sealed on the tank.	Tighten the tank cap. The detergent tank cap must be seated securely and tight to pull (draw detergent) from the tank.
	The detergent pumps are not operating.	<ul style="list-style-type: none"> • Check the wire connections at the detergent pumps for correct wiring polarity. • Make sure the electrical connections are tight and corrosion-free. • With the system activated, touch the pumps to feel them pulsate when operating. If a pump is getting voltage but is not operating, replace the pump.

Removal and Installation



Warning! Before removing or reinstalling any machine components, make sure the key switch is off, the key is removed from the machine and the parking brake is engaged.

Solution Control Pump



Note: Access the solution control pump from underneath the machine.

1. Drain the solution tank or turn the solution shutoff valve to the off position to prevent solution loss.
2. Disconnect the battery from the machine.



Note: Place a suitable container underneath the solution control pump to catch any solution that may leak from the pump or hoses.

3. Disconnect the pump **Electrical Connector** from the machine harness.
4. Remove the four **#10-24 Screws**, Nyloc™ nuts and flat washers holding the **Solution Control Pump** to the bottom of the machine.
5. Loosen the **Clamps** holding the **Hoses** to the **Elbows** and disconnect (pry) the **Hoses** off of the **Elbows**.
6. Remove the **Solution Control Pump** from the machine.
7. Reinstall the **Solution Control Pump** by following the above steps in reverse order.

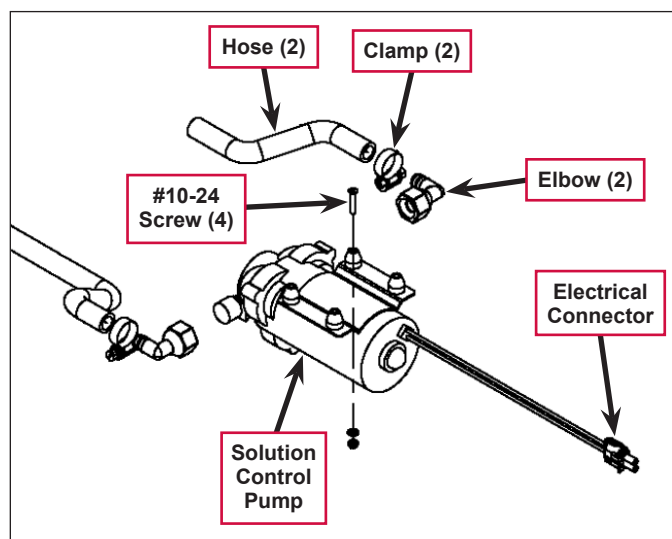

Solution Solenoid Valve

1. Drain the solution tank or turn the solution shutoff valve to the off position to prevent solution loss.
2. Disconnect the battery from the machine.



Note: Place a suitable container underneath the filter to catch any solution that may leak from the solenoid valve or hoses.

3. Disconnect the L1 solenoid valve **Electrical Connector** from the machine harness.
4. Loosen the **Hose Clamps** on the **Inlet** and **Outlet Hoses**.
5. Separate (pry) the **Outlet Hose** off of the barbed fitting on the **Valve Body**.
6. Remove the two **Hex Screws** holding the **Valve Body** to the underside of the chassis, then pull the **Valve Body** toward the front of the machine to separate it from the **Outlet Hose**.
7. Reinstall the solenoid valve by following the above steps in reverse order.

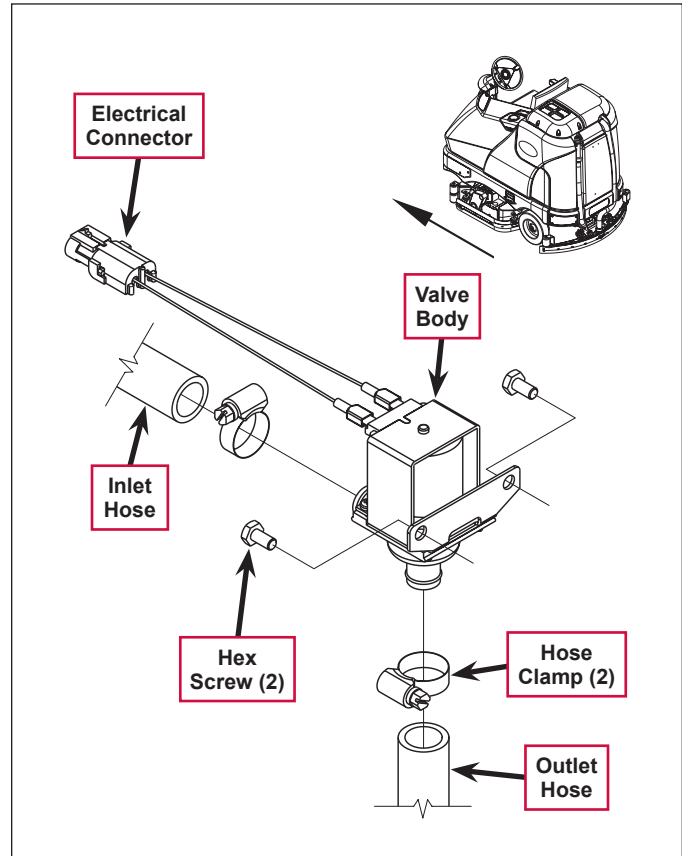

Specifications

Solution Flow Rates

	Standard Flow Rates			Override Flow Rates	
	1 bar	2 bars	3 bars	4 bars	5 bars
40" Disc	.84 GPM	1.00 GPM	1.50 GPM	2.00 GPM	2.50 GPM
40" Cylindrical	.70 GPM	.84 GPM	1.00 GPM	1.50 GPM	2.50 GPM
45"/48" Disc	1.00 GPM	1.50 GPM	2.00 GPM	2.25 GPM	2.50 GPM
45"/48" Cylindrical	.84 GPM	1.00 GPM	1.50 GPM	2.00 GPM	2.50 GPM

Component Specifications

Component	Specifications
Solution Control Pump	Voltage - 36 VDC
	Current Draw - 3.9 amps max.
	Flow Rate - 3.3 GPM @ 2.75 amps with 20 psi inlet pressure
Solution Solenoid Valve	Coil Voltage - 36 VDC
	Coil Resistance - 74 ohms
Accessory Pump	Voltage - 36 VDC
	Current Draw - 3.0 amps max.
	Pressure Control Setting - 100 ±5 psi
	Maximum Flow Rate - 1.6 gal/min
Detergent Pump	Voltage - 24 VDC
	Flow Rate - 87 ±3 ml/min

Squeegee Lift Actuator Reverse Function

The squeegee actuator operates in the automatic mode when scrubbing and will automatically lower to its normal operating position when the scrub system is enabled. To prevent squeegee blade damage and excessive wear, the **Squeegee Actuator M3** will lift the squeegee tool from the floor when the machine is operated in reverse.

To get the squeegee tool to lift in reverse, the drive pedal must be moved off its neutral or forward position, which triggers the needed reverse direction output from the **A1 Speed Controller** to the **A2 Control Board Assembly**. The **A2 Control Board Assembly** sends voltage to the **Squeegee Actuator M3** at the appropriate polarity, and for a specified time, to lift the squeegee to a position that is half the upward distance that the squeegee moves when the scrub system is switched off.

Moving the drive pedal back to the neutral/forward switches off the reverse direction output from the **A1 Speed Controller** to the **A2 Control Board Assembly**. The **A2 Control Board Assembly** then sends voltage to the **Squeegee Actuator M3** at the appropriate polarity to lower the squeegee tool back onto the floor.

Component Locations

The **Squeegee Assembly** is attached to the **Squeegee Mount Weldment**, which is attached to the **Squeegee Lift Arm Weldment**. The **Squeegee Assembly** is fastened to the **Squeegee Mount Weldment** with two **Thumb Nuts**.

The **Squeegee Lift Actuator** raises and lowers the **Squeegee Assembly**, and is mounted horizontally in the left rear of the chassis underneath the recovery tank. The **Squeegee Lift Actuator** is attached to the machine frame and to the **Squeegee Lift Arm Weldment**.

The **Ball Joint** attaches the **Squeegee Lift Arm Weldment** to the frame and allows the **Squeegee Assembly** to move as necessary.

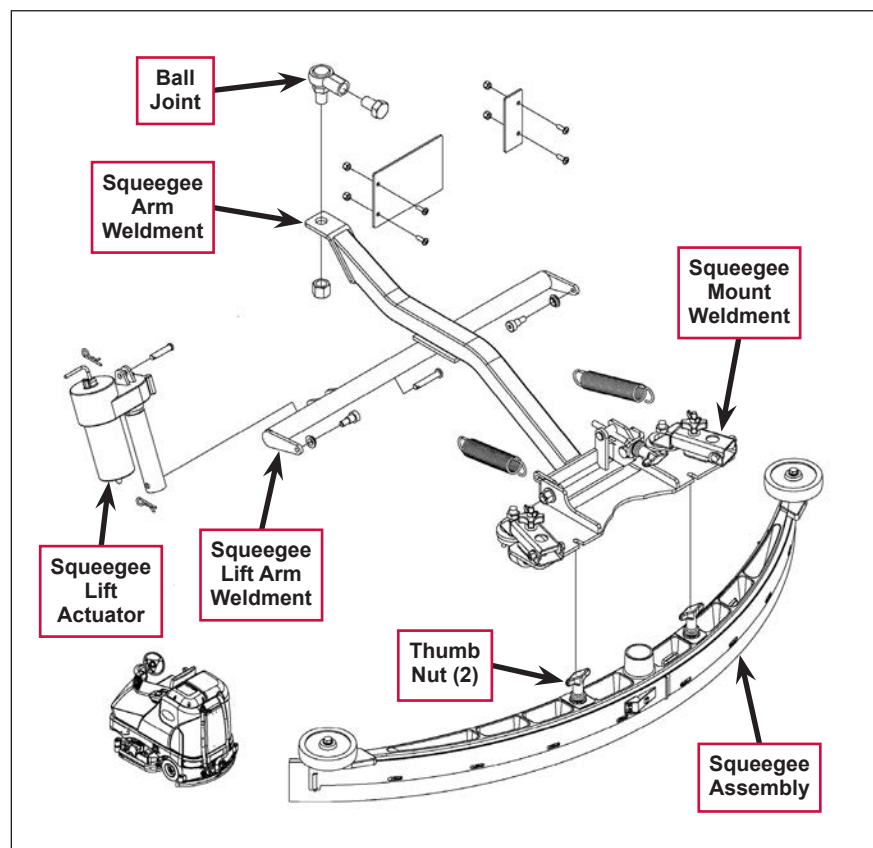

Maintenance and Adjustments



Warning! Before performing any machine maintenance or adjustments, make sure the key switch is off, the key is removed from the machine and the parking brake is engaged.

To Reverse or Replace the Rear Squeegee Wiping Blade

1. Raise the squeegee tool off the floor, then unsnap the **Center Latch** on the squeegee tool.
2. Swing out the **Tension Straps** at both ends, disengage the **Tension Strap** slots from the **Front Strap** and remove the **Tension Straps**.
3. Slip the **Rear Blade** off the alignment pins.
4. The **Rear Blade** has four working edges. Turn the **Rear Blade** so a clean, undamaged edge points toward the front of the machine. Replace the blade if all four edges are nicked, torn or worn to a large radius.
5. Install the **Rear Blade**, following the above steps in reverse order, then adjust the squeegee as necessary.

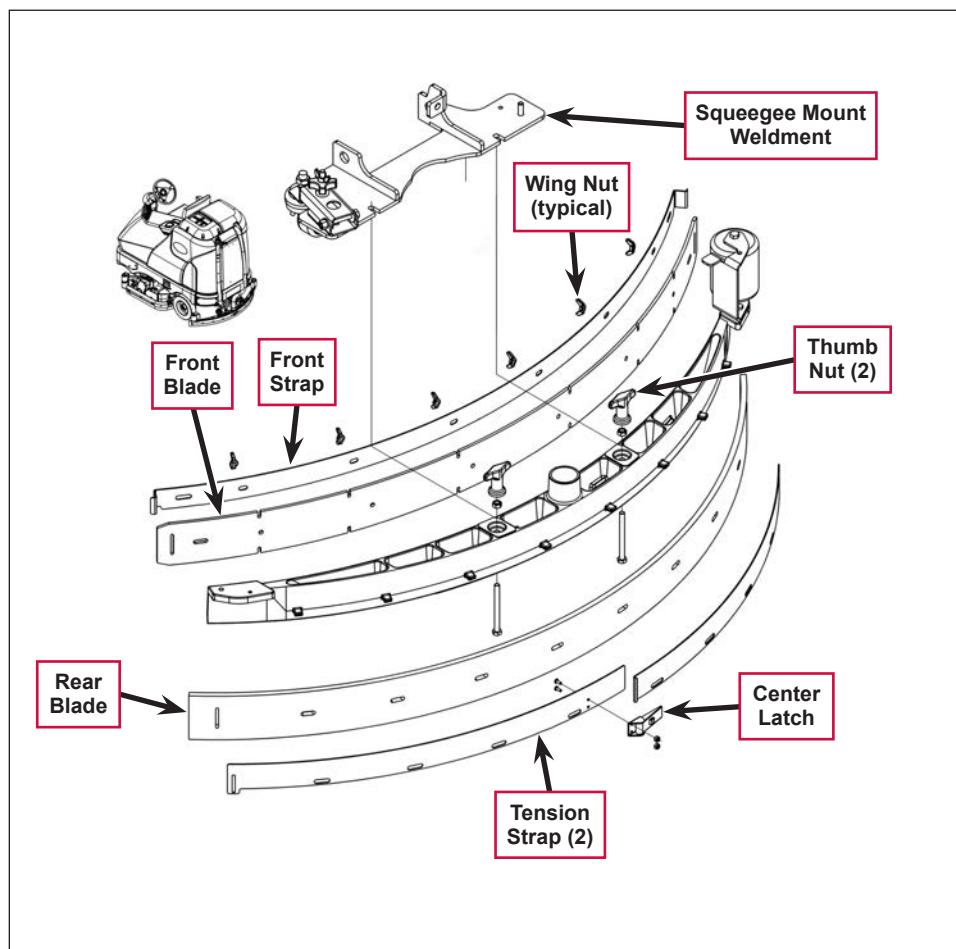

To Reverse or Replace the Front Squeegee Blade

1. Raise the squeegee tool off the floor, then loosen the two **Thumb Nuts** on top of the squeegee and remove the squeegee tool from the **Squeegee Mount Weldment**.
2. Remove both **Tension Straps**, then remove the **Wing Nuts** holding the **Front Blade** in place as shown, then remove the **Front Strap** and **Front Blade**.
3. The **Front Blade** has four working edges. Turn the **Front Blade** so a clean, undamaged edge points toward the front of the machine. Replace the **Front Blade** if all four edges are nicked, torn or worn to a large radius.
4. Install the **Front Blade**, following the above steps in reverse order, then adjust the squeegee as necessary.

Squeegee Adjustment

There are two major squeegee tool adjustments—height and angle. The recommended procedure is to set the squeegee angle first, then adjust the squeegee blade height.

To Adjust the Squeegee Angle

Adjust the squeegee angle whenever a blade is reversed or replaced, or if the squeegee is not wiping the floor dry.

1. Park the machine on a flat, even surface and lower the squeegee.
2. Drive the machine forward enough to have the squeegee blades fold over to the rear as shown in the detail drawing.
3. Turn the **Tilt Adjustment Knob** to tilt the tool forward or backward until the rear squeegee wiping blade touches the floor evenly across its entire width.

To Adjust the Squeegee Blade Height

Adjust the squeegee height whenever a blade is reversed or replaced, or if the squeegee is not wiping the floor dry. The squeegee blade height is easily adjustable at the caster wheels. To adjust the squeegee blade height:

1. Park the machine on a flat, even surface and lower the squeegee.
2. Drive the machine forward enough to have the squeegee blades fold over to the rear as shown in the detail drawing.
3. Rotate the **Caster Adjustment Knobs** clockwise to lift the squeegee, or counterclockwise to lower it. A starting point when replacing the blades is to adjust the caster-mounting bracket so it is level (parallel) to the top of the squeegee tool.

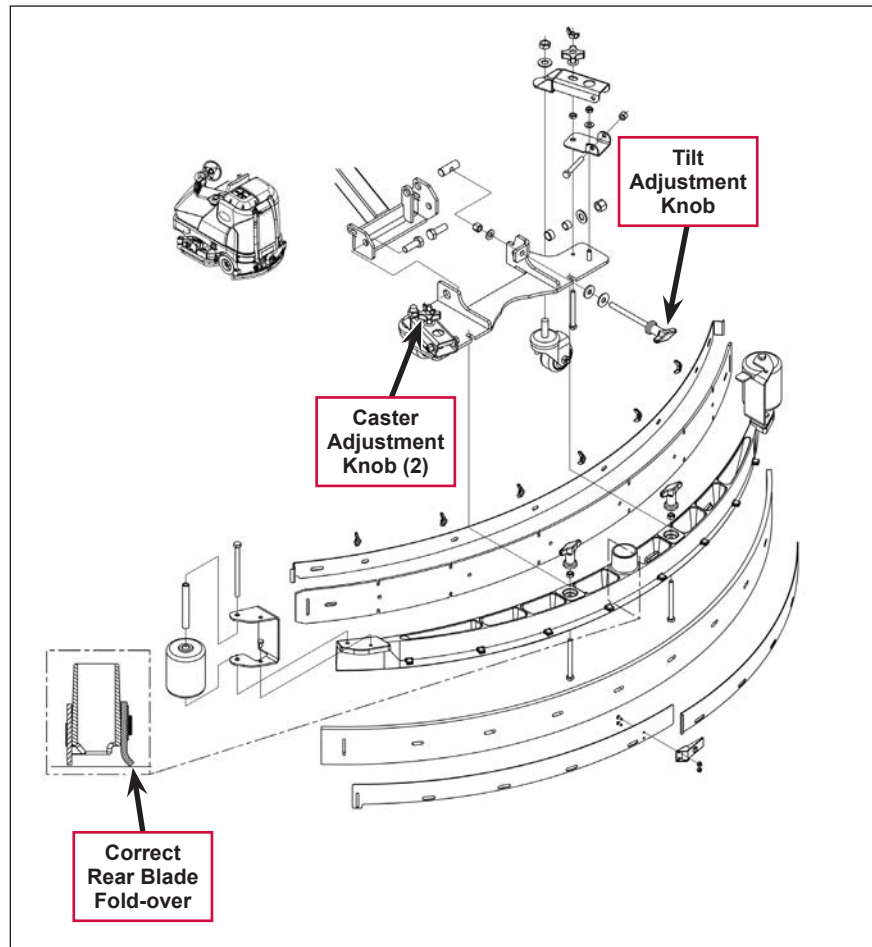

Note: The right and left caster wheels must be adjusted equally to maintain level and even blade pressure.

Lift Actuator Adjustment

Using the Actuator Power Cord Adapter

The adjacent drawing shows the special actuator power cord adapter (p/n 56407502) that is needed to connect the machine's battery pack and actuator motor for setting the actuator drive nut limit settings. To connect the actuator power cord adapter:

1. Open the machine battery compartment and disconnect the battery connector. The battery pack is needed to power the lift actuator motor to correctly set the **IN** and **OUT** limit switches.
2. Connect the actuator motor to be tested to the power cord adapter end.
3. Connect the alligator clips from the cord adapter (red clip to the positive and black to negative) to battery connector or battery posts. Use the rocker switch on the actuator power cord adapter to change the motor rotation when setting the correct actuator drive nut dimensions.

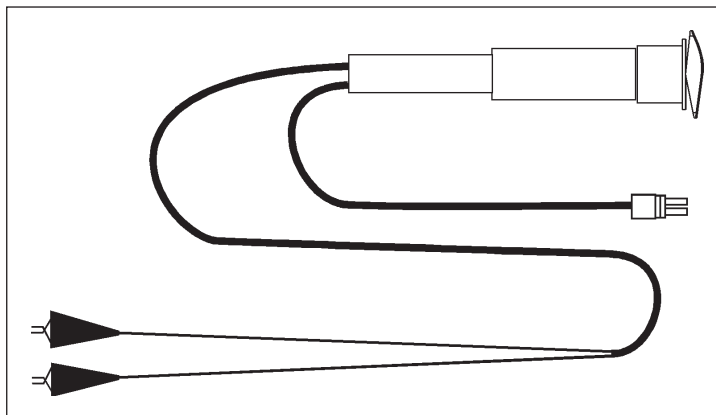

Service Note: You can use the above actuator power cord adapter to help position the drive nut/spring housing assembly (in or out) for ease in actuator motor installations.

Actuator Drive Nut Adjustment

1. Hold onto the **Actuator Drive Nut** and press the rocker switch on the actuator power cord adapter to run the drive motor and retract the **Actuator Drive Nut** toward the motor housing (the **IN** limit).
2. Measure the position of the **Actuator Drive Nut** on the actuator shaft. Manually turn the **Actuator Drive Nut** (steel tube) to the **IN** position as shown in the table on the following page for the specific actuator motor needing adjustment.

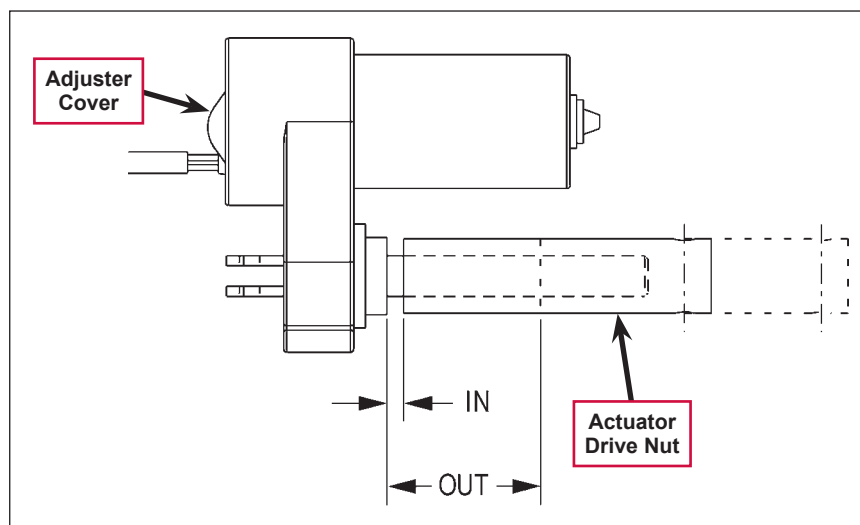

Note: All adjustment settings are measured out of the machine (not attached).

3. Hold the **Actuator Drive Nut** then press the adapter cord rocker switch to run the drive motor to the **OUT** position (wait until the motor stops).

4. Measure the position of the **Actuator Drive Nut** on the shaft and compare the measurement with the **OUT** position shown in the table below.

Part #	Actuator Motor	Actuator Drive Nut IN Position	Actuator Drive Nut OUT Position	Models
56413111	Squeegee Lift	1-1/4" [3.17cm]	3-1/8" [7.93cm]	All

5. If the **OUT** measurement doesn't match the dimension shown in the table, remove the **Adjuster Cover** and adjust the **OUT** position as follows:

- To *increase* the travel of the **Actuator Drive Nut**, turn the adjuster *clockwise*.
- To *decrease* the travel of the **Actuator Drive Nut**, turn the adjuster *counterclockwise*.



Note: Use a 1/2" (13 mm) socket to turn the adjuster. Each click of the adjuster will change the **Actuator Drive Nut** 1/16 inch (1.6 mm).

6. Hold the **Actuator Drive Nut**, run the actuator in and out and check both dimensions after each adjustment.
7. When the **Actuator Drive Nut** limits are set correctly, replace the **Adjuster Cover**.

Troubleshooting

Problem	Cause	Correction
Problem	Cause	Solution
Poor water pick-up	Clogged vacuum hose	Check the vacuum hose and clear/clean as necessary.
	Vacuum leaks	Check the squeegee tool and vacuum hose for leaks or cracks and repair/replace as necessary.
	The squeegee tilt and/or height is set incorrectly,	Adjust the squeegee tilt and/or height as necessary.
The squeegee leaves narrow streaks of water.	The blades are dirty or damaged	Remove the squeegee, rinse it under warm water and inspect the blades. Reverse or replace the blades if they are cut, torn, wavy or worn.
The squeegee lift actuator will not raise or lower the squeegee.	Squeegee actuator overload (error code 11 displayed) <ul style="list-style-type: none"> • Normal current load is 1-2 amps. • Max current load is 6 amps. • Max current with no load is 1.4 amps. 	1. Check for binding or frozen squeegee lift linkage and excessive weight on the squeegee mount. 2. Check for a short circuit in the actuator motor and wiring. Repair or replace. To test the actuator, disconnect the motor plug and attach the actuator power cord adapter (p/n 56407502) and perform an amp draw test. Compare readings to the current load specifications.

Removal and Installation



Warning! Before removing or reinstalling any machine components, make sure the key switch is off, the key is removed from the machine and the parking brake is engaged.

Squeegee Lift Actuator

1. Remove the **Squeegee Tool** from the **Squeegee Mount Weldment**.
2. Lower the squeegee mount to the floor by pressing the Vacuum/Wand Switch on the control panel.
3. Once the brush deck is in the lowered position, disconnect the battery pack (push in the Emergency Disconnect) before you turn the key switch off. This will prevent the squeegee from automatically rising when the key is turned off.
4. Turn the key switch off.
5. Unplug the squeegee lift motor wiring connector from the machine harness.

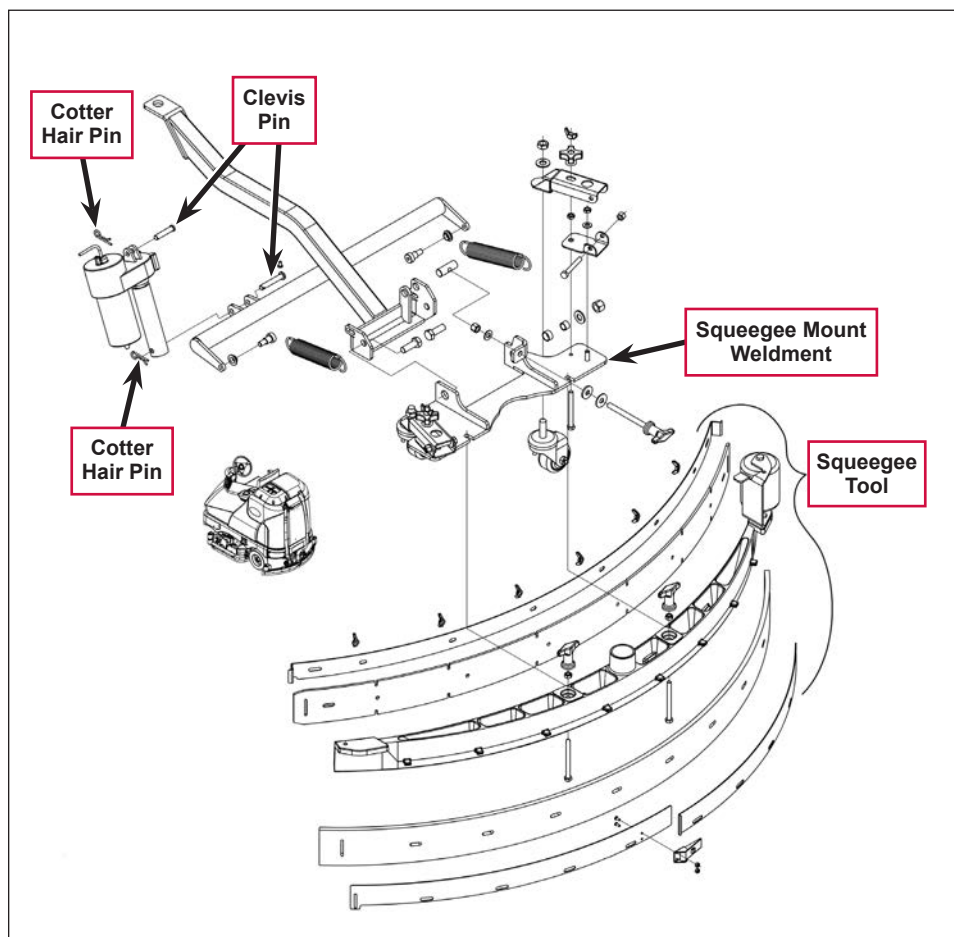

6. Go underneath the machine and remove the two **Hair Cotter Pins**, then slide out (push) both **Clevis Pins** from their mounting holes to remove the lift actuator from the machine.



Note: New replacement lift actuator motors do not come with the lift drive nut pre-adjusted.



Service Note: After removing the lift actuator, and before installing a new actuator or drive nut, the drive nut and limit switches must be set (or checked) to their correct specifications. Refer to the **Lift Actuator Adjustment** section.

7. After checking or setting the correct actuator lift drive nut dimensions, install the squeegee lift actuator by following the above steps in reverse order.



Service Note: Connect the special actuator power cord adapter to the lift motor as shown in the **Lift Actuator Adjustment** section to help position the lift actuator for an easier installation.

Specifications

Component	Specifications
Squeegee Actuator Motor	Type – permanent magnet, 36 VDC, 1/6 HP, reversible
	Motor-to-drive-screw ratio – 27.1:1
	Performance Data
	No Load – Thrust 0 lbs., Speed 39 in/min, 1.4 Amps max.
	Full Load – Thrust 600 lbs., Speed 30 in/min, 6.7 ±1 Amps
	Start Thrust – 600 lbs.

Special Tools

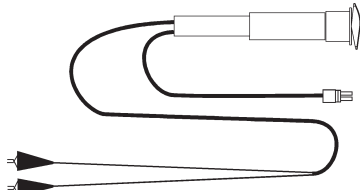
<p>Actuator Power Cord Adapter, p/n 56407502</p>	
--	--

Sweep System, Side Broom

Functional Description

Overview

The optional side brooms are available on cylindrical deck machines only. The two 20-inch [50.8 cm] side brooms are mounted at the front corners of the machine and rotate in opposite directions to sweep dirt and debris into the main cylindrical brushes. The main cylindrical brushes then sweep the dirt and debris into a removable hopper.

The side broom lift actuator raises and lowers the side brooms via a pivoting arm linkage assembly. The side brooms will be lowered automatically when the scrub system is enabled. Note that this automatic side broom function can be enabled or disabled in the main control programming options. The broom motors will switch on when the drive pedal is moved from the neutral position.

Side Broom Sweep System Wiring Diagram

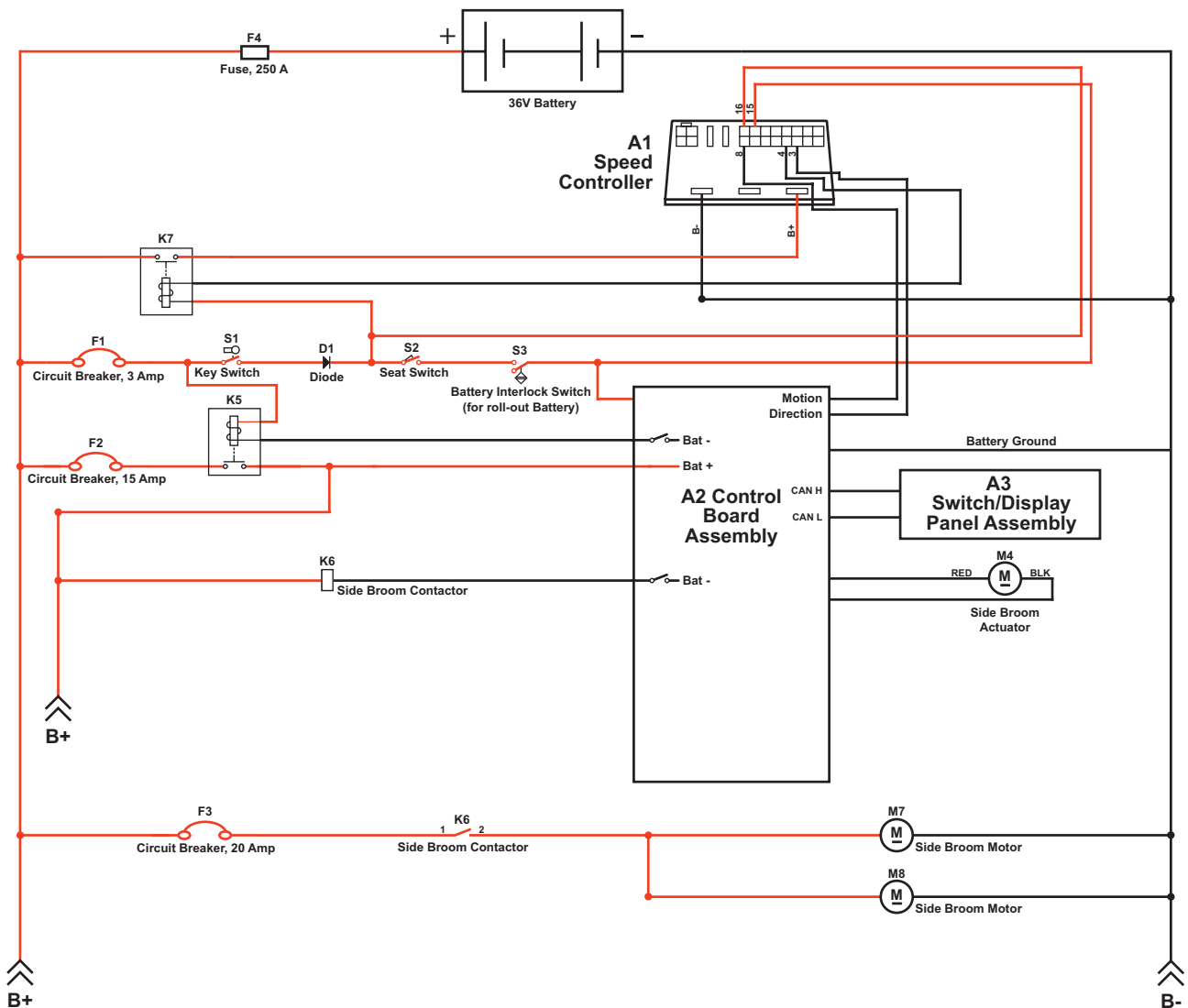

Circuit Description

The coil side of contactor **K6** gets positive voltage from the **Battery** when the load side of contactor **K5** is closed. Contactor **K5** closes when the **A2 Control Board Assembly** connects the **K5** coil to battery ground. Contactor **K6** is connected to battery ground through the **A2 Control Board Assembly**.

The **Side Broom Motors M7** and **M8** get positive voltage from the **Battery** when the load side of contactor **K6** is closed. Contactor **K6** closes when the **A2 Control Board Assembly** connects the **K6** coil to battery ground. The **Side Broom Motors M7** and **M8** are connected directly to battery ground.

The **Side Broom Actuator M4** gets voltage from the **A2 Control Board Assembly** which switches the polarity to move the side brooms up or down. When the **A2 Control Board Assembly** receives a signal from the **A3 Switch/Display Panel Assembly** via the CAN BUS that the operator has pressed the scrub on switch, the **A2 Control Board Assembly** sends the appropriate voltage to the **Side Broom Actuator M4** to lower the side brooms to the operating position.

Component Locations

The **Side Broom Assemblies** are mounted onto the **Side Broom Bracket Weldments** using parallel **Links**, sleeve bearings, bushings and fasteners.

The **Side Broom Lift Actuator** is mounted horizontally is attached to the machine frame and **Lift Arm** with clevis pins. The **Lift Arm** is connected via short chains to the **Side Broom Assemblies**. As the **Side Broom Lift Actuator** retracts and extends, it pivots the **Lift Arm** to raise and lower the **Side Broom Assemblies**.

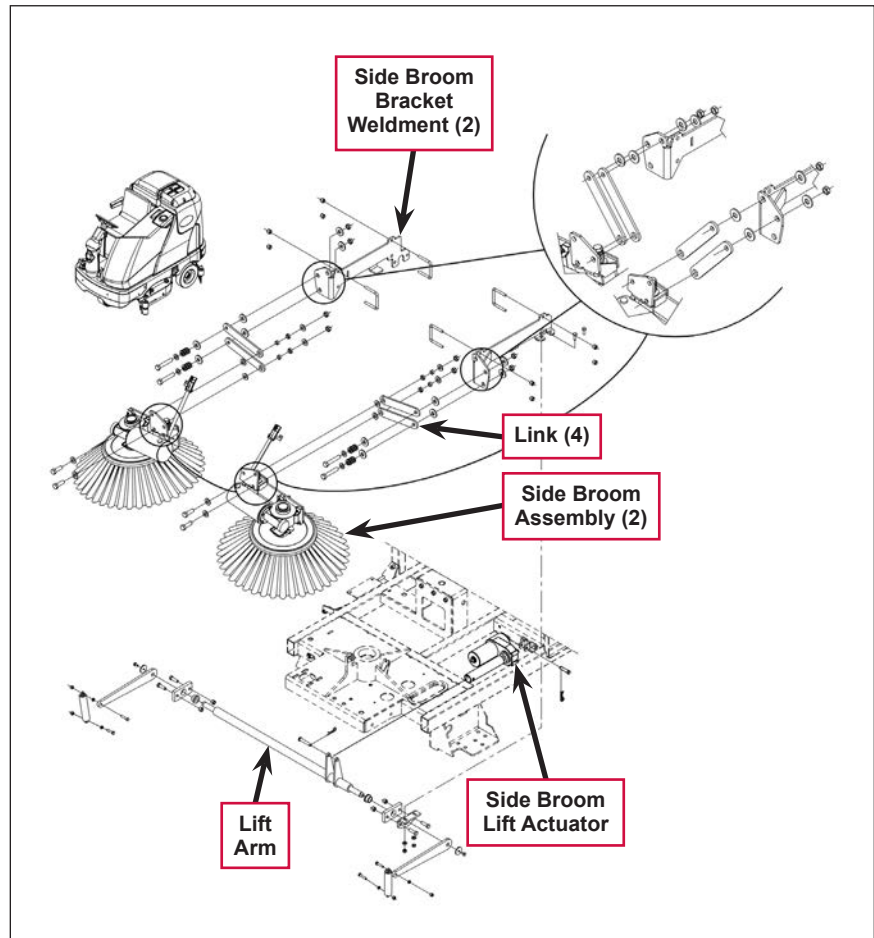

Maintenance and Adjustments



Warning! Before performing any machine maintenance or adjustments, make sure the key switch is off, the key is removed from the machine and the parking brake is engaged.

Side Broom Height Adjustment

The height of the side brooms is determined by the length of time the side broom actuator runs as it lowers the side brooms. Note that:

- Increasing the side broom actuator run time lowers the side broom height.
- Decreasing the side broom actuator run time raises the side broom height.

To adjust the side broom height:

1. Turn the key switch off.
2. Press and hold the side broom on/down and scrub off switches.
3. While holding the switches, turn the key switch on.
4. Continue to hold the switches until the side broom on/down indicator, scrub off indicator and both scrub on indicators turn on.
5. Release the switches. The indicators will stay on and the display will now show the side broom actuator down run time in seconds.
6.
 - Press the scrub on switch to increase the side broom actuator run time and lower the position of side brooms.
 - Press the side broom on/down switch to decrease the side broom actuator run time and raise the position of side brooms.
7. Press the scrub off switch to save the side broom height. The actuator will rise to its up position and the display will show a key switch icon.
8. Turn the key switch off. The machine is now reprogrammed to work with the new side broom height setting.

Lift Actuator Adjustment

This section explains the steps for adjusting the actuator drive nut (**Spring Housing Assembly**) setting for the lift actuator motor.

Using the Actuator Power Cord Adapter

The adjacent drawing shows the special actuator power cord adapter (p/n 56407502) that is needed to connect the machine's battery pack and actuator motor for setting the actuator drive nut limit settings. To connect the actuator power cord adapter:

1. Open the machine battery compartment and disconnect the battery connector. The battery pack is needed to power the lift actuator motor to correctly set the **IN** and **OUT** limit switches.
2. Connect the actuator motor to be tested to the power cord adapter end.
3. Connect the alligator clips from the cord adapter (red clip to the positive and black to negative) to battery connector or battery posts. Use the rocker switch on the actuator power cord adapter to change the motor rotation when setting the correct actuator drive nut dimensions.

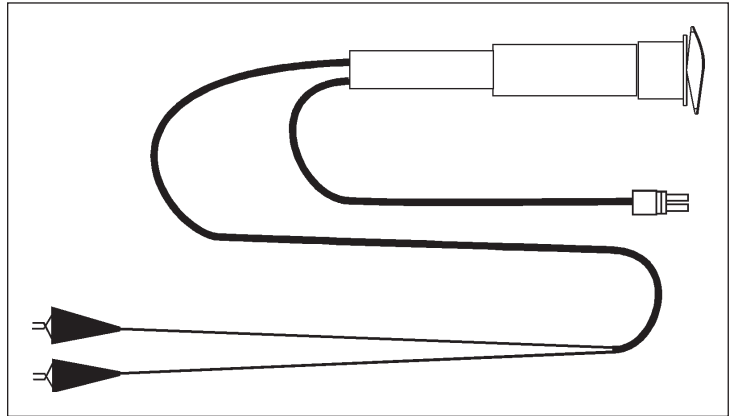

Service Note: You can use the above actuator power cord adapter to help position the drive nut/spring housing assembly (in or out) for ease in actuator motor installations.

Lift Actuator Drive Nut Adjustment

1. Hold onto the **Actuator Drive Nut** and press the rocker switch on the actuator power cord adapter to run the drive motor and retract the **Actuator Drive Nut** toward the motor housing (the **IN** limit) until the motor stops.
2. Measure the position of the **Actuator Drive Nut** on the actuator shaft. Manually turn the **Actuator Drive Nut** (steel tube) to the **IN** position as shown in the table on the following page for the specific actuator motor needing adjustment.

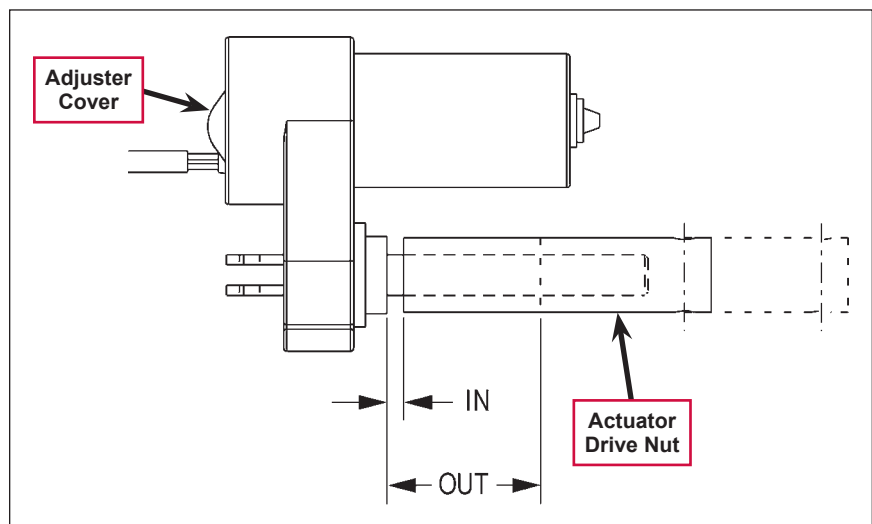

Note: All adjustment settings are measured out of the machine (not attached).

3. Hold the **Actuator Drive Nut** then press the adapter cord rocker switch to run the drive motor to the **OUT** position (wait until the motor stops).
4. Measure the position of the **Actuator Drive Nut** on the shaft and compare the measurement with the **OUT** position shown in the table below.

Part #	Actuator Motor	Actuator Drive Nut IN Position	Actuator Drive Nut OUT Position	Models
56413129	Side Broom Lift	1-5/8" [4.12cm]	3-1/8" [7.93cm]	Cylindrical w/side brooms

5. If the **OUT** measurement doesn't match the dimension shown in the table, remove the **Adjuster Cover** and adjust the **OUT** position as follows:
 - To *increase* the travel of the **Actuator Drive Nut**, turn the adjuster *clockwise*.
 - To *decrease* the travel of the **Actuator Drive Nut**, turn the adjuster *counterclockwise*.



Note: Use a 1/2" (13 mm) socket to turn the adjuster. Each click of the adjuster will change the **Actuator Drive Nut** 1/16 inch (1.6 mm).

6. Hold the **Actuator Drive Nut**, run the actuator in and out and check both dimensions after each adjustment.
7. When the **Actuator Drive Nut** limits are set correctly, replace the **Adjuster Cover**.

Troubleshooting

Problem	Cause	Correction
Poor sweeping performance	Brushes are worn or damaged	Check and replace the brushes as necessary.
	The broom height is not set correctly.	Check and reset the broom height. Refer to the Side Broom Height Adjustment section.
	The brush gearmotor is not operating correctly.	Check the gearmotor current draw with no load (6 amps nominal). Replace the gearmotor if necessary.
A side broom motors will not run.	K6 Side broom motor contactor coil overload (error code 16 displayed) The nominal coil resistance is 100 ohms.	<ol style="list-style-type: none"> 1. Check for a K6 coil wiring problem or short circuit (wire colors VIO and BRN/BLK). 2. Check the coil resistance. If the resistance is below 80 ohms, replace the contactor.
	Side broom motor contactor coil open (error code 36 displayed)	<ol style="list-style-type: none"> 1. Check for open circuit in the K6 coil and wiring (wire colors VIO and BRN/BLK). 2. Test for 36V at the K6 coil. If 0 Volts, check the A2 control board assembly.
	K6 Side broom motor contactor coil short to ground (error code 37 displayed)	<ol style="list-style-type: none"> 1. Disconnect the K6 coil wiring (wire colors VIO and BRN/BLK) and check to see if the code disappears. <ul style="list-style-type: none"> – If the code disappears, replace the K6 contactor. – If the code does reappear, test the wiring for a short back to the battery ground. Repair or replace the defective wire. 2. If the above test doesn't remove the code, substitute a new A2 control board assembly.
The side brooms will not extend or retract.	Side broom actuator overload (error code 17 displayed) <ul style="list-style-type: none"> • Normal current load is 1-2 amps. • Max current load is 6 amps. • Max current with no load is 1.4 amps. 	<ol style="list-style-type: none"> 1. Check for binding or frozen side broom lift linkage and excessive weight on the lifting arms. 2. Check for a short circuit in the actuator motor and wiring. Repair or replace. To test the actuator, disconnect the motor plug and attach the actuator power cord adapter (p/n 56407502) and perform an amp draw test. Compare readings to the current load specifications.
	Side broom actuator motor open (error code 38 displayed)	<ol style="list-style-type: none"> 1. Use an ohmmeter to check for an open circuit in the M4 side broom actuator and its wiring (wire colors GRA/VIO and GRN/ORN). If defective, repair or replace. 2. Test for 36V at side broom actuator. If 0 Volts, check the A2 control board assembly.

Removal and Installation



Warning! Before removing or reinstalling any machine components, make sure the key switch is off, the key is removed from the machine and the parking brake is engaged.

Side Broom Lift Actuator



Note: New replacement lift actuator motors do not come with the lift drive nut pre-adjusted.

1. Remove the scrub deck. (Refer to the **Removal and Installation/Scrub Brush Deck** instructions in the **Scrub System, Cylindrical** section of this manual.)
2. The side broom lift actuator motor is located underneath the left front of the machine ahead of its side skirt. Cut the wiring tie strap if needed, then disconnect the wiring connector at the motor.

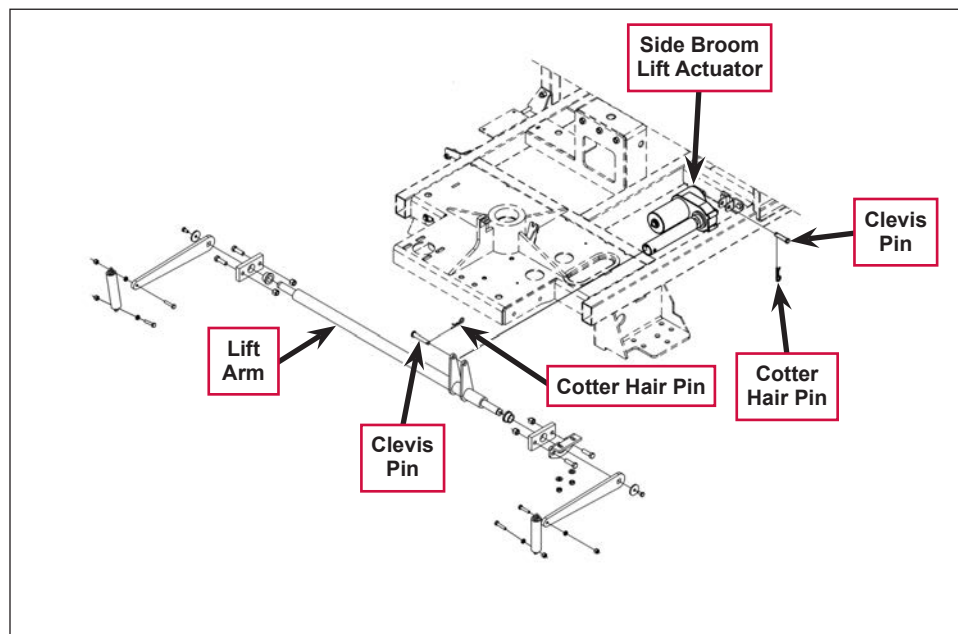

3. Pull out the two **Cotter Hair Pins**, then remove the two **Clevis Pins** holding the motor at the frame and **Lift Arm** mounts.



Service Note: It may be helpful to lift up and down on the **Lift Arm** to relieve any preload pressure on the **Clevis Pins** when removing the front **Clevis Pin**.

4. Drop the **Side Broom Lift Actuator** out from underneath the machine to remove it.



Note: New replacement lift actuator motors do not come with the lift drive nut pre-adjusted.



Service Note: After removing the lift actuator, and before installing a new actuator or drive nut, the drive nut and limit switches must be set (or checked) to their correct specifications. Refer to the **Lift Actuator Adjustment** section.

5. After checking or setting the correct actuator lift drive nut dimensions, install the side broom lift actuator by following the above steps in reverse order.



Service Note: Connect the special actuator power cord adapter to the lift motor as shown in the **Lift Actuator Adjustment** section to help position the lift actuator for an easier installation of the **Clevis Pins**.

Side Broom Gearmotor

1. Remove the **Side Broom Retainer Pin**, then pull down on the **Side Broom** and remove it from the motor shaft.
2. Disconnect the motor wiring connector from the main machine harness. Note that you may need to cut the tie straps to do this.
3. Remove the fasteners holding the **Gearmotor Assembly** to the **Side Broom Bracket Weldment**.
4. Install the **Side Broom Motor** by following the above steps in reverse order.
5. Note that the position of the mounting screws inside the three **Die Springs** set the spring tension for the side broom front and side impact breakaway.

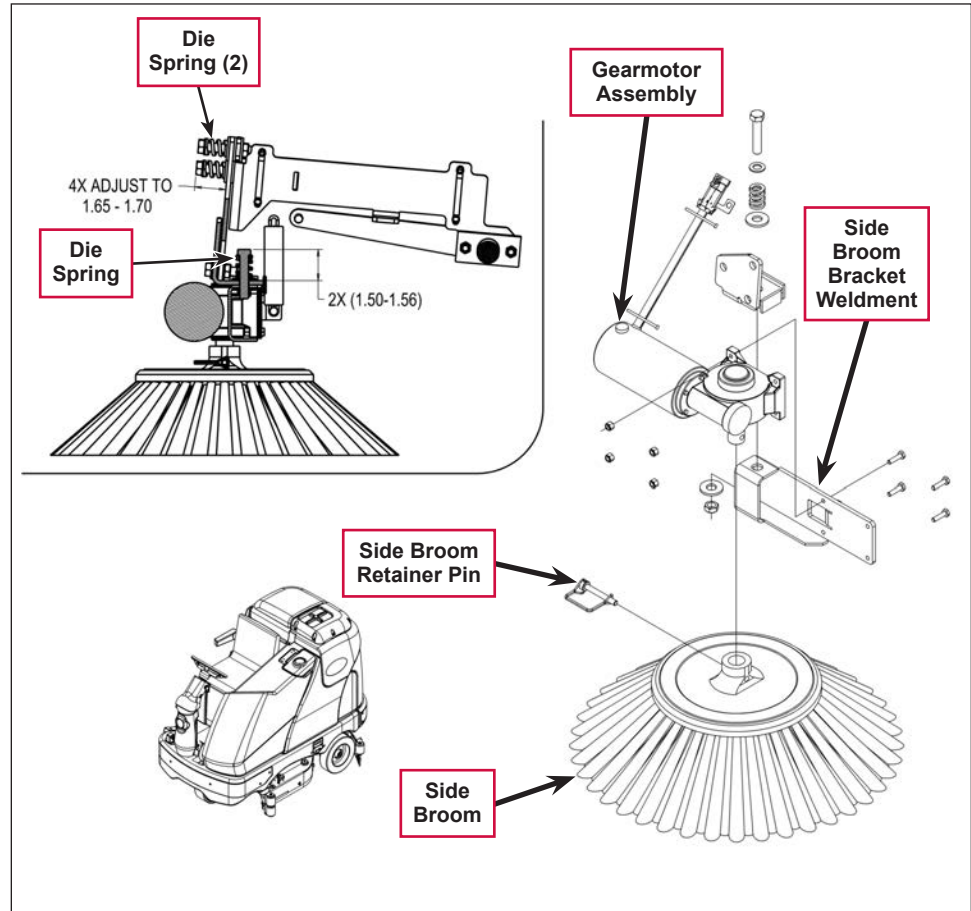

Once you've reinstalled the **Gearmotor Assembly**, adjust the mounting screws inside the **Die Springs** to the dimensions shown in the detail drawing above.

6. Test the side broom **Gearmotor Assembly** for correct operation.

Specifications

Component	Specifications
Side Broom Gearmotor	Type – permanent magnet, 36 VDC
	Gearbox – 27:1 ratio
	Power – 162 Watts
	Output – 105 in-lbs. @ 84 RPM
	Current – 6 Amps
Side Broom Actuator Motor	Type – permanent magnet, 36 VDC, 1/6 HP, reversible
	Motor-to-drive-screw ratio – 21.7:1
	Performance Data
	No Load – Thrust 0 lbs., Speed 39 ±4 in/min, 1.4 Amps max.
	Full Load – Thrust 600 lbs., Speed 30 ±3 in/min, 6.7 ±1 Amps
	Start Thrust – 600 lbs.

Special Tools

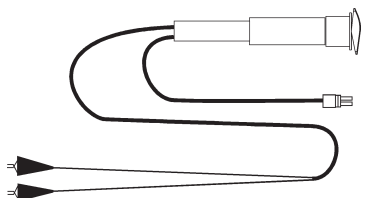
<p>Actuator Power Cord Adapter, p/n 56407502</p>	
--	---

Wheel System, Non-traction

Functional Description

Overview

The non-traction wheel system supports the rear of the machine and includes the braking system.

Component Locations

The **Non-traction (rear) Wheels** are attached to the brake **Spindles** and are held on the frame shafts by a M10-1.5 x 20mm hex screw and washer.

The **Brake Pedal Assembly** actuates the **Brakes** via a **Cable Assembly**. The **Brake Pedal Assembly** can be locked with the **Brakes** engaged to act as a parking brake.

The **Cable Assembly** actuates an **Equalizer** that ensures the tension from the **Cable Assembly** is applied equally to both brakes.

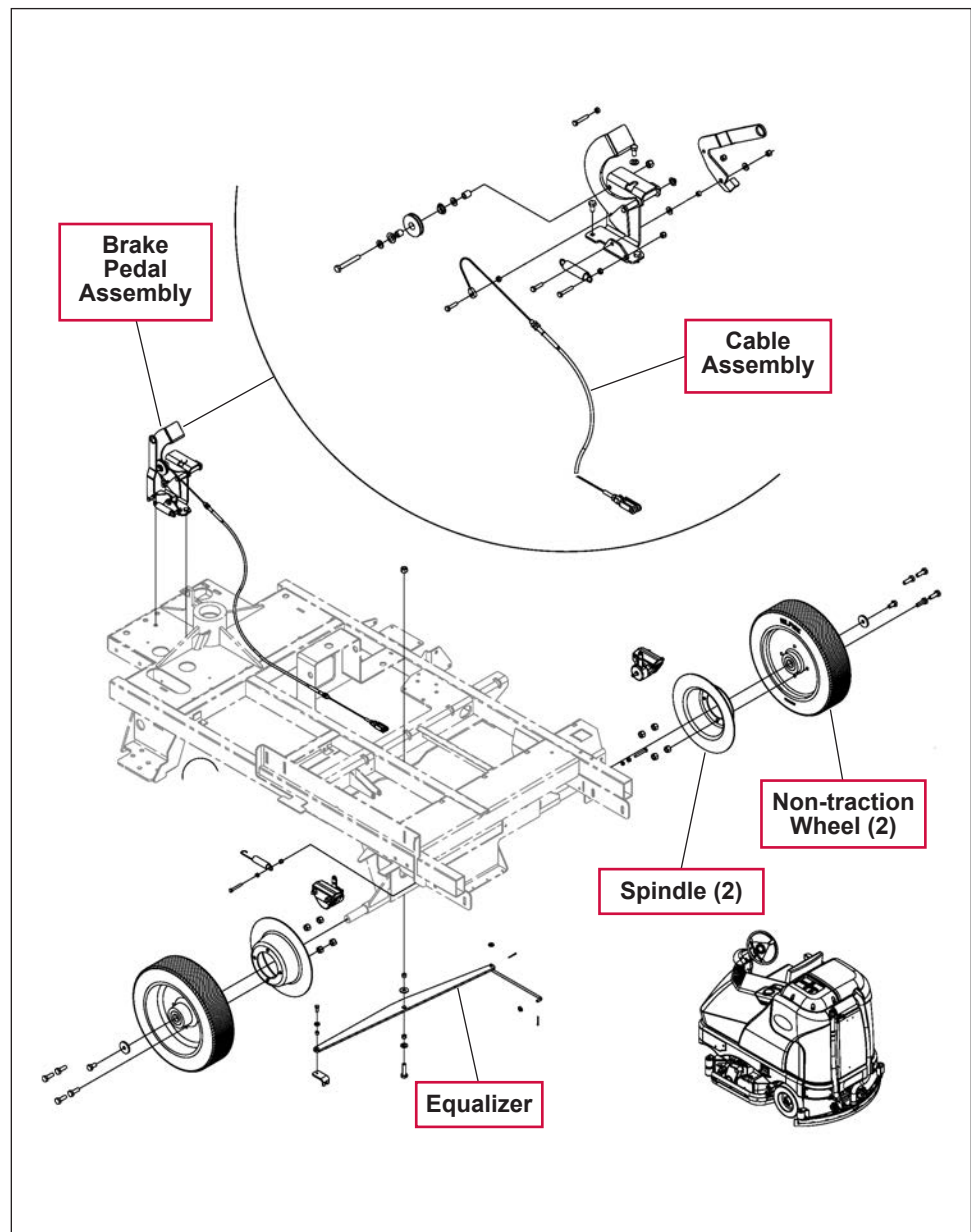

Maintenance and Adjustments



Warning! Before performing any machine maintenance or adjustments, make sure the key switch is off and the key is removed from the machine. Chock both rear wheels so the machine can't roll.

Brake Cable Replacement

1. Remove the floor plate to access the cable assembly at the brake pedal.
2. Loosen the **Locknut** on the cable end **Mounting Bolt**, then remove the **Mounting Bolt** and cable end.
3. Loosen the cable casing **Anchor Nuts** and pull the cable free from its mount bracket on the chassis.
4. Locate a plastic **Tie Strap** on the lower left side of the chassis at midpoint, then cut the **Tie Strap** to free the cable at that point.
5. Unclip the cable **Clevis Yoke** at the left brake caliper at the arm and separate.
6. Loosen the cable **Anchor Locknuts** at the **Equalizer Yoke** mounting bracket. The cable assembly is now completely disconnected.

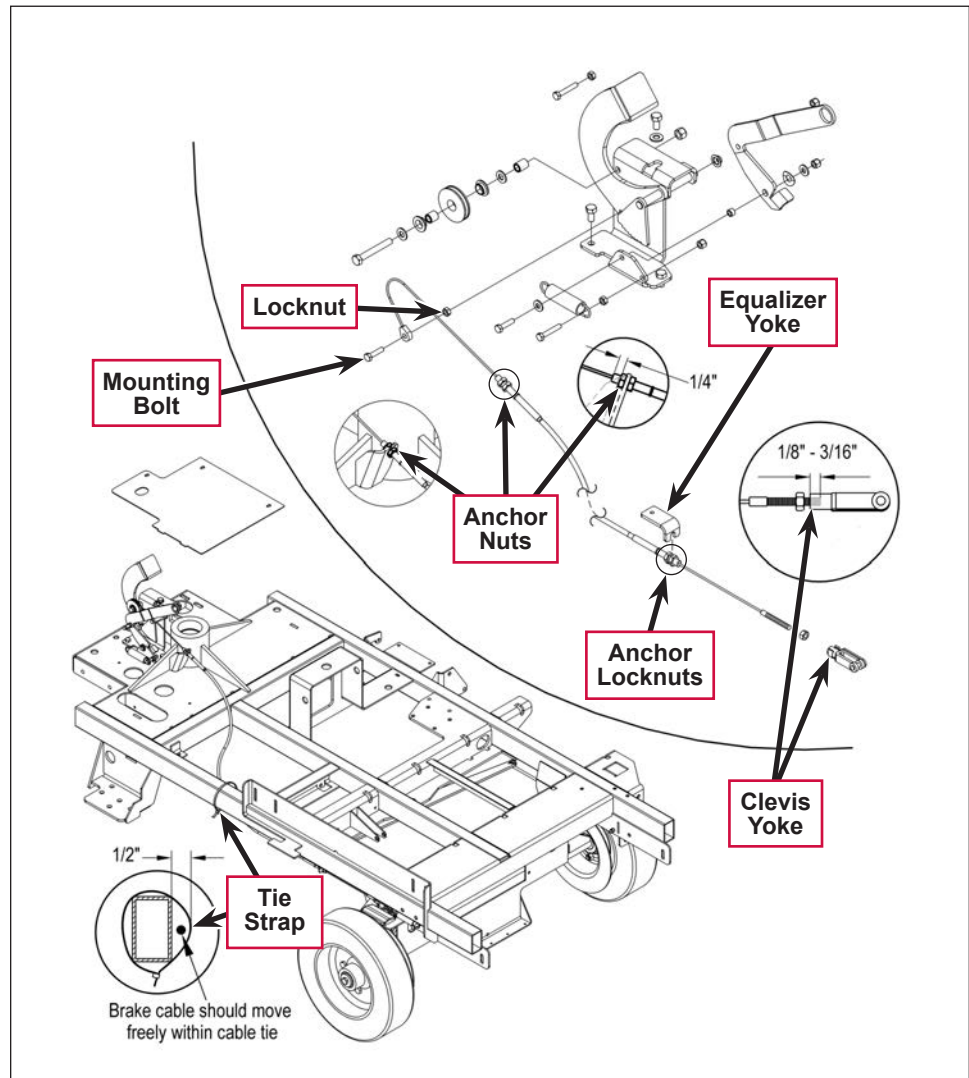

7. Attach a new cable to the end of the old cable at the brake pedal, then pull the old cable out and pull the new cable through the chassis.
8. Follow the above steps in reverse to reconnect the cable.
9. Follow the steps in the **Brake Cable Adjustment** section below to adjust the brake for correct operation.

Brake Cable Adjustment



Caution! Always test-ride the machine after making any adjustments to the brake system to confirm that the braking system is operating correctly.

1. Make sure the parking brake lever is in the released (off) position.
2. Adjust the front brake cable **Anchor Nuts** so $1/4$ " of the threads is exposed as shown, then tighten **Anchor Nuts**.
3. Install a new **Tie Strap** to the chassis as a cable guide. Allow a small amount of cable movement through the **Tie Strap**. There should be about $1/2$ " of clearance between the **Tie Strap** and the chassis as shown.
4. Check that the left rear brake (adjustable) **Clevis Yoke** has about $1/8$ "- $3/16$ " of thread engagement as shown, then tighten the hardware.
5. Adjust the cable at the **Equalizer Yoke** so $1/8$ " of the threads is exposed.
6. Adjust the connection at the **Equalizer Yoke** to obtain a snug brake pedal with no free play, then tighten the **Anchor Locknuts**.

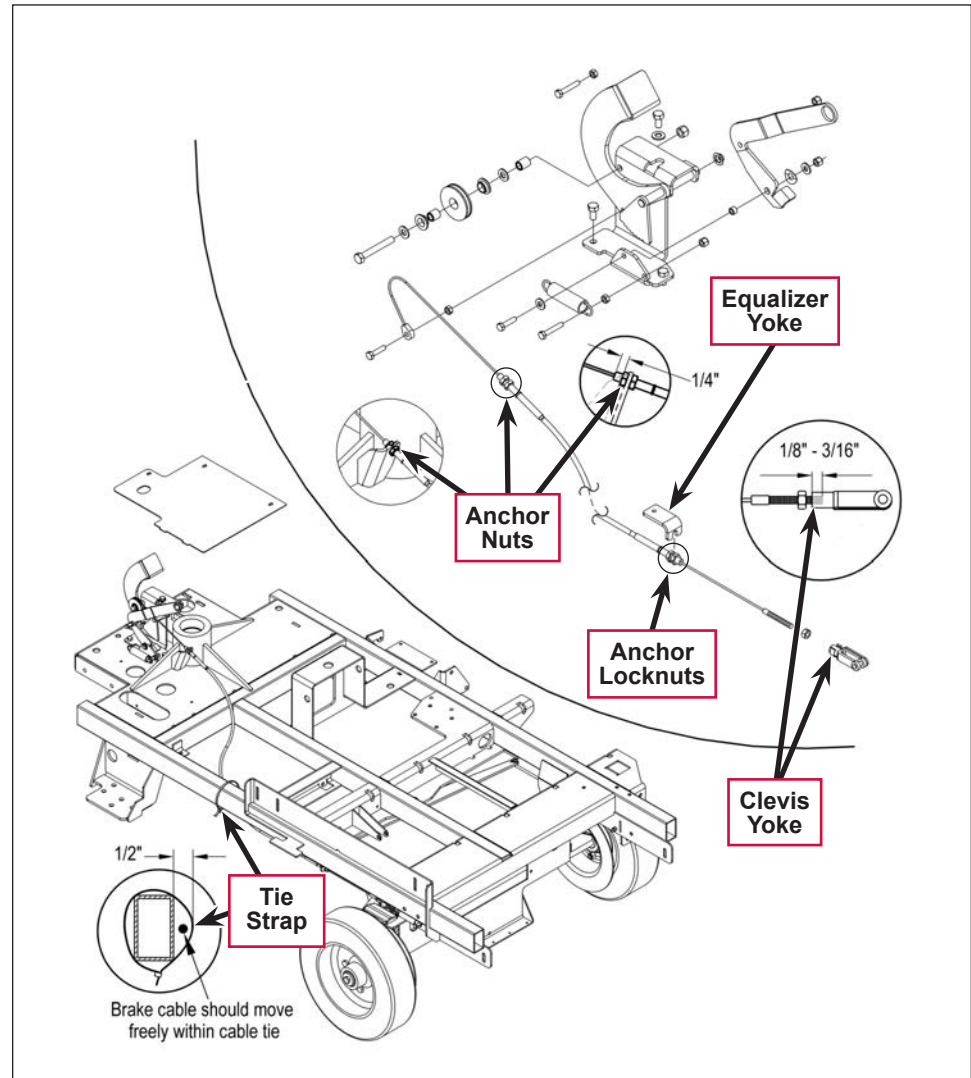

Brake Caliper Pad Wear Adjustment



Caution! Always test-ride the machine after making any adjustments to the brake system to confirm that the braking system is operating correctly.



Note: The **Brake Arm** must not bottom out against the front slot on the caliper.

1. Loosen the large outer **Locknut**.
2. Turn the inner caliper **Adjustment Screw** in to compensate for pad wear.



Note: Do not over-adjust the **Adjustment Screw** to the point where the pad drags excessively against the brake rotor.

3. Tighten the **Locknut**.
4. After making the adjustment, make sure the machine can be pushed easily when the brake pedal is not engaged.

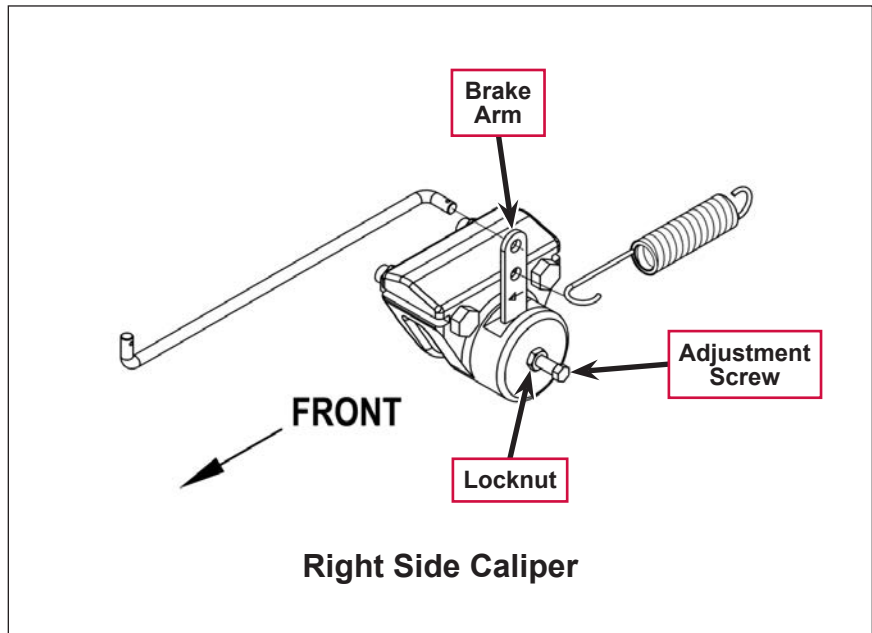

Troubleshooting

Problem	Cause	Correction
Poor braking performance	The brakes are out of adjustment	Adjust the brake cable as necessary. (Refer to the Brake Cable Adjustment section.)
		Adjust the brake caliper to compensate for pad wear. (Refer to the Brake Caliper Pad Wear Adjustment section.)
	Contamination on the brake pads	Clean or replace the brake pads as necessary.

Removal and Installation



Warning! Before removing or reinstalling any machine components, make sure the key switch is off and the key is removed from the machine.

Install wood blocking or chocks in front of and behind the front drive wheel to prevent the machine from rolling.

Rear Wheel and Brake Caliper

1. Grip the brake lever **Return Spring** and pull it back to remove it from the **Retainer Bolt** mounted to the chassis (both right and left wheels).
2.
 - On the left wheel, unclip the brake cable **Clevis Yoke** at the brake arm and remove it from the brake arm mounting hole.
 - On the right wheel, remove the **Cotter Pin** from the **Brake Linkage Rod** and disconnect the **Brake Linkage Rod** from the brake arm mounting hole.
3. Loosen the **M10-1.5 x 20mm Hex Screw** holding the **Rear Wheel** to the axle.

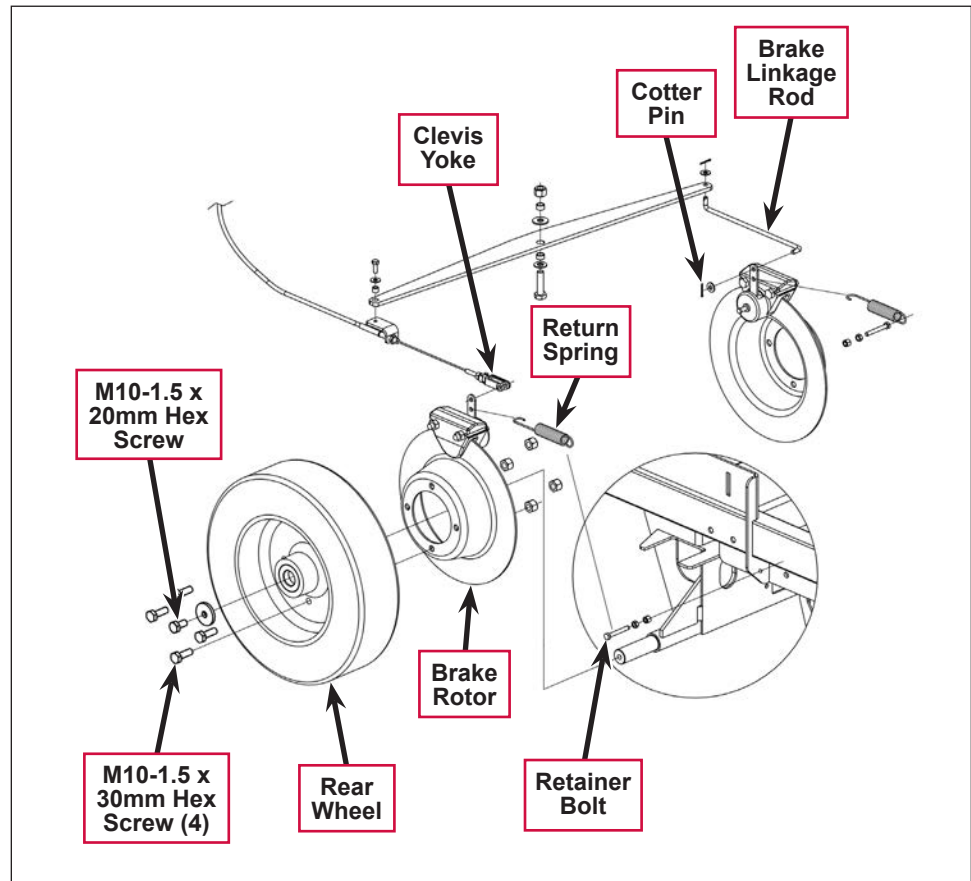

4. Position a suitable jack underneath the wheel axle and jack up the machine so the wheel is approximately 1 inch off the floor.



Warning! Place wood blocking under the rear axle as the machine is only being supported by the jack. This is to prevent any accidents or machine damage when the wheel is off of the machine.

5. Remove the **M10-1.5 x 20mm Hex Screw** and washer and carefully pull the complete wheel and brake assembly off the axle.
6. If you are replacing the wheel:
 - a. Remove the four **M10-1.5 x 30mm Hex Screws** and nuts holding the **Brake Rotor** to the **Rear Wheel** hub.
 - b. Reattach the salvaged **Brake Rotor** to the new **Rear Wheel** hub.

7. To reinstall the wheel and brake assembly:
 - a. Place the brake caliper onto the rotor and align the caliper slots with the chassis.
 - b. Slide the wheel and brake assembly onto the axle.
 - c. Install the **M10-1.5 x 20mm Hex Screw** and washer to fasten the **Rear Wheel** to the axle.



Service Note: Apply a small amount of Loctite 242 (blue) thread sealant to the **M10-1.5 x 20mm Hex Screw** to prevent the screw from loosening.

- d. Remove the wood blocking from the rear axle, then lower the jack.
- e. • Reconnect the brake cable **Clevis Yoke** to the brake arm (left wheel).
• Reconnect the **Brake Linkage Rod** to the brake arm (right wheel) and reinstall the **Cotter Pin**.
- f. Reinstall the **Return Spring** onto the **Retainer Bolt** (both right and left wheels).

Wheel System, Traction

Functional Description

Overview

The traction wheel system includes the drive wheel assembly, Curtis A1 speed controller and associated circuitry, drive wheel steering assembly and the drive pedal assembly.

Drive Wheel Assembly

The 1.75 HP **Drive Motor Assembly** drives the **Poly Front Wheel** to propel the machine.

The **Drive Motor Assembly** has four terminal connections; two armature connections (**A1** and **A2**) and two field connections (**F1** and **F2**). The speed controller provides pulse-width-modulated (PWM) voltage and current output to the motor armature connections (**A1** and **A2**) to control the motor speed, and changes the polarity to the field connections (**F1** and **F2**) to control the motor drive direction.

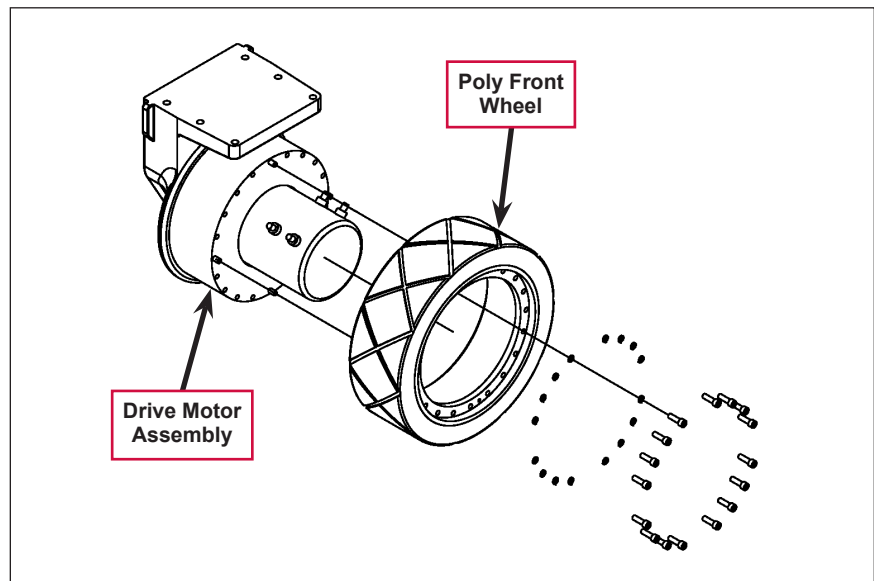

Curtis A1 Speed Controller

The Curtis solid-state speed controller (A1) controls the speed and direction of wheel drive motor according to the inputs it receives from the A2 control board assembly. The speed controller is located to the left of the operator seat behind the electrical access panel.

The speed controller is programmed for two maximum speed setting modes, M1max and M2max.

- The M1max is the transport speed mode and is set at 100% of the total system's speed potential.
- The M2max is the scrubbing speed mode and is set at 70% of the total system's speed potential.

Note that both of the speed settings (M1 and M2) can be changed (increased or decreased) from the original factory specifications only by using the hand-held Curtis programmer. Refer to the **Maintenance and Adjustments/Programming Vehicle Speed Changes** section for instructions on using the programmer for speed setting changes.

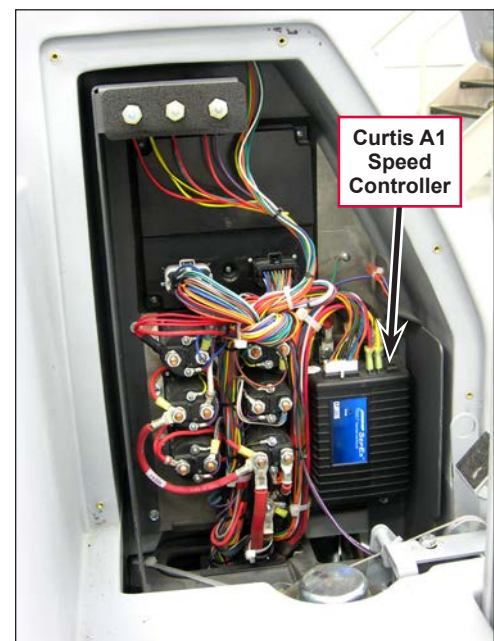

Drive Wheel Steering Assembly

The steering assembly transfers the steering wheel rotation through the steering shafts and universal joint to the **Steer Sprocket** at the bottom of the assembly. The **Steer Sprocket** runs a chain connected to the front spindle weldment to turn the drive wheel left and right.

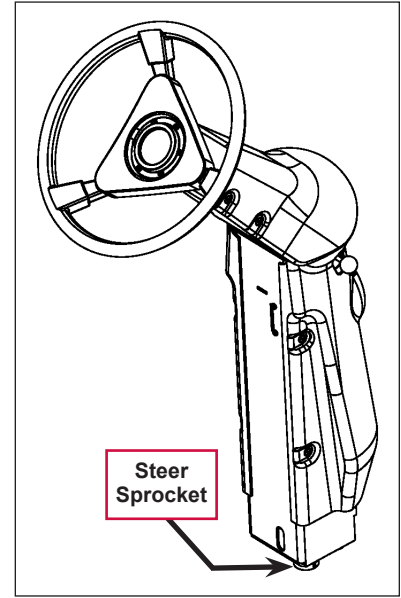

Drive Pedal Assembly

The drive pedal rotates the 5k Ω potentiometer (R1) via the **Link Weldment** and **Throttle Lever** according to the operator's specific drive pedal speed and direction demands. The 5k Ω potentiometer is mounted inside the **Potentiometer Housing**. The A1 Curtis speed controller senses the voltage (0-5 VDC) through the R1 potentiometer to determine the appropriate speed and direction of the wheel drive motor.

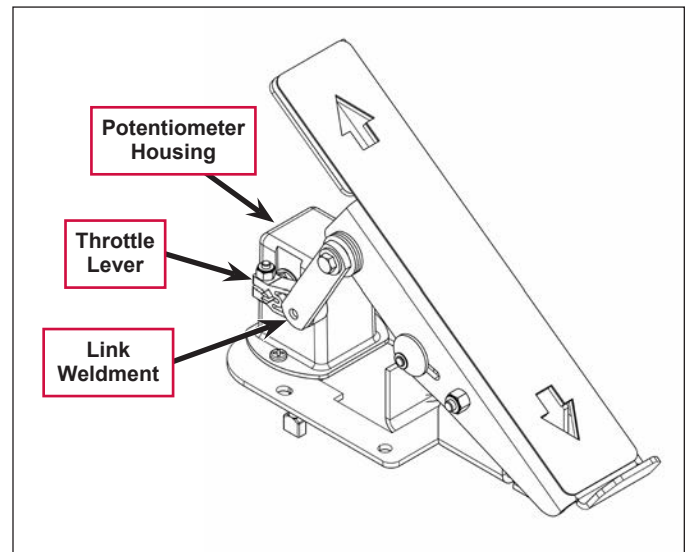

Traction Wheel System Wiring Diagram

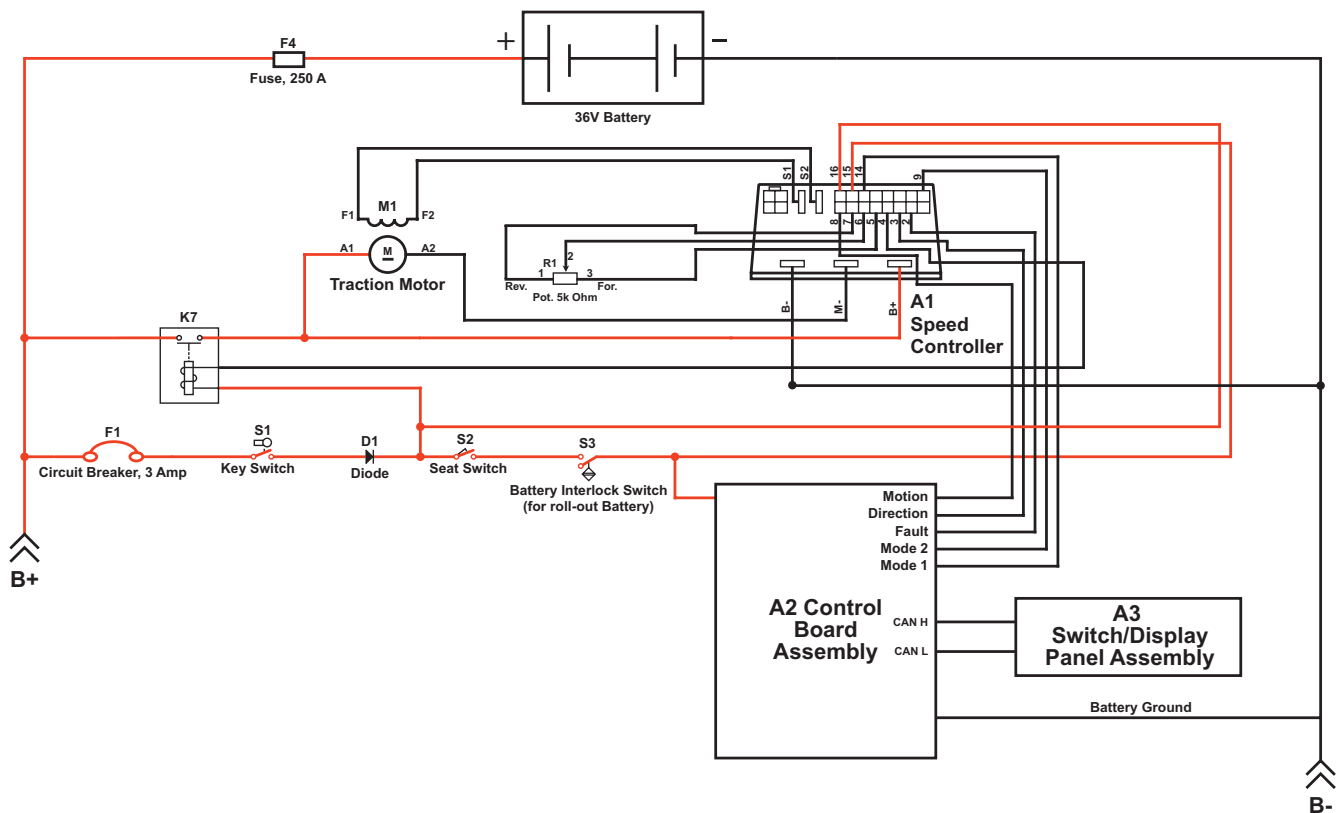

Circuit Description

The **A1 Speed Controller** gets positive voltage from the **Battery** when the load side of contactor **K7** is closed. Contactor **K7** closes when the **Circuit Breaker F1** and **Key Switch S1** are closed. The **A1 Speed Controller** is connected to battery ground.

The **Seat Switch S2** and **Battery Interlock Switch S3** must be closed to provide input to the **A2 Control Board Assembly**.

Moving the drive pedal forward or backward changes the resistance through the **5k Ohm Pot R1**, which changes the 0-5 VDC voltage signal to the **A1 Speed Controller**. Note that 2.5 VDC to the **A1 Speed Controller** is neutral. The **A1 Speed Controller** interprets the input voltage as a direction and percentage of throttle movement, and sends the appropriate voltage to the **Traction Motor M1**. The PWM voltage to the motor armature connections (**A1** and **A2**) controls the motor speed. The polarity of the voltage to the field connections (**F1** and **F2**) controls the motor direction.

Component Locations

Drive Wheel Assembly

The **Drive Wheel Assembly** is located underneath the front of the machine in line with the **Drive Wheel Steering Assembly**.

Curtis A1 Speed Controller

The **Curtis A1 Speed Controller** and **A2 Control Board Assembly** are mounted on the electrical mount to the left of the operator position.

Drive Wheel Steering Assembly

The **Drive Wheel Steering Assembly** is attached to the machine above the **Drive Wheel Assembly**.

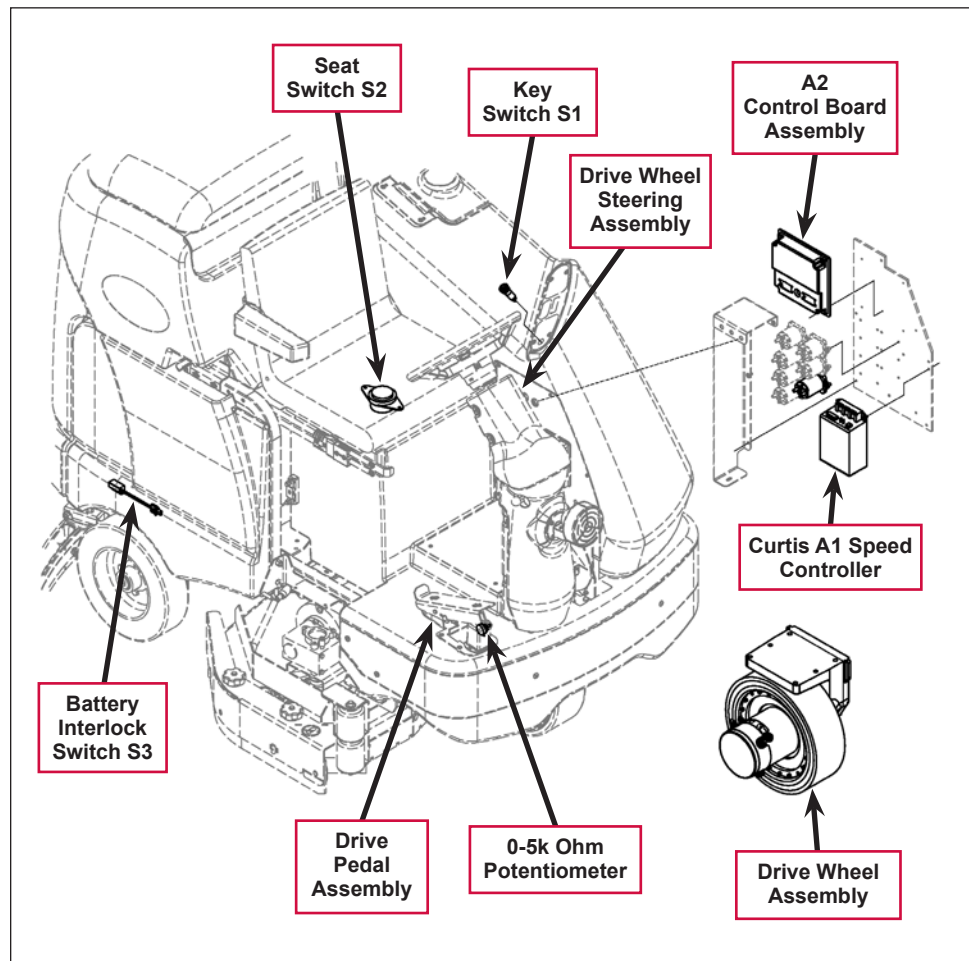

Drive Pedal Assembly

The **Drive Pedal Assembly** is mounted on the floor plate to the operator's right. The **0-5k Ohm Potentiometer** that controls the drive motor speed and direction is housed in the **Drive Pedal Assembly**.

Interlock Switches

- **Key Switch S1** – main power switch, mounted on the control panel.
- **Seat Switch S2** – closes when the operator is in the seat.
- **Battery Interlock Switch S3** – closes when the roll-out battery is in the normal operating position.

Maintenance and Adjustments



Warning! Before performing any machine maintenance or adjustments, make sure the key switch is off, the key is removed from the machine and the parking brake is engaged.

Steering Chain

1. Inspect the chain for looseness and binding.
2. Adjust the chain tension to 3/16" - 1/4" [4.7- 6.4 mm] deflection by following the instructions in the **Removal and Installation/Steering Chain Removal and Tensioning** section.
3. Keep all of the steer chain links greased to prevent excessive wear and binding.

Curtis Speed Controller

There are no user-serviceable parts inside the Curtis PMC 1243 controller. No attempt should be made to open the controller. Opening the controller may damage it and will void the warranty.

However, it is recommended that the controller exterior be cleaned periodically. If a handheld programmer is available, this periodic cleaning provides a good opportunity to check the controller's diagnostic history file.

Programming Vehicle Speed Changes

The maximum high speed M1 (transport) and maximum low speed M2 (scrub) can be changed electronically using the handheld programmer. To change a parameter using the programmer:

1. Press the **PROGRAM** key and scroll down the Program Menu until the desired parameter is the top line of the display.
2. Press the appropriate **CHANGE VALUE** key (up or down) until the desired number is reached. The parameter is now set at the desired value.

All programming occurs in real time. In other words, the parameters can be changed while the vehicle is in operation. The upper and lower limits of parameters are set at the factory.

Some parameters have dependencies on other parameters. When the programmer is being used to adjust a parameter and a limit is reached, the display will stop changing. To see why the display has stopped changing, press the **MORE INFO** key. If the limit is related to another parameter, that information will be displayed. Changing the value of the related parameter may allow the original parameter to be adjusted further. Otherwise, the display simply says **Max Limit** or **Min Limit**.

Use of the programmer models 1307 (old style) and 1311 (new style) is described more fully in the Curtis Programmer manual 56043101.

Troubleshooting

General Troubleshooting

Problem	Cause	Correction
Wheel drive motor will not run in forward and reverse.	Batteries need charging (low battery voltage).	Recharge the batteries.
	Control Circuit Breaker (F1) is tripped.	Reset the circuit breaker.
	The parking brake is engaged.	Release the parking brake.
	The emergency-stop/battery disconnect is disengaged.	Reengage the emergency-stop/battery disconnect.
	The seat switch (S2) is not closed.	Check the seat switch and repair/replace as necessary.
	Defective battery roll-out interlock switch (S3).	Adjust/replace switch as necessary.
	Defective wheel drive motor.	Replace the motor.*
	Defective throttle potentiometer (R1).	Replace the throttle pot.*
The wheel will only drive in one direction; loss of either forward or reverse.	Defective main contactor (K7).	Replace contactor K7.
	The A1 speed controller can't change the electrical polarity to the wheel motor at the field terminals S1 and S2.	Check the A1 speed controller.
The hourmeter/status display shows an error 03 fault code.	The A1 speed controller has sensed an operation error code fault.	Refer to the Status LED Fault Codes section.

* See the **Curtis Controller Diagnostics** section.

Curtis Controller Diagnostics

Diagnostics Method A

Method A uses the machine's control display LCD panel and detergent system LED indicator.

The Curtis speed control will output a fault code if there is a problem associated with the speed control and wheel drive system. If a speed control fault occurs, the display LCD panel will indicate **03**.

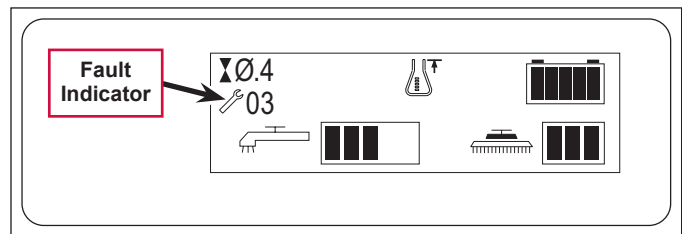

When the **03** error code is displayed and detects a fault, the detergent system indicator LED will flash a special error code sequence until the fault is corrected. Refer to the **Status LED Fault Codes** section for a description of the fault indications.



Service Note: Instructions on how to read the error code flashes on the detergent system indicator: For example, OO O = two light flashes, a short pause, one flash, a long pause, then the code will be repeated. This indicates fault code 2,1.

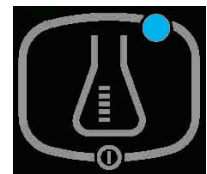

Diagnostics Method B

Method B uses the optional hand-held Curtis programmer model 1307, or the new model 1311 MP1101.

With a programmer, diagnostics and troubleshooting is more direct than with the detergent system LED indicator alone. The programmer presents complete diagnostic information in plain language with no codes to decipher. Faults are displayed in the Diagnostic Menu, and the status of the controller inputs/outputs is displayed in the Test Menu.

The following four-step process is generally used for diagnosing and troubleshooting an inoperative vehicle:

1. Visually inspect the vehicle for obvious problems.
2. Diagnose the problem using the programmer.
3. Test the circuitry with the programmer.
4. Correct the problem. Repeat the last three steps as necessary until the vehicle is operational.

For example: A vehicle that does not operate in “forward” is brought in for repair.

1. Examine the vehicle and its wiring for any obvious problems such as broken wires or loose connections.
2. Connect the programmer, put it in diagnostic mode and read the displayed fault information. In this example, the display shows “No Faults Present”, indicating that the controller has not detected anything out of the norm.
3. Put the programmer in the test mode and observe the status of inputs and outputs in the forward direction. In this example, the display shows that the forward input did not activate when “forward” was selected, which means the problem is either in the electronic throttle or the throttle wiring.
4. Check or replace the electronic throttle and wiring and repeat the test. If the programmer shows the forward switch closing and the vehicle now drives normally, the problem has been corrected.

Refer to the **Status LED Fault Codes** section for suggestions covering a wide range of possible faults.

Diagnostic History

The handheld programmer can be used to access the controller’s diagnostic history file. Connect the programmer, press the **MORE INFO** key. While continuing to hold the **MORE INFO** key, press the **DIAGNOSTICS** key. The programmer will read out all the faults that the controller has experienced since the last time the diagnostic history file was cleared. The faults may be intermittent faults, faults caused by loose wires or faults caused by operator errors. Faults such as HPD or over-temperature may be caused by operator habits or by overloading.

After a problem has been diagnosed and corrected, it’s advisable to clear the diagnostic history file. This allows the controller to accumulate a new file of faults. By checking the new diagnostic history file at a later date, you can readily determine whether the problem was indeed completely fixed.



To clear the diagnostic history file, go to the Special Program Menu (by pressing and holding the **MORE INFO** key, and then pressing the **PROGRAM** key). Scroll through the menu until **Clear Diagnostic History** is the top line in the display, then press **MORE INFO** again. The programmer will prompt you to acknowledge or cancel.

See the Curtis programmer manual 56043101 for more detail on programmer operation.



Service Note: *The text used above in the descriptions of the Curtis programmer usage is that used for the original (older) model 1307. Reference the manual 56043101 for the correct usage terminology for the new model programmer 1311.*

Status LED Fault Codes

LED Code	Status Light Display	Explanation	Possible Cause
Off		No power or defective controller	
Solid On		Controller or microprocessor fault	
0,1	0 (single LED flash every 5 seconds)	Controller operational; no faults	
1,1	0 0	Current sensor error	Controller defective.
1,2	0 00	Hardware fail-safe error	Controller defective.
1,3	0 000	M- fault or motor output short	Internal M- short to B-. Controller defective.
1,4	0 0000	SRO fault	<ol style="list-style-type: none"> 1. Incorrect sequence of KSI*, interlock (seat switch), and direction inputs. 2. Wrong SRO type selected. 3. Interlock or direction switch circuit open. 4. Sequencing delay too short.
2,1	00 0	Throttle wiper fault	<ol style="list-style-type: none"> 1. Throttle input wire open. 2. Throttle input wire shorted to B+ or B-. 3. Throttle pot defective. 4. Wrong throttle type selected.
2,3	00 000	HPD fault	<ol style="list-style-type: none"> 1. Incorrect sequence of KSI*, interlock, and throttle inputs. 2. Wrong HPD type selected. 3. Throttle pot not adjusted correctly. 4. Sequencing delay too short.
2,4	00 0000	Pot low input fault	<ol style="list-style-type: none"> 1. Throttle pot wire open. 2. Throttle pot wire shorted. 3. Wrong throttle type selected.
3,1	000 0	Contact driver overcurrent or field winding shorted	<ol style="list-style-type: none"> 1. Main contactor coil shorted. 2. Field winding shorted.
3,2	000 00	Main contactor welded	<ol style="list-style-type: none"> 1. Main contactor stuck closed. 2. Main contactor driver shorted.
3,3	000 000	Motor field winding open	<ol style="list-style-type: none"> 1. Field winding connection open. 2. Field winding open.
3,4	000 0000	Missing contactor	<ol style="list-style-type: none"> 1. Main contactor coil open. 2. Main contactor missing. 3. Wire to main contactor open.

LED Code	Status Light Display	Explanation	Possible Cause
4,1	0000 0	Low battery voltage	<ol style="list-style-type: none"> 1. Battery voltage <under-voltage cutback limit. 2. Corroded battery terminal. 3. Loose battery or controller terminal.
4,2	0000 00	Over-voltage	<ol style="list-style-type: none"> 1. Battery voltage >over-voltage shutdown limit. 2. Vehicle operating with charger attached.
4,3	0000 000	Over / Under-temp. cutback	<ol style="list-style-type: none"> 1. Temperature >85°C (185°F) or <-25°C (-13°F). 2. Excessive load on vehicle. 3. Incorrect mounting of controller. 4. Operation in extreme environments.
4,4	0000 0000	Anti-tie-down fault	<ol style="list-style-type: none"> 1. Mode switches shorted to B+. 2. Mode switches “tied down” to select Mode 2 or Mode 4 permanently.

***Note:** A KSI (key switch input) system problem is a specific HPD (high pedal disable) type operational fault, caused by the operator activating the forward/reverse drive pedal before turning on the main key switch, or activating the throttle before sitting on the seat. This can be cleared by returning the operator’s drive pedal to neutral and cycling the key switch off and on.

Removal and Installation



Warning! Before removing or reinstalling any machine components, make sure the key switch is off, the key is removed from the machine and the parking brake is engaged.

Steering Chain Removal and Tensioning

1. Turn the master key switch off and disconnect the battery pack emergency-stop/battery disconnect.
2. Loosen the four **Screws** from underneath the front of the machine and push the **Lower Steering Column** toward the rear of the machine. This will allow you to separate the **Chain** from the **Steer Sprocket**.
3. Remove both **Master Links** that secure the **Chain** to the **Steer Plate** then remove the **Chain** from the chassis.
4. Reinstall the **Chain** by following the above steps in reverse order.
5. Adjust the **Chain** tension so there is about 3/16" – 1/4" [4.7 – 6.4mm] total deflection with moderate pressure applied at the **Midpoint** as shown.

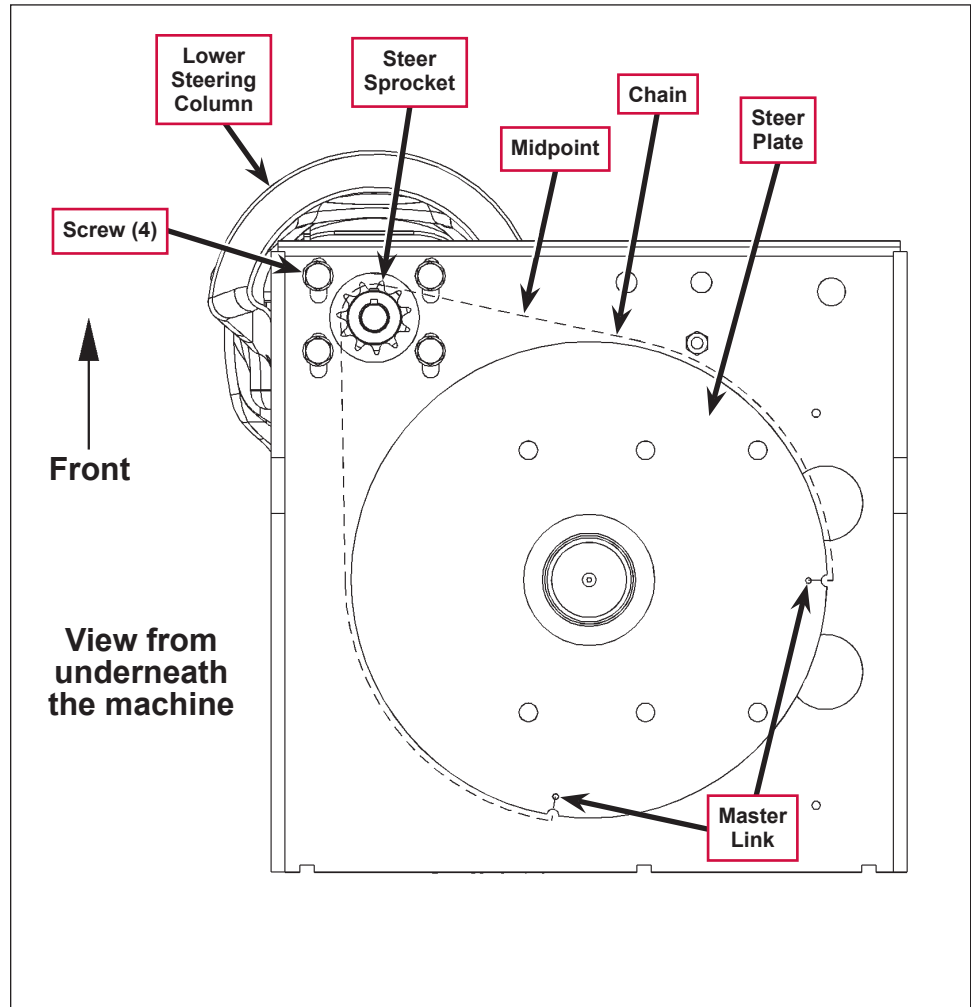

Service Note: Use a pry bar or shims between the chassis and steer column to help secure the tension adjustment when tightening the four steering column mounting **Screws**.

Front Drive Tire



Note: It is not necessary to remove the complete wheel drive/spindle assembly to service the drive tire only.



Warning! Turn the key switch off and disconnect the battery pack by pushing in the emergency-stop/battery disconnect red lever.

Engage the machine parking brake and block both rear wheels so machine can't roll.

Never work under machine without safety stands or blocking to support the machine.

1. Observe the four motor wires and note their colors and their correct terminal connections for reassembly.
2. Remove the four motor wires from the motor terminals as shown using a 7/16" wrench for the two small terminals, and a 1/2" wrench on the large terminals.

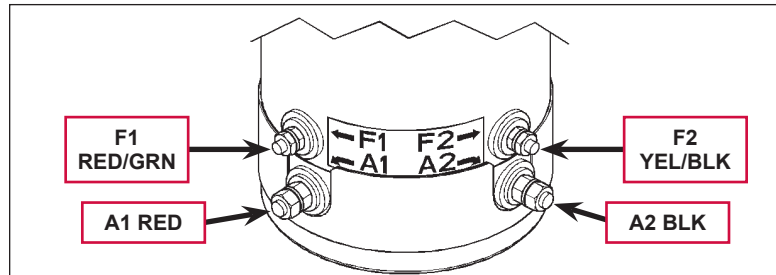

Service Note: When you disassemble or reassemble the wire terminal connecting hardware, use an extra wrench to help prevent the electrical motor stud(s) from rotating to prevent damage to the internal motor leads.

3. Remove the 16 **5/16"- 24 Socket Head Cap Screws** from the rim (use a 1/4" hex drive socket).
4. Safely jack up or lift the front of the machine 1 to 2 inches [25-50 mm] and block both front machine corners.
5. Locate the two tapped holes laid out 180 degrees apart found on the tire rim. Thread two **1/4"-20 Hex Head Screws** into the tapped holes, then turn the **Screws** equally to push apart (separate) the **Tire** from the **Gear Housing**.
6. To install a **Tire**, clean the tire rim and drive drum, then apply a small amount of Never-Seez® to the back side of the rim.
7. Reinstall the 16 **5/16"- 24 Socket Head Cap Screws** and torque the **Screws** to 24-26 ft-lbs [32-35 Nm].

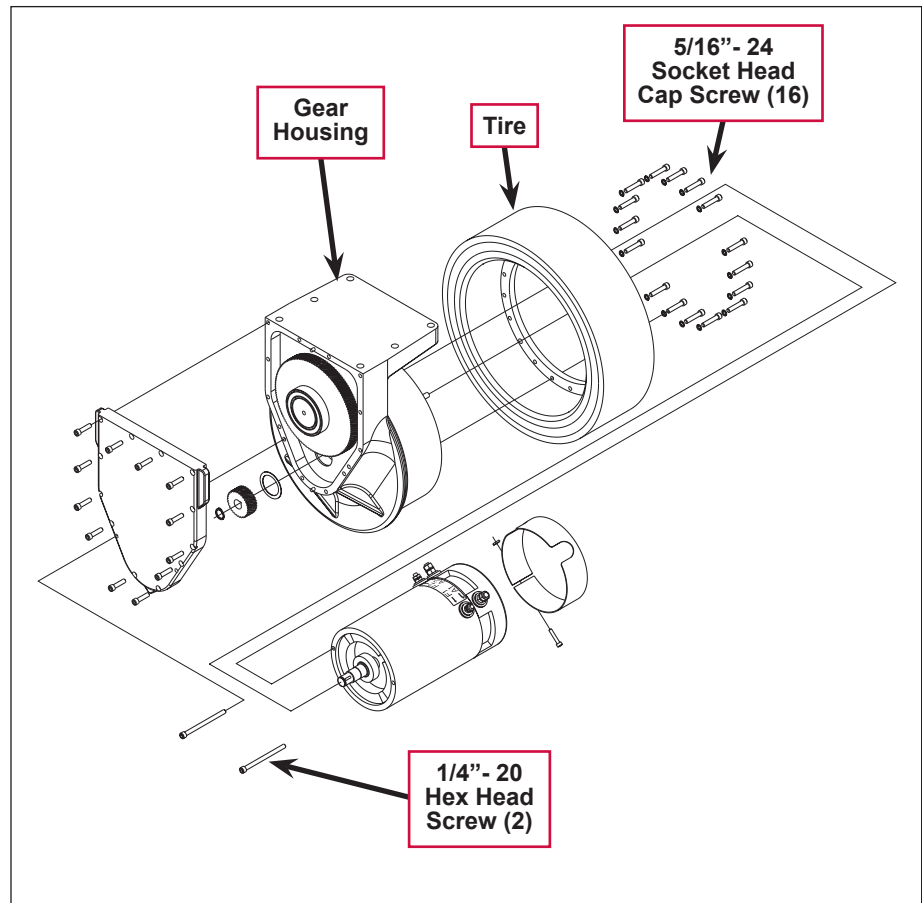

Steering Spindle and Wheel Drive Assembly



Warning! Turn the key switch off and disconnect the battery pack by pushing in the emergency-stop/battery disconnect red lever.

Engage the machine parking brake and block both rear wheels so machine can't roll.

1. Observe the four motor wires and note their colors and their correct terminal connections for reassembly.
2. Remove the four motor wires from the motor terminals as shown using a 7/16" wrench for the two small terminals, and a 1/2" wrench on the large terminals.

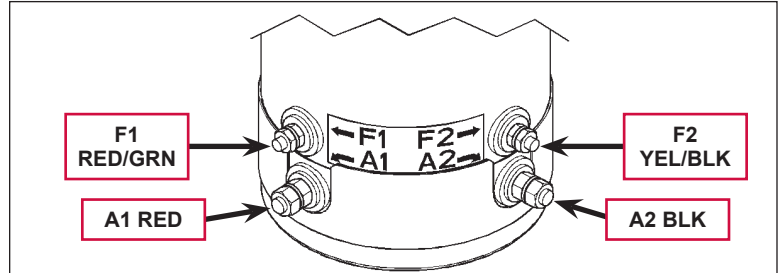

Service Note: When you disassemble or reassemble the wire terminal connecting hardware, use an extra wrench to help prevent the electrical motor stud(s) from rotating to prevent damage to the internal motor leads.

3. Remove the hex screw and nut holding the motor wiring harness **P-clamp** (use a 7/16" wrench), then pull wiring to the rear of the machine.
4. Loosen the four **Screws** from underneath the front of the machine and push the lower steering column toward the rear of the machine. This will allow you to separate the **Chain** from the **Steer Sprocket**.
5. Remove the false floor plate in the operator compartment (held with three screws) to allow access to the top spindle mounting hardware.
6. Remove the **Bearing Dust Cap**, **Cotter Pin** and **Castle Nut** from the spindle shaft.

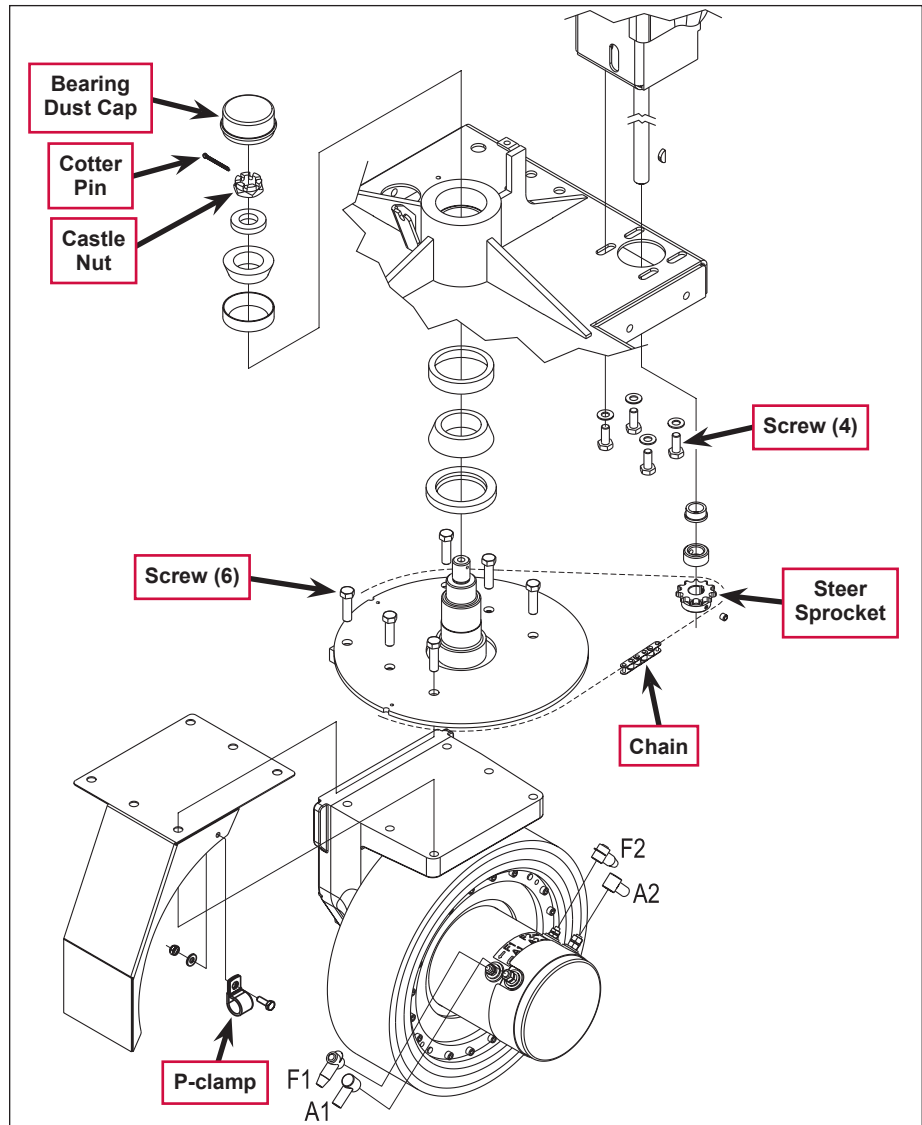



Warning! Never work under machine without safety stands or blocking to support the machine.

7. Safely jack up or lift up the front of the machine 8-10 inches [20-25 cm] from the center bottom edge of the solution tank.
8. Carefully guide the wheel motor assembly down and out of its frame opening. Tilt the wheel motor assembly to the side while raising the machine, then pull it out from underneath the machine.



Note: Be careful not to damage the threads and bearing surfaces when dropping the spindle shaft down through the frame when removing it from the chassis.

9. Inspect the bearings and seal and replace as needed. If further service work is needed, remove the six **Screws** to separate the spindle/steer plate weldment and splash fender from the gear box housing. Also refer to the **Electric Drive Motor** section.
10. Reassemble the steering spindle and wheel drive assembly by following the above steps in reverse order.



Note: Tighten the **Castle Nut** to eliminate any bearing play, then back off the **Castle Nut** enough to install a new **Cotter Pin**.

Electric Drive Motor

1. Follow steps 1 through 9 in the **Steering Spindle and Wheel Drive Assembly** section.

2. Remove the 12 **Gear Case Cover Screws** (two long and 10 short) holding the **Gear Case Cover** to the large **Gear Housing** (use a 3/16" hex driver socket).

3. Separate (pry) the **Gear Case Cover** from the **Gear Housing** by tapping on the three casting ear corners on the **Gear Case Cover**.

4. Use a snap ring pliers to remove the **Retainer Ring**, then pull the small **Motor Gear** from the end of the motor shaft.

5. Separate the **Motor Assembly** from the **Gear Housing**.

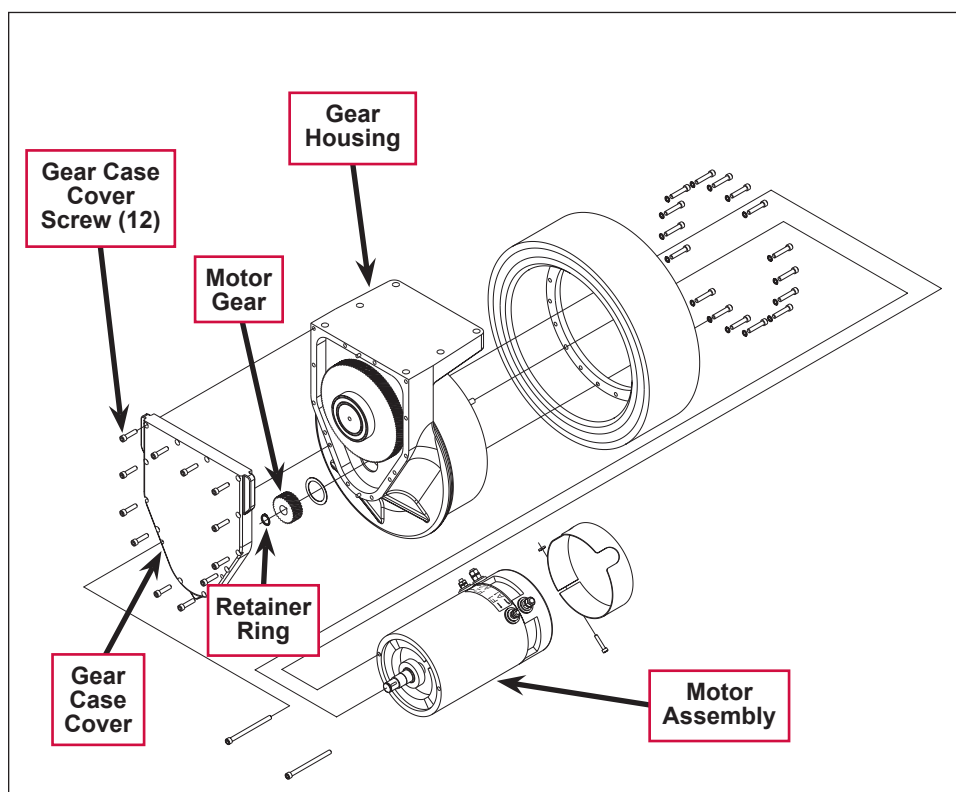

6. Reinstall the **Motor Assembly** by following the above steps in reverse order. Torque the 12 **Gear Case Cover Screws** to 10 ft-lbs [13 Nm].

Carbon Motor Brush Inspection and Replacement



Warning! Turn the key switch off and disconnect the battery pack by pushing in the emergency-stop/battery disconnect red lever.

Engage the machine parking brake and block both rear wheels so machine can't roll.

1. To inspect the carbon brushes (quantity of four) for brush wear and length, remove the **Socket Head Cap Screw** (using a 1/8" hex wrench), then separate the metal **Inspection Band** from the motor end bell.

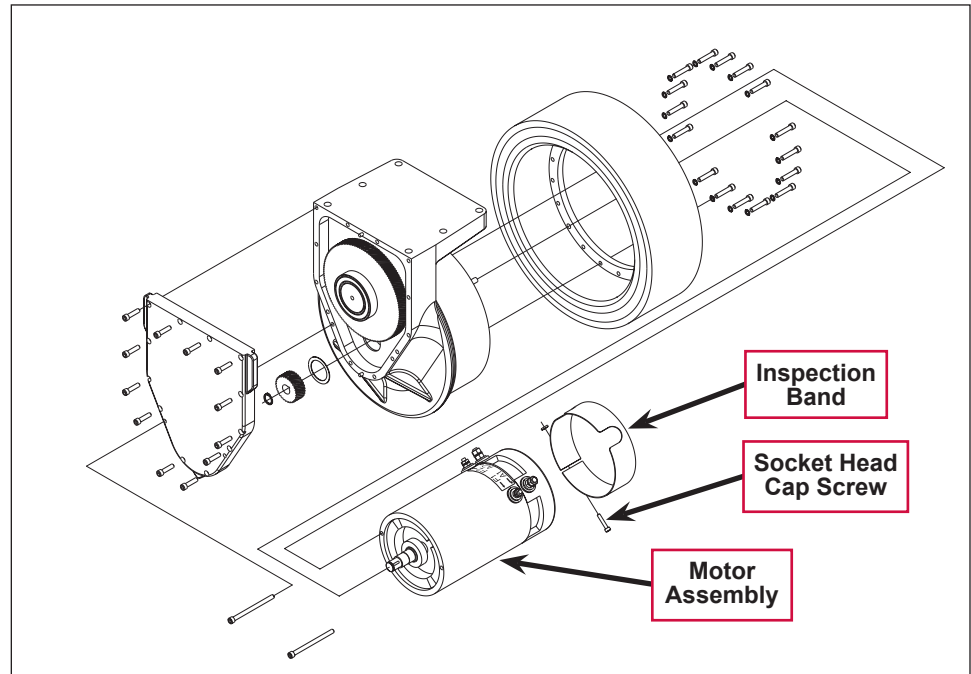

Service Note: Bend a sharp loop in the end of a stiff piece of wire to fabricate a tool to pull on the end of the carbon brush spring tail to easily help apply or remove the spring tension on the end of a carbon brush.

2. Remove the spring tension on the end of each brush using the above mentioned tool, and then pull the brush from the holder to examine and measure it. A new brush measures 1 inch (25.4 mm) in length. If a brush is less than 3/8 inch (10 mm) in length, replace it.



Note: Each brush has a wire end secured to the brush ring with a small hex screw. Use a 5/16" socket to remove the screw.

Potentiometer Removal and Testing



Warning! Turn the key switch off and disconnect the battery pack by pushing in the emergency-stop/battery disconnect red lever.

Engage the machine parking brake and block both rear wheels so machine can't roll.

Potentiometer Removal

- Remove the five **Screws** holding the drive pedal mount assembly to the chassis, then carefully lift the pedal assembly up and lay it on its side.
- Observe the three wires connected to the drive pedal **Potentiometer** (pot), and also the single GRN/YEL throttle **Ground Wire**. Note the correct wire colors and their terminal connections for reassembly.
- Disconnect the wiring and remove the pedal mount assembly from the machine.
- Remove the **Link Rod** from the **Pedal**. Be careful not to lose the link rod **Mounting Hardware** items.
- Loosen the **Nut** and **Screw** at the drive pedal **Throttle Lever**, then pry the **Throttle Lever** off of the end of the **Potentiometer** shaft.
- Remove the **Potentiometer** from the **Mount Housing**.

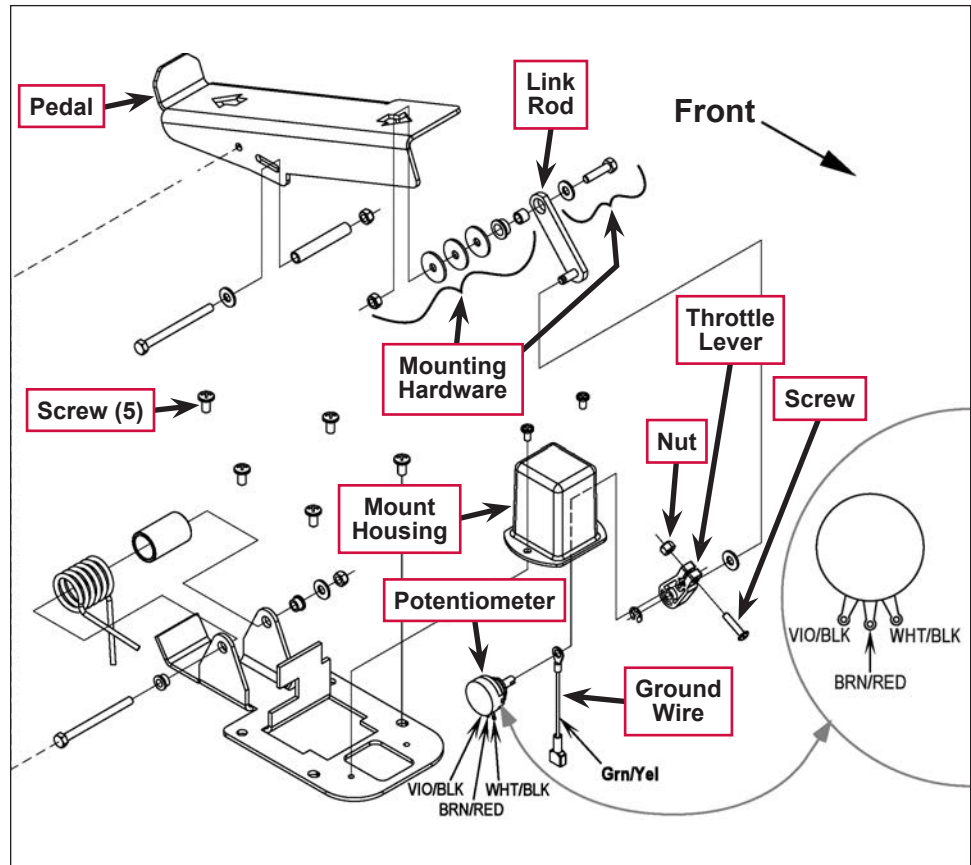

Potentiometer Testing



Note: The pot doesn't have to be removed from the housing to test.

- Test the **Potentiometer** using an ohmmeter (the pot specification is 5K Ohms).
- Connect the meter leads to each of the outside connections on the **Potentiometer**. The meter should read approximately 5000 Ohms (plus or minus 500 Ohms).

- Move one of the test leads to the middle connection and turn the stem in both directions. The range of the readings should be approximately 1300-2500 Ohms or 2500-3700 Ohms, increasing and decreasing through its full range.
- If you do not get these readings, replace the **Potentiometer**.



Service Note: A simple shortcut method for testing and adjusting the pot resistance values is at the 16 pin plug on the speed controller. Just disconnect the plug and back-probe pins 5, 6 and 7 (wire colors VIO/BLK, BRN/RED and WHT/BLK). The controller can be easily accessed by removing the electrical panel door located to the left of the operator position.

Potentiometer Installation and Adjustment



Warning! The potentiometer adjustment sets the drive pedal for a neutral drive motor operation. If the pot is not adjusted correctly, the machine will creep in either forward or reverse.

- Install the **Potentiometer** into the **Mount Housing** and tighten the attachment nut.
- Loosely connect both the **Link Rod** to the **Pedal**, and the **Throttle Lever** to the **Potentiometer** input shaft.
- Tighten the **Link Rod pedal Mounting Hardware** only. Check the **Pedal** movement. It must move freely in both forward and reverse.
- See the **Potentiometer** terminal detail. Attach test leads from a volt/ohm meter to the VIO/BLK and WHT/BLK wire connection points on the **Potentiometer** to check its total resistance (for example 4800 Ohms).

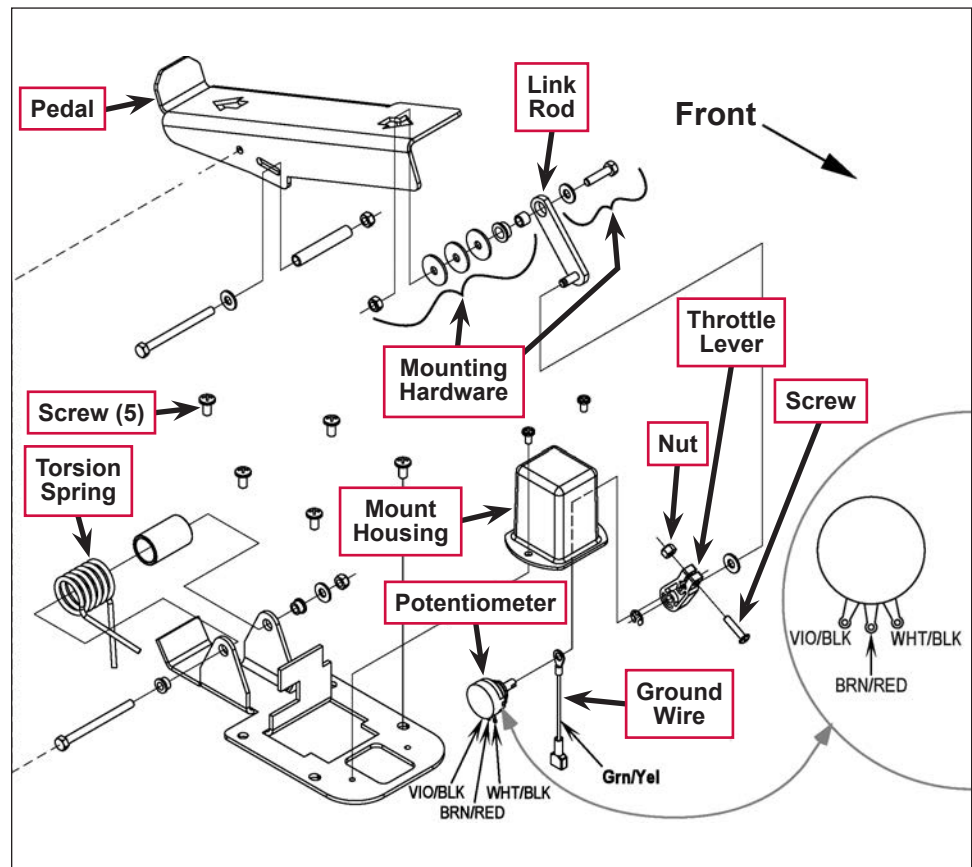

- Connect the ohmmeter test leads to the VIO/BLK and BRN/RED **Potentiometer** connection points. Use a small screwdriver to turn the shaft end on the **Potentiometer** to half the total resistance previously measured. For example: 4800 Ohms divided by 2 = 2400 Ohms. Then, without turning the shaft, tighten the **Screw** and **Nut** to secure the setting at the **Throttle Lever**.

6. Reconnect the three wires to the **Potentiometer** and the single GRN/YEL throttle **Ground Wire**. Make sure the wires are connected to the correct terminals as was noted when the drive pedal was removed.
7. Reinstall the drive pedal mount assembly onto the chassis, the reinstall and tighten the five **Screws**.
8. Test-drive the machine to check for correct speed and forward/reverse directional control.



Service Note: Also confirm the Hourmeter/Status Display is free of the error code 03 (drive system fault). If error 03 is shown, the throttle is not set correctly for the potentiometer and/or drive pedal neutral position. Check both again and readjust.

Alternate Method for Throttle Adjustment

The throttle adjustment is easier and more accurately adjusted by measuring the throttle potentiometer wiper voltage with respect to B (-).

To set throttle neutral:

1. Connect a voltmeter to B (-) on the speed controller and to the BRN/RED wire. A thin probe can be inserted into the connector at pin 6 on the speed controller, or an insulation piercing probe can be used on the BRN/RED wire.
2. Adjust the throttle potentiometer to 2.50 +/- .05 volts with the throttle pedal in neutral. This will ensure that the throttle is centered on neutral, and there is 100% throttle when the pedal is fully depressed in the forward direction. A Curtis programmer can be used to check that there is 100% throttle in forward.

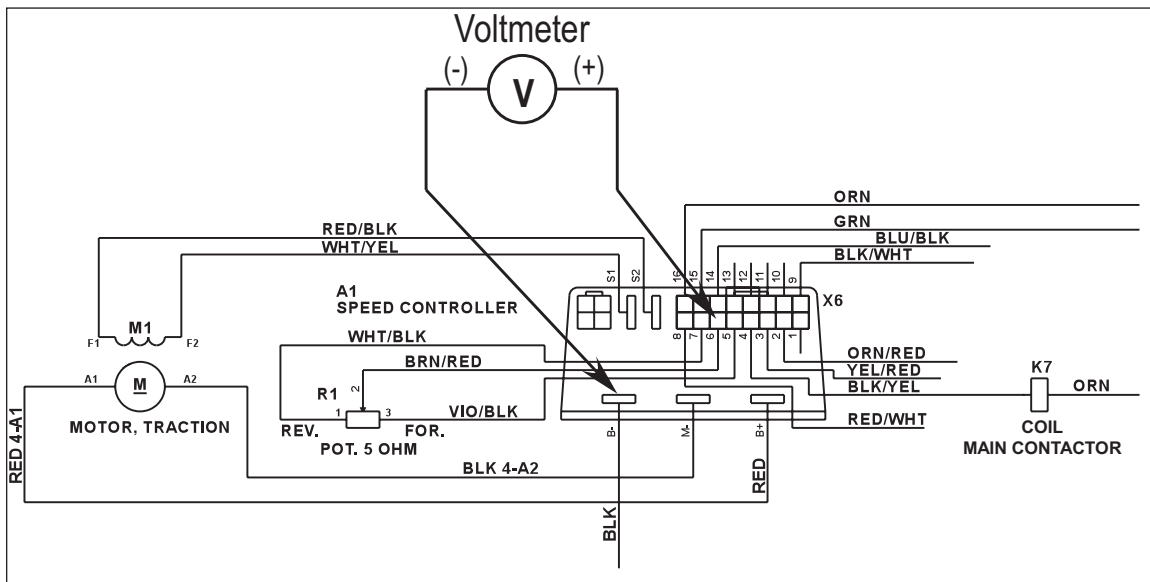

Drive Pedal Neutral Adjustment and Pedal Replacement

If the drive pedal has been removed or replaced, the pedal neutral position will have to be set. Follow the steps below to accomplish this.



Warning! Turn the key switch off and disconnect the battery pack by pushing in the emergency-stop/battery disconnect red lever..



Note: Before making any adjustments, inspect the **Torsion Spring** for defects and for the correct positions of both spring ends. (See the figure on the following page.) If the **Torsion Spring** is damaged, replace it.

To Adjust the Pedal Spring

1. Loosen the **Screw** and **Nut**. The **Screw** and **Bushing** are positioned between both forward and reverse torsion spring ends. Their position controls the needed pre-load pressure to eliminate excessive pedal free-play, and provides a balanced spring rate to return the pedal to a centered (neutral) position.
2. Push the **Screw** back into the pedal frame slot to increase spring tension and eliminate pedal free play.
3. Tighten the **Screw** and **Nut**. Be careful not to pull on the linkage connection to the pot shaft and disturb (move) its neutral setting.

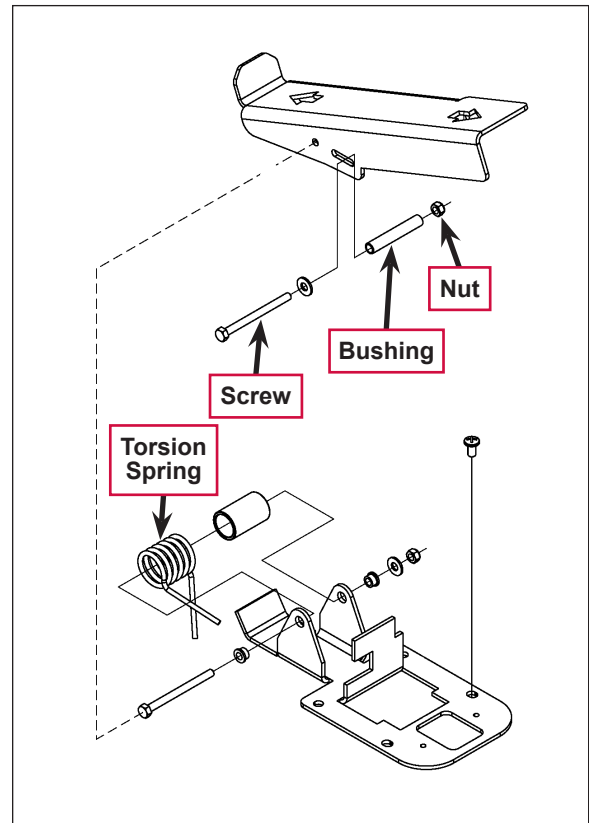

To Replace the Pedal or Spring

1. Position the **Torsion Spring Ends** as shown. This is with the **Bushing** and screw not installed.

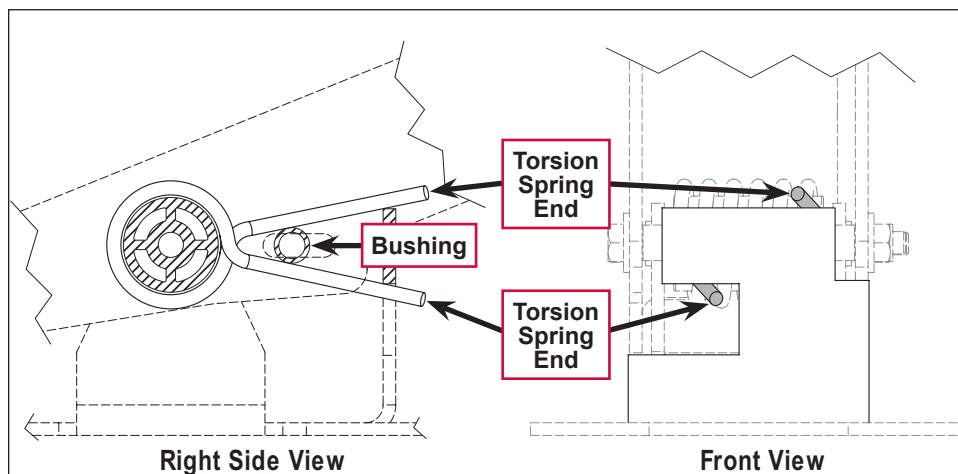

2. Place the **Bushing** inside the pedal channel. Pilot it into position using a scratch awl or a pin punch.
3. Pivot (press) the pedal and insert the screw from the opposite side, pushing the guide tool out.
4. Use a screwdriver to tap and pry the **Bushing** back in the pedal slot to increase spring tension.
5. Work the bushing back and forth on both sides of the pedal to obtain equal spacing, then tighten the screw and nut. A correctly-adjusted drive pedal will have minimal amount of free-play when selecting a drive direction.
6. Reconnect the batteries and test the machine to make sure it does not “creep” forward or reverse when the pedal returns to neutral.



Service Note: Also confirm that the Hourmeter/Status Display is free of the error code 03 (drive system fault). If error 03 is shown, the throttle is not set correctly for the potentiometer and/or drive pedal neutral position. Check both again and readjust.

Installation Checkout for the Curtis Speed Controller



Warning! The Curtis 1243 controller is inherently a high-power device. When working around any battery-powered vehicle, appropriate safety precautions must be taken. These include, but are not limited to: proper training, wearing eye protection, avoiding loose clothing and jewelry, and using insulated wrenches.

After installing a controller and before operating the vehicle, carefully complete the following checkout procedure. If you find a problem during the checkout, refer to the **Curtis Controller Diagnostics** section for further information.

The installation checkout can be conducted with or without the handheld programmer. The checkout procedure is easier with a programmer. Otherwise observe the status LED for codes (detergent system indicator). The part number of the handheld programmer is 56409441.



Warning! Put the vehicle up on blocks to get the drive wheel off the ground before beginning these tests.

Turn the key switch off and make sure that the throttle is in neutral.

Do not stand, or allow anyone else to stand, directly in front of or behind the vehicle during the tests.

1. Remove the electrical panel to access the controller then observe LED status light on the detergent system indicator light. If a programmer is available, connect it to the programmer plug-in port.
2. Turn the key switch on. The programmer should “power up” with an initial display. If neither happens, check for continuity in the key switch circuit and controller ground.
3. If you are using a programmer, put it into the diagnostic mode by pressing the **DIAGNOSTICS** key. The display should indicate **No Faults Found**.



Note: Before pressing the **DIAGNOSTICS** key, wait until the model # screen appears. If the throttle is activated prior to this screen appearing, the controller will shut down.

4. If there is a problem, the LED will flash a diagnostic code and the programmer will display a diagnostic message. If you are conducting the checkout without a programmer, look up the LED diagnostic code in the **Status LED Fault Codes** section.
5. When the problem has been corrected, it may be necessary to cycle the key switch to clear the fault code.
6. Move the drive pedal to operate the throttle. The motor should begin to turn in the selected direction. If it does not, check the wiring to the controller and to the motor. The motor should run proportionally faster with increasing throttle. If not, refer to the **Status LED Fault Codes** section.
7. If you are using a programmer, put it into the test mode by pressing the **TEST** key. Scroll down to observe the status of the forward, reverse and brake switch.
8. Cycle each switch in turn, observing the programmer. Each input should show the correct state on the programmer.
9. Take the vehicle off the blocks and drive it in an open area. It should have smooth acceleration and good top speed.

Specifications

General Specifications

Component	Specifications
Drive Motor Assembly	Type – 36 VDC, separately-excited (field and armature)
	Power – 1.75 HP (continuous)
	Gear Ratio – 32:1, double reduction
	Speed – 5.5 MPH
	Wheel Load – 2000 lbs.
	Lubrication – Mobiltemp 78 grease (in both cavities)

Wheel Drive Assembly Torque Specifications

Screw Size	Qty	Torque Value
5/16"-24	16	24-26 ft-lbs. [32-35 Nm]
1/4"-28	14	10 ft-lbs. [13 Nm]

A1 Speed Controller Pin Key Detail

Pin #	Wire Color	Controller Pin Description and Function
1	-	Open not used
2	ORN/RED	Fault 1: Controller fault output to operator control panel detergent LED status display.
3	YEL/RED	Rev direction/Back-up alarm. Auxiliary Driver output: Battery (+) commands, turns off solution, raises squeegee and sounds back-up alarm.
4	BLK/YEL	Main Contactor Driver: Battery (-) output to main contactor K7.
5	VIO/BLK	Throttle pot R1 Pot. High (+)
6	BRN/RED	Throttle pot R1 wiper input
7	WHT/BLK	Throttle pot R1 Pot. Low (-)
8	RED/WHT	Motion Auxiliary Driver: Battery (-) output signal to main controller (A2) to turn on (activate) all auto scrub functions.
9	BLK/WHT	Mode Select 2 input: Battery (+) (reference Speed Control Table) closed
10	-	Open not used
11	-	Open not used
12	-	Open not used
13	-	Open not used
14	BLU/BLK	Mode Select 1 input: Battery (+) (reference Speed Control Table) closed
15	GRN	Interlock: Seat switch (S2) input battery (+) to activate the main contactor driver pin 4 output to the K7 contactor. Note: With battery roll-out (option) the S3 interlock is wired in series with S2 and must also be closed.
16	ORN	KSI (key switch input): Battery (+) output powers up controller logic circuits.

A1 Speed Controller 16-Pin Connector Detail

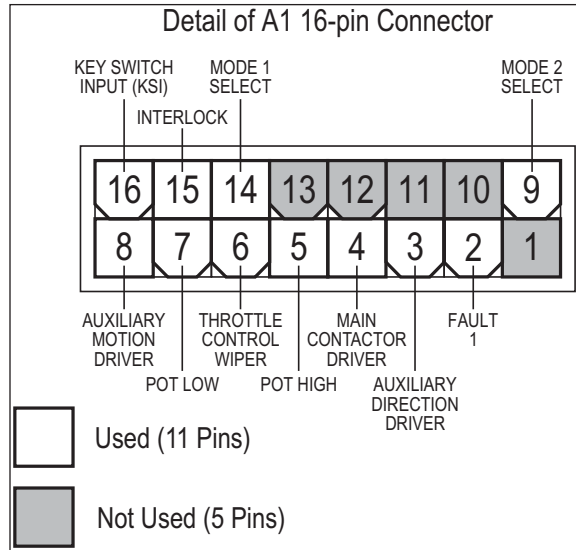

Speed Control Table

Pin 9 Select 2 (A2 Input)	Pin 14 Select 1 (A2 Input)	Effect
Low – 0V	Low – 0V	Transport Mode (Mode #1)
High – 36V	Low – 0V	Scrub Mode (Mode #2)
Low – 0V	High – 36V	Traction Mode (Mode #3)
High	High	N/A

Special Tools

<p>Curtis hand-held programmer, model 1311, part number 56409441</p>	
--	---

Appendix

Electrical Component Locations

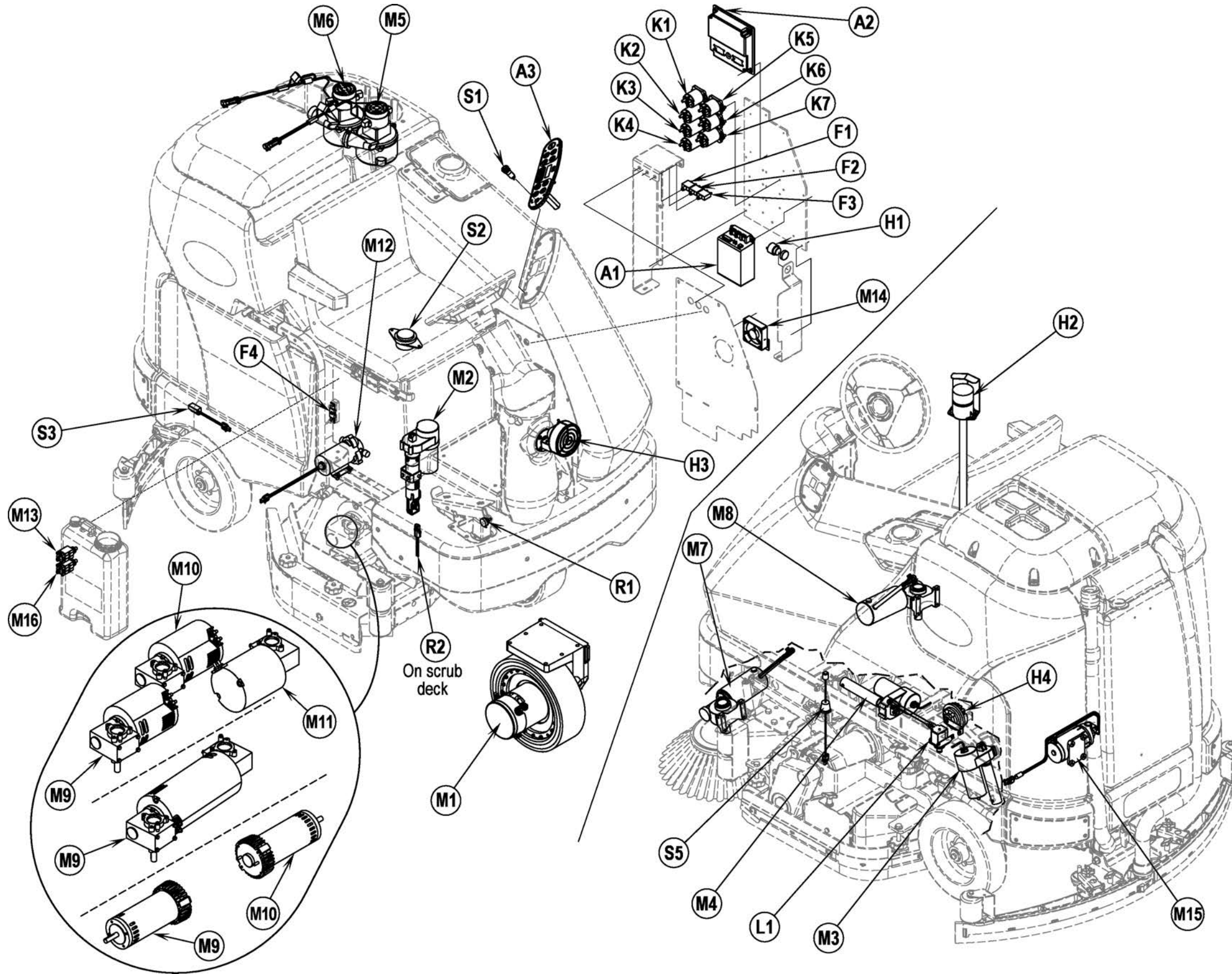

Item	Description
A1	Speed Control
A2	Control Board Assembly
A3	Switch/Display Panel Assembly
F1	Circuit Breaker, 3 Amp (Control Circuit)
F2	Circuit Breaker, 15 Amp (Auxiliary Circuit)
F3	Circuit Breaker, 20 Amp (Side Brooms)
F4	Fuse, 250 Amp
H1	Backup Alarm (optional)
H2	Strobe Light (optional)
H3	Headlight (optional)
H4	Horn
K1	Contactors, Vacuum
K2	Contactors, Right Brush (all models)
K3	Contactors, Center Brush (45"/48" disk and all cyl.)
K4	Contactors, Left Brush (45"/48" disk only)
K5	Contactors, Auxiliary
K6	Contactors, Side Brooms
K7	Contactors, Main (Speed Controller)
L1	Solenoid, Solution
M1	Motor, Wheel Drive
M2	Lift Actuator, Brush
M3	Lift Actuator, Squeegee
M4	Lift Actuator, Side Broom
M5	Motor Assembly, Vac.
M6	Motor Assembly, Vac. (optional)
M7	Gearmotor Assembly, Side Broom (cyl. models only)
M8	Gearmotor Assembly, Side Broom (cyl. models only).
M9	Motor, Gearbox Ass'y (disk) or Motor, Brush (cyl.)
M10	Motor, Gearbox Ass'y (disk) or Motor, Brush (cyl.)
M11	Motor, Gearbox Ass'y (disk) or Motor, Brush (cyl.)
M12	Pump, Solution Control (EcoFlex™)
M13	Pump, Chemical Metering (EcoFlex™)
M14	Fan Assembly
M15	Pump, Accessory (optional)
M16	Pump, Chemical Metering (EcoFlex™)
R1	Potentiometer, 5K Ohm (Throttle)
R2	Resistor Ass'y (Deck Type Selection)
S1	Switch, Key
S2	Switch, Seat
S3	Switch, Battery Interlock (optional)*
S5	Switch, Solution Empty

*Used with battery roll-out option.

Ladder Diagram, Rev. G

Item	Description
A1	Speed Control
A2	Control Board Assembly
A3	Switch/Display Panel Assembly
F1	Circuit Breaker, 3 Amp (Control Circuit)
F2	Circuit Breaker, 15 Amp (Auxiliary Circuit)
F3	Circuit Breaker, 20 Amp (Side Brooms)
F4	Fuse, 250 Amp
H1	Backup Alarm (optional)
H2	Strobe Light (optional)
H3	Headlight (optional)
H4	Horn
K1	Contactor, Vacuum
K2	Contactor, Right Brush (all models)
K3	Contactor, Center Brush (45"/48" disk and all cyl.)
K4	Contactor, Left Brush (45" / 48" disk only)
K5	Contactor, Auxiliary
K6	Contactor, Side Brooms
K7	Contactor, Main
L1	Solenoid, Solution
M1	Motor, Wheel Drive
M2	Lift Actuator, Brush
M3	Lift Actuator, Squeegee
M4	Lift Actuator, Side Broom
M5	Motor Assembly, Vac
M6	Motor Assembly, Vac (optional)
M7	Gearmotor Assembly (cyl. models only)
M8	Gearmotor Assembly (cyl. models only)
M9	Motor, Gearbox Ass'y (disk) or Motor, Brush (cyl.)
M10	Motor, Gearbox Ass'y (disk) or Motor, Brush (cyl.)
M11	Motor, Gearbox Ass'y (disk) or Motor, Brush (cyl.)
M12	Pump, Solution Control (EcoFlex™)
M13	Pump, Chemical Metering (EcoFlex™)
M14	Fan Assembly
M15	Pump, Accessory (optional)
M16	Pump, Chemical Metering (EcoFlex™)
R1	Potentiometer, 5K Ohm
R2	Resistor Ass'y
S1	Switch, Key
S2	Switch, Seat
S3	Switch, Battery Interlock (optional)*
S5	Switch, Solution Empty

*Used with battery roll-out option.

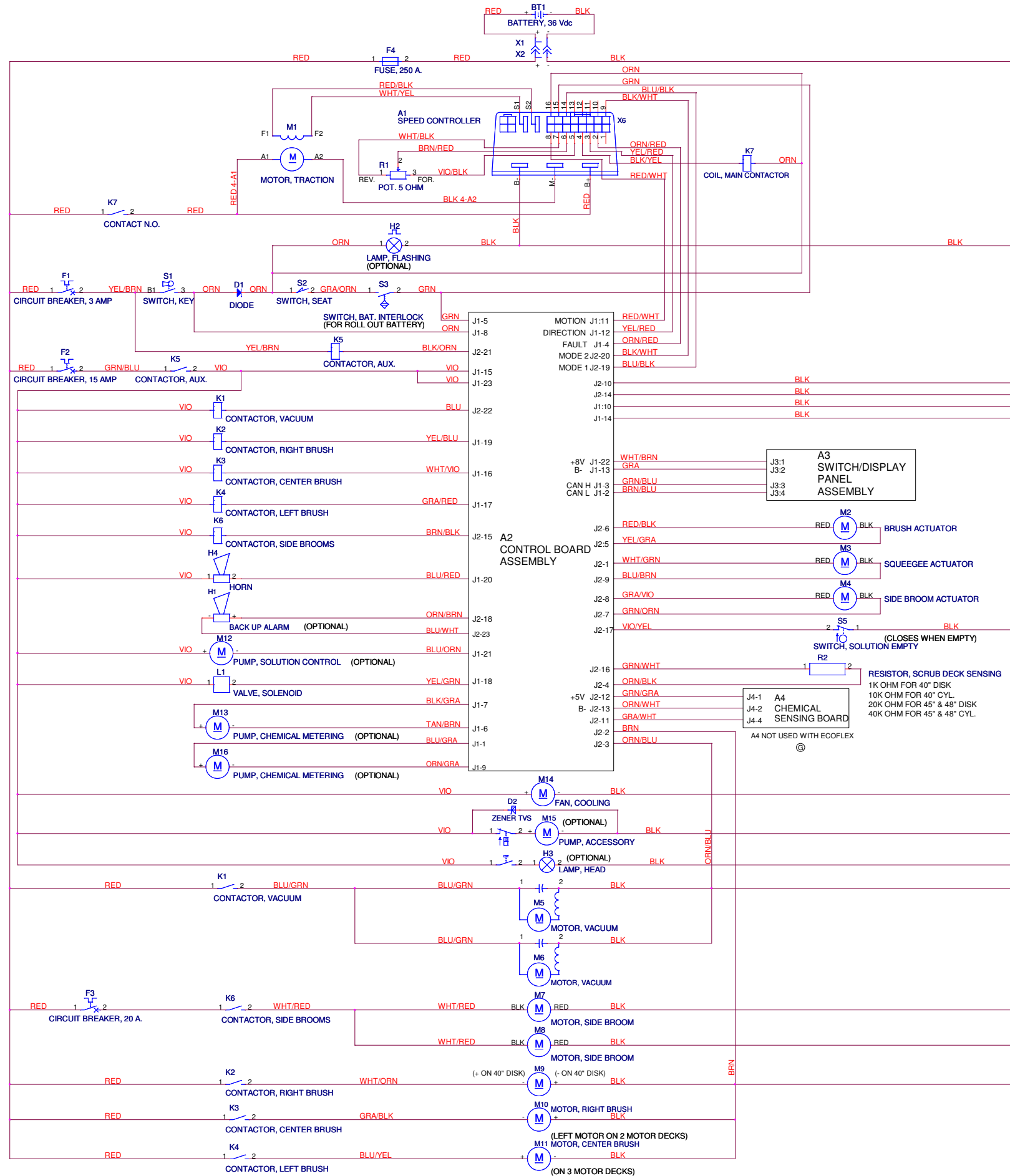

Wiring Diagram, Rev. I

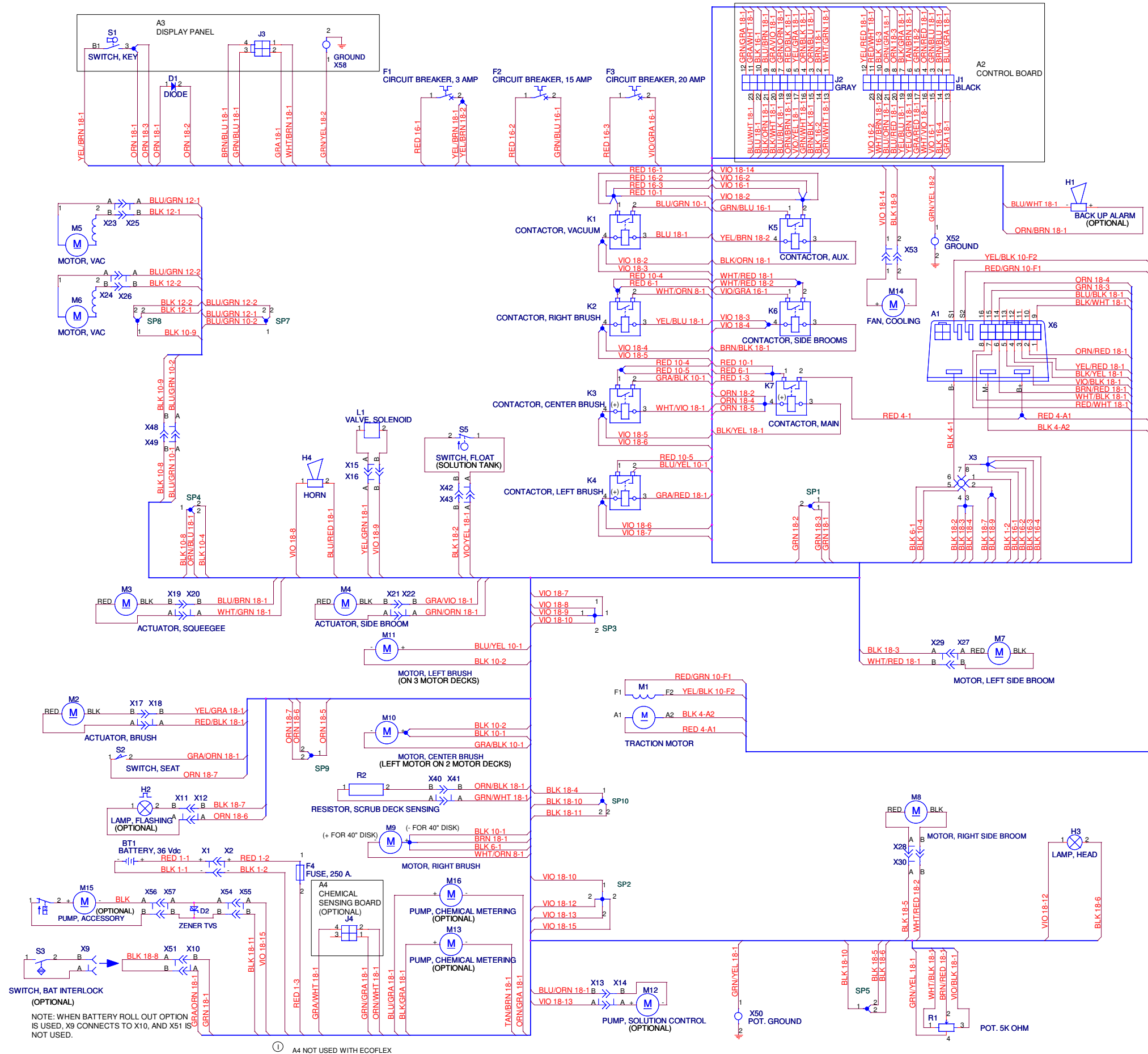

① A4 NOT USED WITH ECOFLEX

Detergent (EcoFlex™) System Plumbing Schematic

Item Description

- 1..... Solution Tank
- 2..... Shutoff Valve
- 3..... Inline Solution Filter
- 4..... Solution Pump
- 5..... Detergent Tank
- 6..... Detergent Pump (2)
- 7..... Drain Hose
- 8..... Drain Plug
- 9..... Solution Solenoid Valve
- 10..... Reducer Tee
- 11..... Y Barb, Fitting
- 12..... Solution Manifold (Disc Models)
- 13..... Tee
- 14..... Coupler Barb

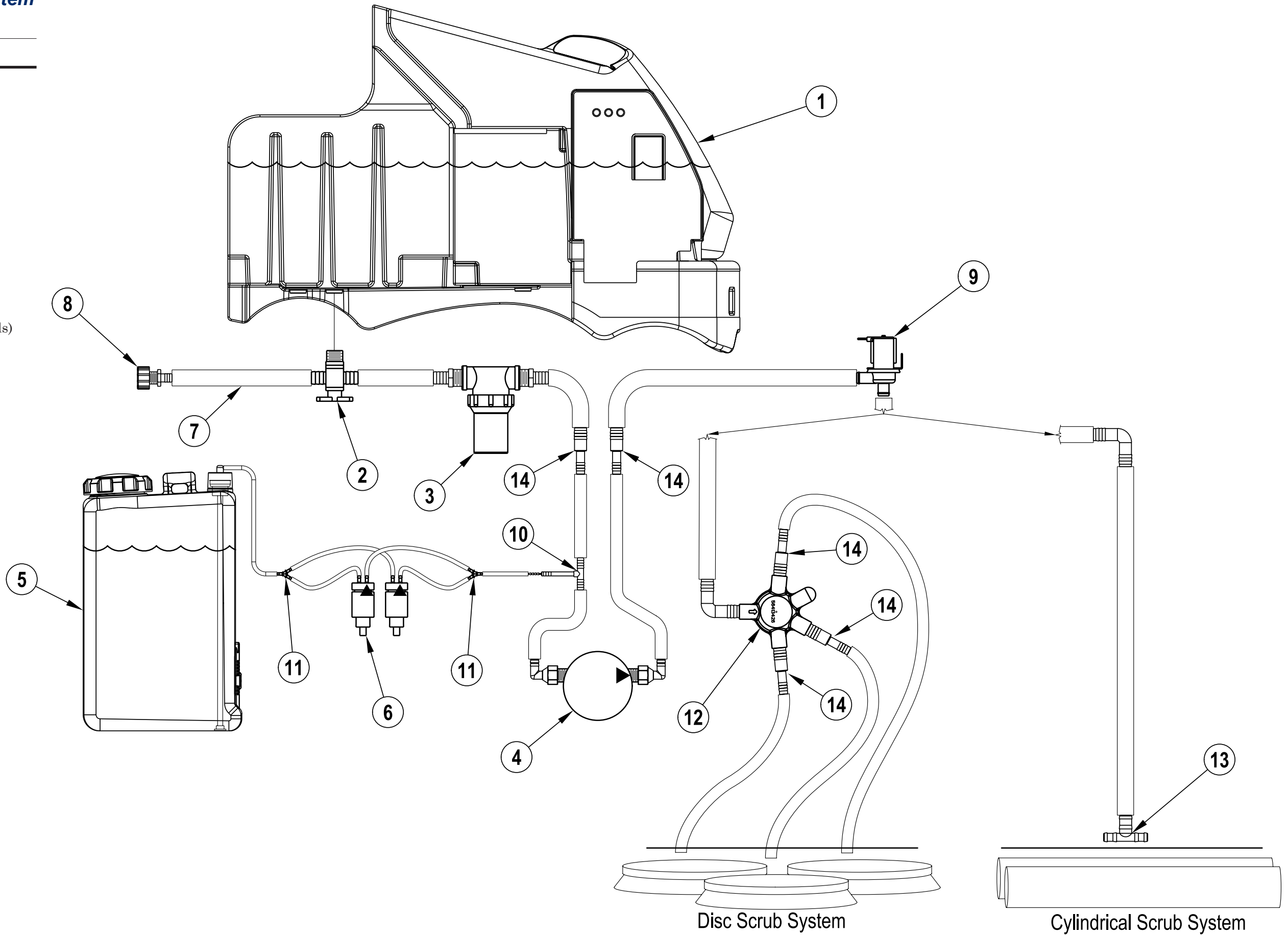

Disc Scrub System

Cylindrical Scrub System

Detergent (EcoFlex™) System Preparation and Purging

Preparations for Use

1. Fill the detergent cartridge with a maximum of 1.25 gallons [4.75 Liters] of detergent.



Service Note: Remove the detergent cartridge from the machine prior to filling to avoid spilling detergent on the machine.

It is recommended that a separate cartridge be used for each detergent you plan to use. The detergent cartridges have a white decal on them so you can write the detergent name on each cartridge to avoid mixing them up.

The system should be purged of previous detergent when switching to a different detergent. Move machine over floor drain before purging because a significant amount of detergent will be dispensed in the process.

2. Select the desired detergent ratio as follows:
 - a. Make sure the detergent system is switched off.
 - b. Press and hold the **Detergent Switch** for two seconds to enter the ratio programming mode. The **Detergent System Indicator** will blink while in the programming mode.
 - c. Press the **Detergent Switch** to cycle through the 10 available detergent ratios.
 - d. When the desired ratio is displayed, stop pressing the **Detergent Switch**. After five seconds the machine will lock in the displayed detergent ratio setting. (Also refer to the **Solution System/Maintenance and Adjustments/To Program the Detergent Ratio** section.)



Note: The detergent cartridge may have a magnetic slider on one end. On EcoFlex™ machines the magnetic slider has no effect on the detergent ratio and can be disregarded.

To Purge the Detergent System

1. Disconnect and remove the detergent tank.
2. Install and connect a tank filled with clean water.
3. Turn the key switch off.
4. Press and hold both the detergent and solution switches.
5. While holding the switches, turn the key switch on. The display will show the purge icon, the detergent and solution pumps will run for 20 seconds, then the pumps will shut off.
6. When the purge cycle is complete, turn the key switch off. Normally one purge cycle is adequate to purge the system.

To Purge the Detergent System When Changing Detergents

1. Disconnect and remove the detergent tank.
2. Turn the key switch off.
3. Press and hold both the detergent and solution switches.
4. While holding the switches, turn the key switch on. The display will show the purge icon, the detergent and solution pumps will run for 20 seconds, then the pumps will shut off.
5. When the purge cycle is complete, turn the key switch off.
6. Install and connect the new detergent tank.

