

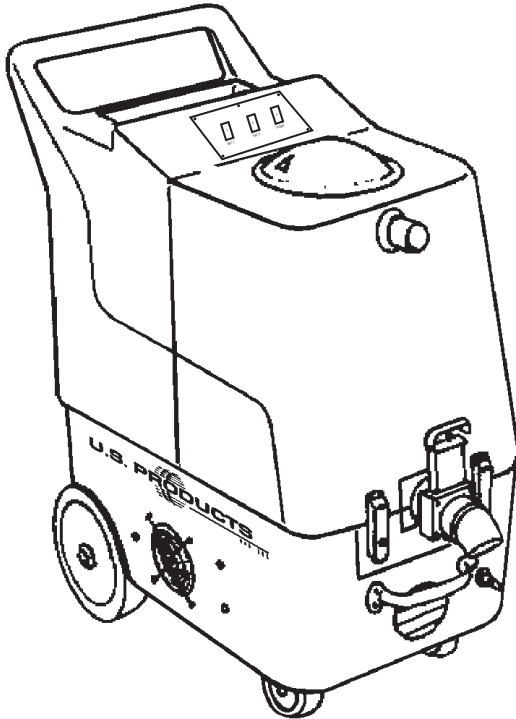

HP150-C EXTRACTOR 120V



INFORMATION & OPERATING INSTRUCTIONS

**DO NOT OPERATE MACHINE UNTIL YOU HAVE READ
ALL SECTIONS OF THIS INSTRUCTIONS**

IMPROPER USE OF THE MACHINE WILL VOID THE WARRANTY

1. Always use a defoamer when foaming occurs to prevent vacuum motor damage.
2. Keep machine from rain and snow, extremes in temperatures, and store in a heated location. Use the machine indoors. Do not use outdoors.
3. Do not let the pump run dry.
4. Use approved chemicals only. NO SOLVENTS.
5. Never use water above 130° F/54° C in the solution tank.

IMPORTANT SAFETY INSTRUCTIONS

This machine is only suitable for commercial use, for example in hotels, schools, hospitals, factories, shops and offices other than normal residential housekeeping purposes.

When using any electrical appliance, basic precautions should always be followed, including the following:

NOTE: Read all instructions before using this machine.

WARNING!

To reduce the risk of fire, electric shock, or injury:

- Do not leave the machine unattended when it is plugged in. Unplug the unit from the outlet when not in use and before servicing.
- To avoid electric shock, do not expose to rain or snow. Store, and use, indoors.
- Do not allow to be used as a toy. Close attention is necessary when used near children.
- Use only as described in this manual. Use only the manufacturer's recommended attachments.
- Never add water over 130° F/54° C to the solution tank.
- Do not use with damaged cord or plug. If the machine is not working as it should, has been dropped, damaged, left outdoors or dropped into water, return it to a service center.
- Do not pull by the cord, use the cord as a handle, close a door on the cord, or pull the cord around sharp edges or corners. Do not run the machine over the cord. Keep the cord away from heated surfaces. To unplug, grasp the plug, not the cord.
- Do not handle the plug, the cord, or the machine with wet hands.
- Extension cords must be 12/3 and no longer than 50 feet. Replace the cord or unplug immediately if the ground prong becomes damaged.
- Do not put any object into openings. Do not use with any opening blocked; keep free of dust, lint, hair, and anything that may reduce air flow.
- Keep loose clothing, hair, fingers, and all parts of body away from openings and moving parts.
- Do not pick up anything that is burning or smoking, such as cigarettes, matches, or hot ashes, or any health endangering dusts. Do not use to pick up flammable or combustible liquids such as gasoline or use in areas where they may be present.
- Turn off all controls before unplugging.
- Use extra care when cleaning on stairs.
- Connect to a properly grounded outlet only.
- Liquid ejected at the spray nozzle could be dangerous as a result of its temperature, pressure, or chemical content.

INSPECTION:

Carefully unpack and inspect your HP150-C for shipping damage. Each machine is tested and inspected before shipping. Any shipping damage incurred is the responsibility of the carrier. You should notify the carrier immediately if you notice damage to the box or to the machine or parts.

CLEANING SOLUTIONS:

We recommend liquid cleaning chemicals, such as our Magic Fabric Cleaner. Powder chemicals may be used, but unless mixed very thoroughly they could cause a build-up in the pump, lines, heat exchanger and/or quick disconnects. Any problem caused by a chemical build-up is not covered by warranty. Use a neutral cleaner with a pH between 6 and 9 to avoid premature wear of the pump, seals, and/or other components. Damage caused by the use of strong chemicals is not covered by the warranty.

MAINTENANCE:

For optimum performance flush the machine with clear water at the end of each working day. Once a month, minimum, run a flushing compound through the machine to break up any mineral or chemical build-up that may have formed. U.S. Products' "X-1500" is recommended. The vacuum motors, and the pump do not require any scheduled maintenance; however, the motors may require replacement brushes after 1000 - 1500 hours. Clean the body with an all-purpose detergent, and protect it with an automobile interior polish. Lubricate the wheels, castors, and quick disconnects with an all purpose silicone spray.

(and be sure to mail your warranty card)

Serial Number: _____

Model: HP150-C

Purchase Date: _____

Write the name and phone number of your distributor:

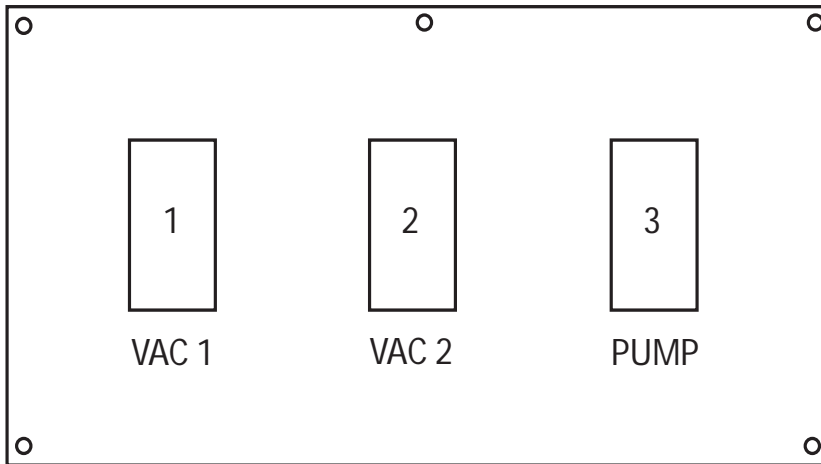

VACUUM SWITCH (1 & 2):

Each switch turns on one vacuum motor. Turn both switches on for maximum lift. The switches illuminate when turned on.

PUMP SWITCH (3):

This switch turns on the pump. The switch illuminates when turned on.

SET-UP:

Fill the holding tank with clear water and the detergent of your choice. Mix well.

1. Plug in cord . (This cord runs the pump and vacuums).
2. Turn on the pump and spray through the cleaning tool for a few seconds to fill the lines with solution.

BALL FLOAT VAC SHUTOFF:

When the recovery tank is full, the float system will shut off the incoming air flow and prevent water from entering the vacuum motors. The float may not work properly if the float ball cage is clogged or if there is foam in the tank. Foam may not lift the ball float.

CAUTION: To avoid vac motor damage, always make sure the float cage is clean and the ball travels freely before turning on the machine, and use a defoamer whenever foam is present.

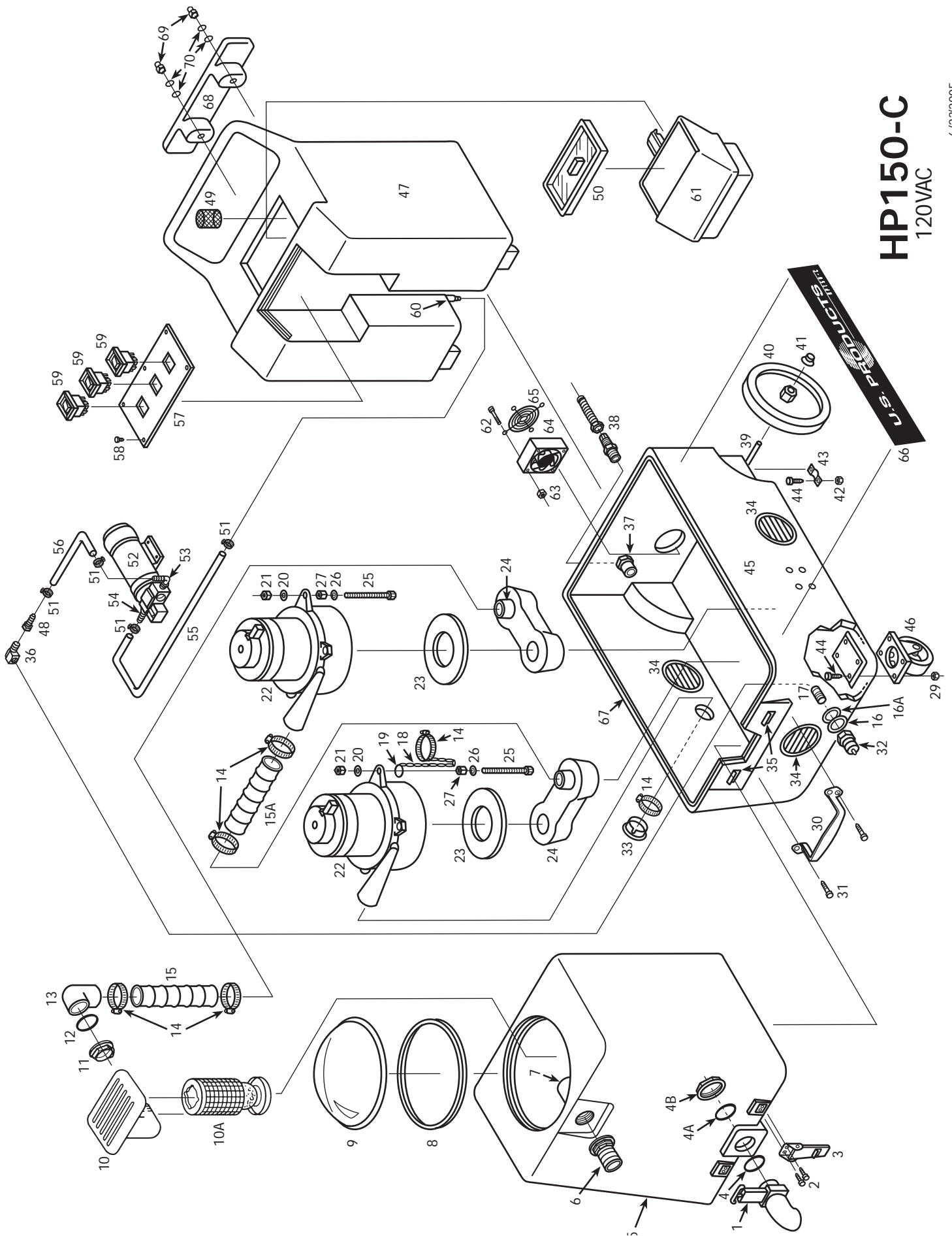

HP150-C

120VAC

6/23/2005

HP150-C 120V PARTS LIST

<u>ITEM #</u>	<u>PART #</u>	<u>DESCRIPTION</u>	<u>ITEM #</u>	<u>PART #</u>	<u>DESCRIPTION</u>
#1	903	Drain Gate (see Misc)*	#39	910	Axle, 1/2" X 17-1/2"
#2	21	Screw, Button Head, 10-32 x 5/8"	#40	2003	Wheel, 8"
#3	908	Latch	#41	27A	Axle Cap, Black
#4	187	O-Ring, Small	#42	8	Lock Nut, 1/4-20
#4A	190	O-Ring, Large	#43	180	Axle Bracket
#4B	185	Nut, 1-1/2"	#44	5	Bolt, 1/4-20 X 3/4"
#5	FP150-C	Vacuum Tank, HHP	#45	BBLK-1	Base, Black, HHP
#6	907	Hose Barb, 1-1/2"	#46	905	Castor, Swivel, 4"
#7	922	PVC Elbow, 1-1/2"	#47	T-1	Holding Tank, HHP
#8	2009	Gasket (Vacuum Dome)	#48	318AB	Hose Barb, 3/8" Hose x 1/4 p.t.
#9	FP201	Vacuum Dome	#49	207A	Filter, 40 Mesh, S/S
#10	FP193	Ball Float Assembly, Complete	#50	901	Lid, Holding Tank
#10A	924A	Float, Ball & Cage	#51	166	Hose Clamp
#11	185	Nut, 1-1/2"	#52	2066	Pump, 150 psi
#12	190	O-Ring, Large	#53	108A	Hose Barb, Plastic, 3/8 m.p.t.
#13	922	Elbow, PVC, 1-1/2"	#54	293	Hose Barb, Straight, 3/8" Hose x 3/8
#14	156	Hose Clamp (size 28)			p.t.
#15	FP171A	Hose, Vacuum Tank, 2" X 24"	#55	FP169C	Hose, Inlet, 3/8" X 11"
#15A	FP171B	Hose, Vacuum to Manifold 2" X 13"	#56	FP166	Hose, Outlet, 3/8" X 35"
#16	115	Washer, Fiber	#57	977	Switch Plate
#16A	31	Washer, Brass	#58	28	Screw, #4 x 3/8"
#17	92A	Nipple, Stainless Steel, 1/4 p.t.	#59	FP311	Switch, Pump, Vac Motors
#18	FP233B	Chain Assembly, 12"	#60	164	Hose Barb, 3/8" Hose x 1/4 p.t., Brass
#19	194	Split Ring	#61	FP204	Funnel, Black
#20	14	Washer, 3/16"	#62	2B1	Screw, 6-32 X 2"-1/4"
#21	8	Lock-Nut, 1/4-20	#63	16	Lock Nut, 6-32"
#22	FP324	Vacuum Motor, 2-Stage, w/Connectors	#64	2014	Fan, Cooling
#23	2013	Gasket (Vacuum Motor)	#65	2015	Guard, Fan
#24	MA-6	Manifold, Vacuum	#66	4333	Label
#25	270	Bolt, 1/4" x 5"	#67	FP228A	Gasket, Base
#26	14	Washer, 3/16"	#68	CWBLK	Cord Wrap, Black
#27	136	Nut, 1/4"	#69	260	Nut, Acorn, 3/8"
#29	8	Lock Nut, 1/4-20	#70	203	Washer, Nylon
#30	2010	Handle, Chrome			
#31	193	Screw, Flathead, 1/4-20 x 3/4"			
#32	45	Quick Disconnect, Male, 1/4 p.t.			
#33	FP220	Flange, Exhaust			
#34	928	Louver, 3" (includes screws)			
#35	909A	Latch Strike for Latch, S/S			
#36	91	Elbow, Brass			
#37	937	Reducer, PVC			
#38	184	Cord Retainer			
#38A	495A	Power Cord, Yellow, 25'			

MISCELLANEOUS ASSEMBLIES/PARTS

*FP231 Drain Gate Assembly Complete
includes Spout, O-Rings & Nut

(NOTE: Items in kits not sold separately.)

6-23-2005

TROUBLE SHOOTING:

IF THIS OCCURS

CHECK THIS

NO SPRAY	Solution tank is empty. Clogged spray tip. Pump not running. Valve on wand not operating
PUMP DOES NOT RUN	No power to pump. Test the switch. Test the pump motor
LOW SUCTION	Debris plugging cleaning tool or vacuum hose. Drain gate is not completely closed, or seals are damaged. Vacuum lid is loose or gasket is damaged.
NO SUCTION	No power to vacuum motor. Test the switch. Test the vacuum motor.

SPECIFICATIONS:

Rotomolded Body: Lifetime Warranty

Vacuum: Twin 2-stage 5.7" motors

VAC Shutoff: Ball float

Pump: Demand pump 150 psi

Waterlift: 150"

Wand: Stainless steel, single bend, twin tip

Weight: 82 lbs.

Dimensions: 26.5H x 18W x 28.75L (inches)

HP150-C EXTRACTOR 120V

NOTES:



208-772-0573 · 800-257-7982 · FAX: 208-772-0577

Coeur d'Alene, Idaho

VISIT US AT: <http://www.usproducts.com>