



# 3640

## *Power Sweeper*



**800.440.6723**

[www.southeasternequipment.net](http://www.southeasternequipment.net)

# 3640

**Power Sweeper**

# Simply Revolutionary



**Brush changes are fast and easy with no tools required.**



**Built-in vacuum wand cleans tight corners and hard-to-reach spaces.**

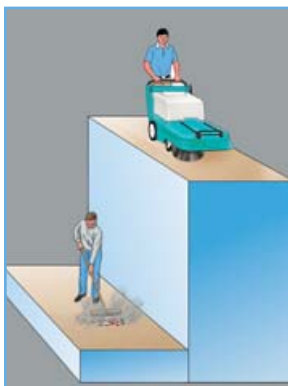

**The 3640 does one hour's hand sweeping in 10 minutes.**

A sweeper should be simple. Simple to use. Simple to maintain. Most of all, simple for operators to achieve maximum productivity, time after time.

This simplicity can be found in the Model 3640 power sweeper. The fewer parts in a sweeper, the fewer things can go wrong, and the easier it is to use and maintain. With the 3640, Tennant engineers created an award-winning, one-piece, rotationally molded frame that reduces hundreds of parts to just one.

On top of that, the hopper tips forward for easy emptying. All controls are within easy reach. Engine or batteries are easily accessible and brush changes require no tools or adjustment.

## **Productivity Enhancing Options**

A hopper dump assist handle tilts the hopper out of its cradle and rolls away for easy dumping. An optional panel filter system controls dust in filthy environments. Choose the dual side brushes for wider reach and greater productivity.



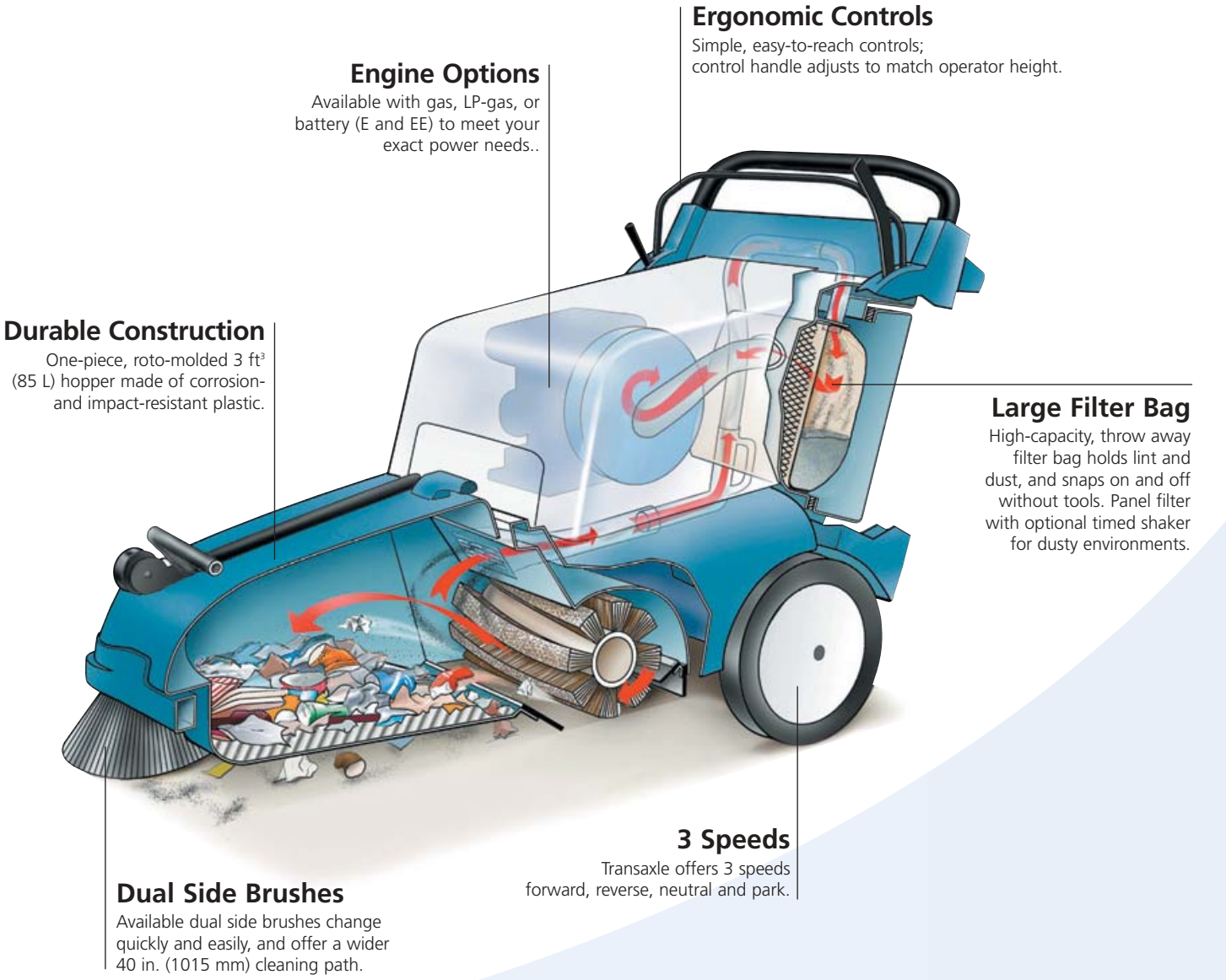

**Durable Construction**  
 One-piece, roto-molded 3 ft<sup>3</sup> (85 L) hopper made of corrosion- and impact-resistant plastic.

**Engine Options**  
 Available with gas, LP-gas, or battery (E and EE) to meet your exact power needs.

**Ergonomic Controls**  
 Simple, easy-to-reach controls; control handle adjusts to match operator height.

**Large Filter Bag**  
 High-capacity, throw away filter bag holds lint and dust, and snaps on and off without tools. Panel filter with optional timed shaker for dusty environments.

**Dual Side Brushes**  
 Available dual side brushes change quickly and easily, and offer a wider 40 in. (1015 mm) cleaning path.

**3 Speeds**  
 Transaxle offers 3 speeds forward, reverse, neutral and park.



Rugged, durable and compact to clean a variety of environments.



Sweeps carpet, tennis courts, and many indoor areas including office environments.



An optional outdoor package comes with wide pneumatic tires and larger front casters.

# 3640 POWER SWEEPER SPECIFICATIONS

## MACHINE DIMENSIONS

Length	56.25 in	1430 mm
Width	32.25 in	820 mm
Height	37.7 in	960 mm

## CLEANING SYSTEM

Cleaning path (single side brush)	32 in	810 mm
Cleaning path (dual side brush)	40 in	1015 mm
Hopper volume capacity	3 ft <sup>3</sup>	85 L
Hopper weight capacity	130 lb	59 kg
Vacuum fan	9 in	230 mm
Main brush length	24 in	610 mm
Side brush diameter	16.5 in	420 mm
Filter bag capacity	1050 in <sup>3</sup>	17.2 L

## POWER PLANTS

Air cooled gasoline/LP (max)	6.0 hp	4.48 kW
Battery power (propelling motor)	1.0 hp	0.75 kW

## PROPELLING SYSTEM

3 speeds forward (variable)	3.3 mph	5.3 km/h
Speed reverse (variable)	1.4 mph	2.25 km/h

## GRADEABILITY

Full hopper	8.0 deg	14.1%
Empty hopper	8.0 deg	14.1%

## TENNANT VALUE ADDED EQUIPMENT INCLUDES:

Fully variable forward/reverse speed, brush compartment recirculation, control with park position wrap, adjustable height propelling control, key switch handle, free-floating hopper, smart charger, low engine oil level indicator light, no-tool brush change

## TO CUSTOMIZE, HERE ARE YOUR OPTIONS:

Live vacuum wand, carpet sweeping configuration, extended run-time battery package, outdoor package, hopper dump assist, panel filter with timed shaker, battery disconnect control button, dual side brushes

## Dimensions

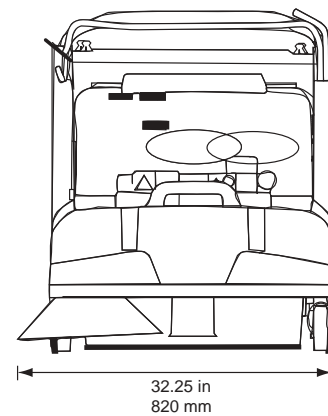
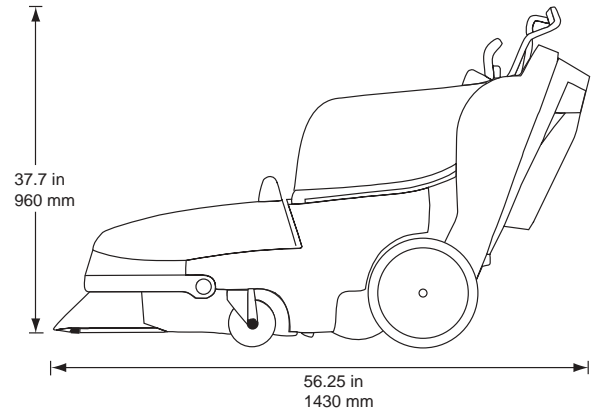

ISO 9001 Certified Specifications are subject to change without notice

## Creating a cleaner, safer world™

Tennant Company offers the most complete lines of floor and surface maintenance equipment, floor coatings, brushes and cleaning detergents in the world, for the industrial, commercial and outdoor cleaning markets. Our sales and service networks are able to provide you with integrated custom cleaning solutions to meet any floor care need.



### Tennant Company

701 North Lilac Drive, Minneapolis, MN 55440, USA  
 Mailing Address: P.O. Box 1452, Minneapolis, MN 55440, U.S.A.  
 Tel: (763) 540-1200, Toll-free: (800) 553-8033  
 Fax: (763) 513-2144, In Quebec, call: (514) 335-6061

### Commercial Products

12875 Ransom Street, Holland, MI 49424, USA  
 Tel: (616) 786-2330, Toll-free: (800) 982-7658  
 Fax: (800) 678-4240, E-mail: [tcoinfo@tennantco.com](mailto:tcoinfo@tennantco.com)  
 Web Address: [www.tennantco.com](http://www.tennantco.com)

Authorized Tennant Sales Representative

**Southeastern**  
EQUIPMENT & SUPPLY, INC.

**800.440.6723**

[www.southeasternequipment.net](http://www.southeasternequipment.net)